

Xorcom UC42 User Manual

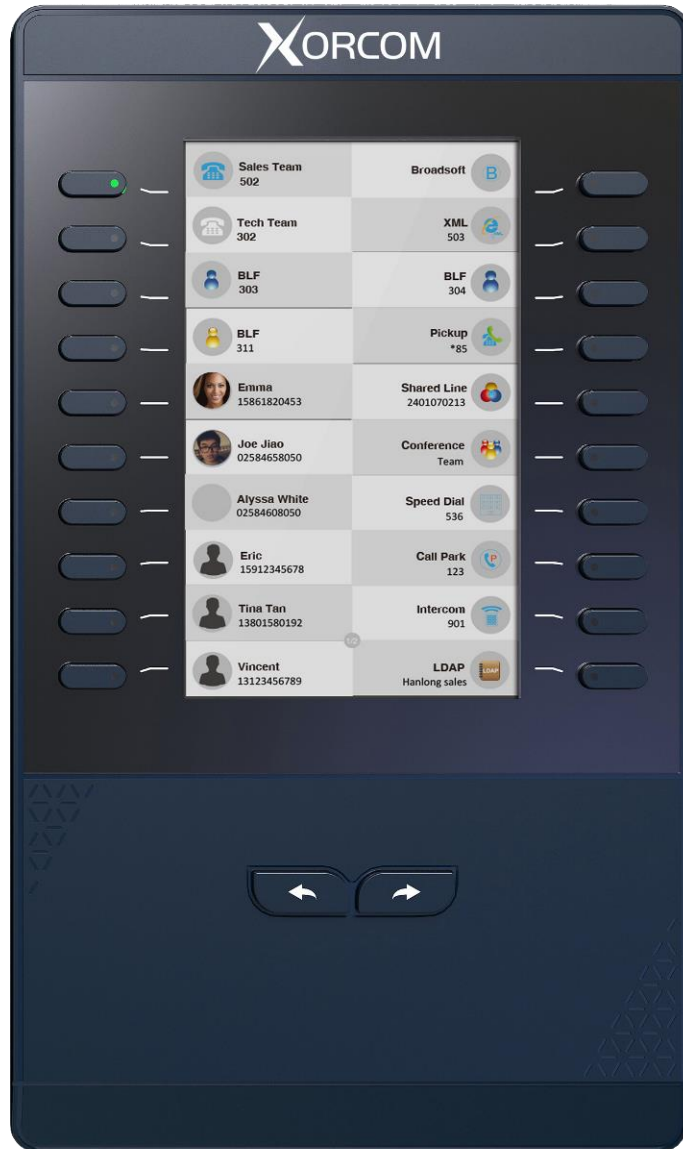

Information

Safety Instructions

- To use the expansion module, please follow the instructions in this user manual.
- Use the power adapter supplied with your expansion module. Other power adapters may damage the expansion module.
- This expansion module is only for indoor use. And also avoid in high humidity, water and some other liquids.
- Do not use the expansion module during thunderstorms.
- CE
- FCC

WEEE Warning



To avoid the potential effects on the environment and human health as a result of the presence of hazardous substances in electrical and electronic equipment, end users of electrical and electronic equipment should understand the meaning of the crossed-out wheeled bin symbol. Do not dispose of WEEE as unsorted municipal waste and have to collect such WEEE separately.

Cleaning

To clean the device, use an anti-static cloth. Please avoid cleaning liquids as they might damage the surface or internal electronics of the expansion module.

FCC Statement

1. This device complies with Part 15 of the FCC Rules. Operation is subject to the following two conditions:

- (1) This device may not cause harmful interference.
- (2) This device must accept any interference received, including interference that may cause undesired operation.

2. Changes or modifications not expressly approved by the party responsible for compliance could void the user's authority to operate the equipment.

NOTE: This equipment has been tested and found to comply with the limits for a Class B digital device, pursuant to Part 15 of the FCC Rules. These limits are designed to provide reasonable protection against harmful interference in a residential installation.

This equipment generates uses and can radiate radio frequency energy and, if not installed and used in accordance with the instructions, may cause harmful interference to

radio communications. However, there is no guarantee that interference will not occur in a particular installation. If this equipment does cause harmful interference to radio or television reception, which can be determined by turning the equipment off and on, the user is encouraged to try to correct the interference by one or more of the following measures:

- Reorient or relocate the receiving antenna.

- Increase the separation between the equipment and receiver.

- Connect the equipment into an outlet on a circuit different from that to which the receiver is connected.

- Consult the dealer or an experienced radio/TV technician for help.

Table of Content

Xorcom UC42 User Manual.....	1
Information	2
Safety Instructions	2
WEEE Warning.....	2
Cleaning.....	2
FCC Statement.....	2
Table of Content.....	4
Getting Started.....	6
Packing List	6
Expansion Module Installation.....	8
1. Connect the expansion module and IP Phone	8
2. Attach the Foot stand	9
3. Connect the IP Phone and Power.....	9
Getting Familiar with Expansion Module	10
Hardware Components Preview.....	10
Icon Preview	11
Features Configuration	13
Screen Saver.....	13
Line	13
Speed Dial	14
BLF	15
BLF List.....	16
Voice Message	17
Direct Pickup.....	17
Group Pickup	18
Call Park	18
Intercom.....	19
DTMF	20
Prefix.....	21
Local Group	21
XML Group.....	22
LDAP	22
Network Directories	23
Conference	23
Forward.....	24
Transfer.....	24
Hold.....	25
Group Listening	25
DND	25
Redial.....	26
Call Return.....	26
SMS	27

Record	27
URL Record	28
Paging.....	28
Public Hold.....	29
Private Hold	29
Hot Desking	30
ACD	30
Zero Touch.....	31
URL.....	31
MultiCast Paging	31
Upgrade	32
IP Phone upgrades the expansion module FW.....	32
Expansion module gets the fw46M.rom from IP Phone.....	33

Getting Started

Packing List

The package contains the following parts, please check if all the items are not missed:

1. The Expansion module device

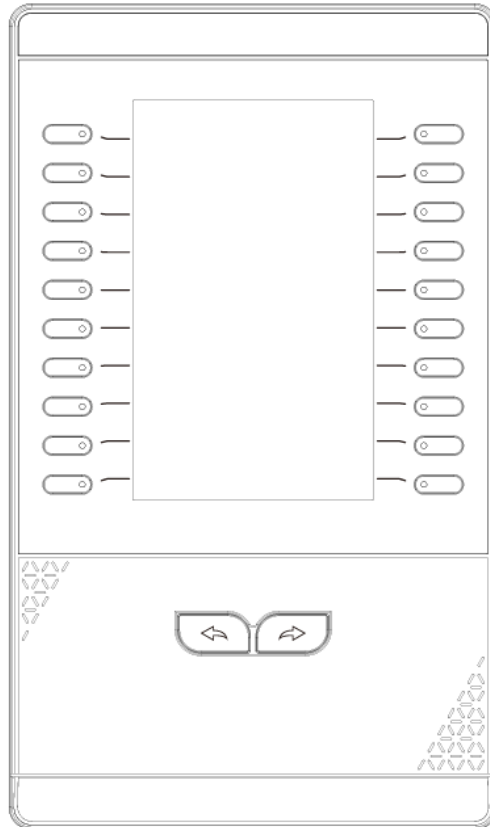

2. The Stand

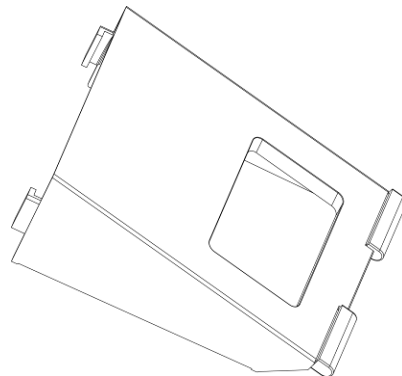

3. Connecting Sheet

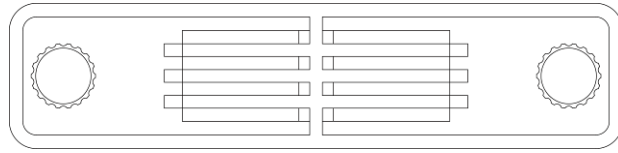

4. Power adapter

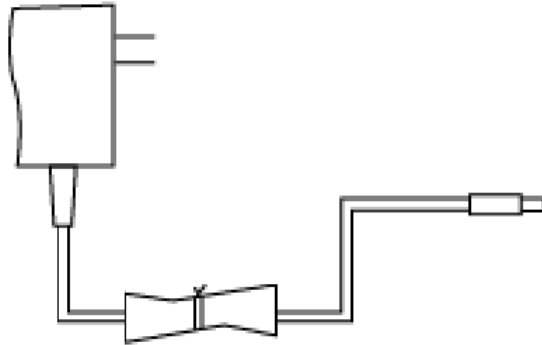

5. Ethernet cable/Connecting Cord

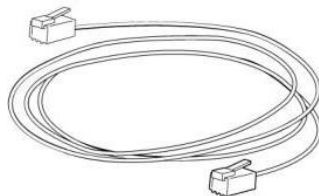

6. Screws

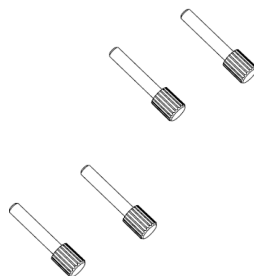

7. Quick installation reference

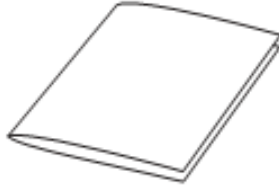

Expansion Module Installation

1. Connect the expansion module and IP Phone

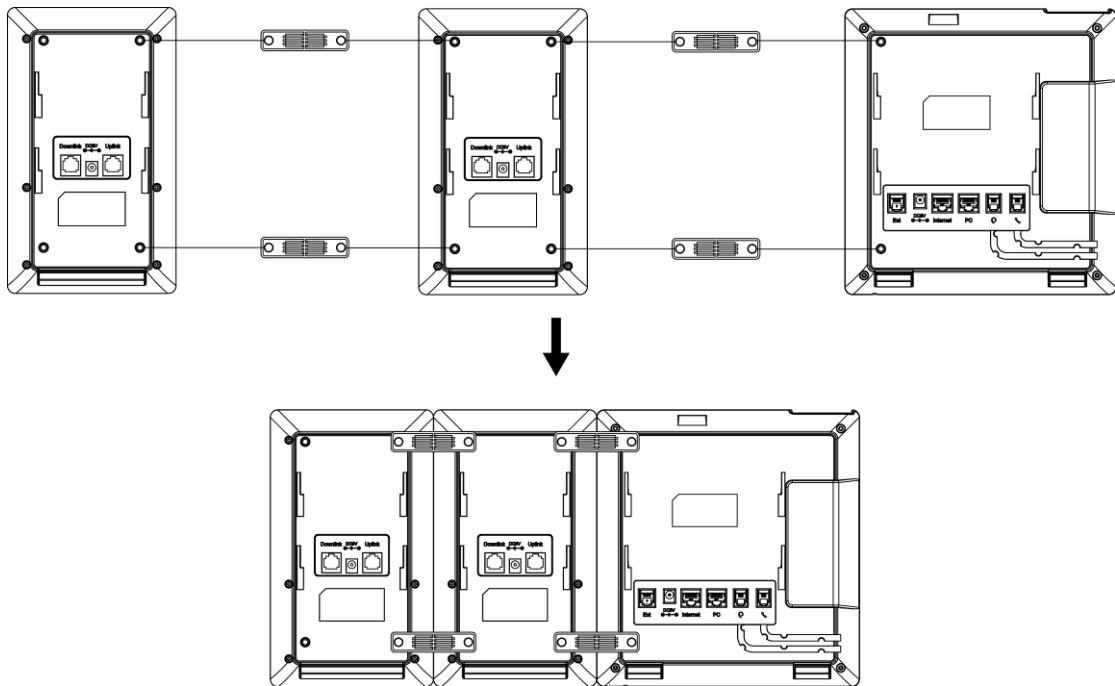

2. Attach the Foot stand

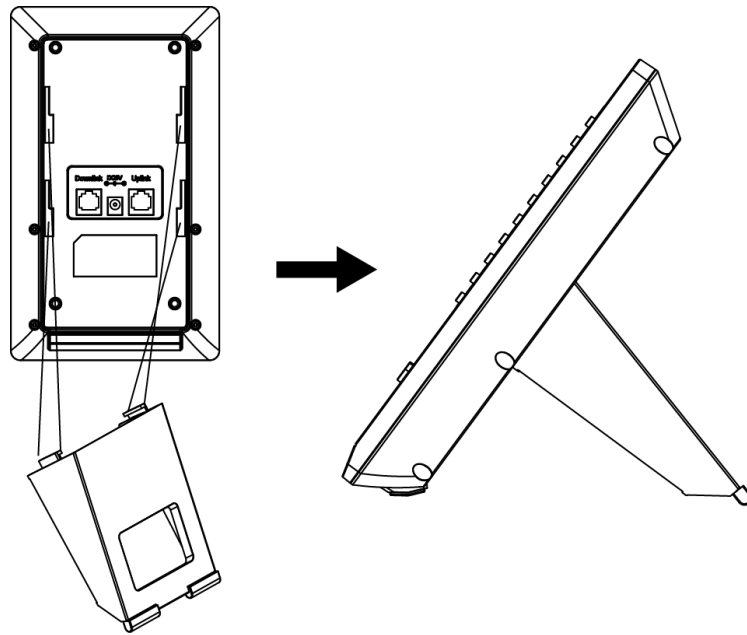

3. Connect the IP Phone and Power

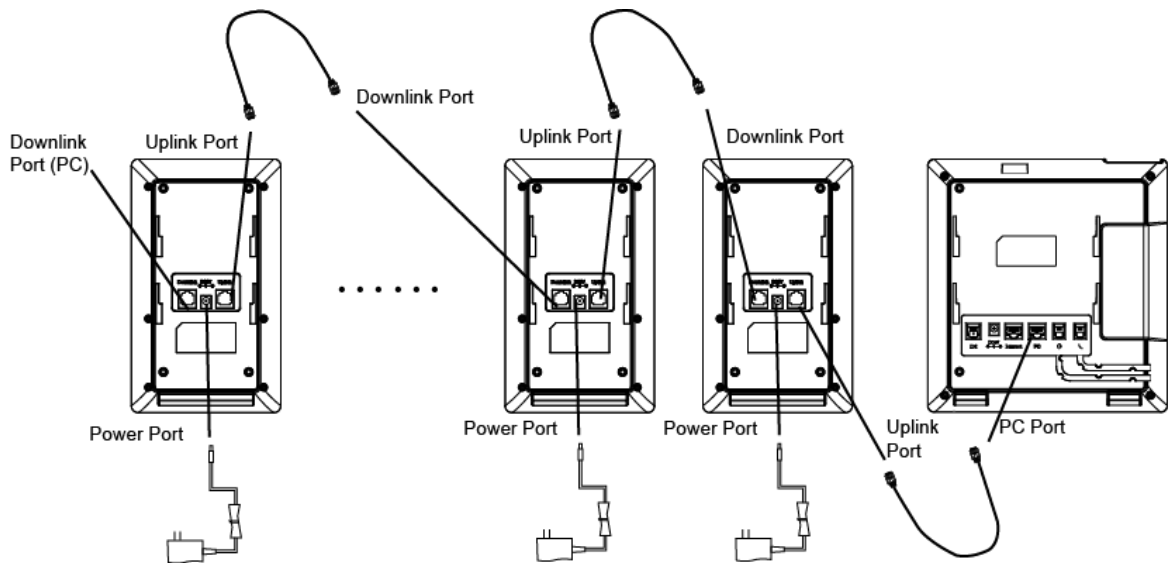

Note:

1. In order to use the UC42, you must first change a setting in the phone attached to the UC42 to accept Expansion Modules on the PC Port. This setting can be found in the phone menu under "Settings / Advanced Settings / Network / PC Port " or in the web GUI under "Network / PC Port / Connect to Expansion Module".
2. Expansion modules must be connected to the IP Phone's PC port and can't be connected to the any switches in a LAN.
3. IP phone can support six expansion modules at most.

Getting Familiar with Expansion Module

Hardware Components Preview

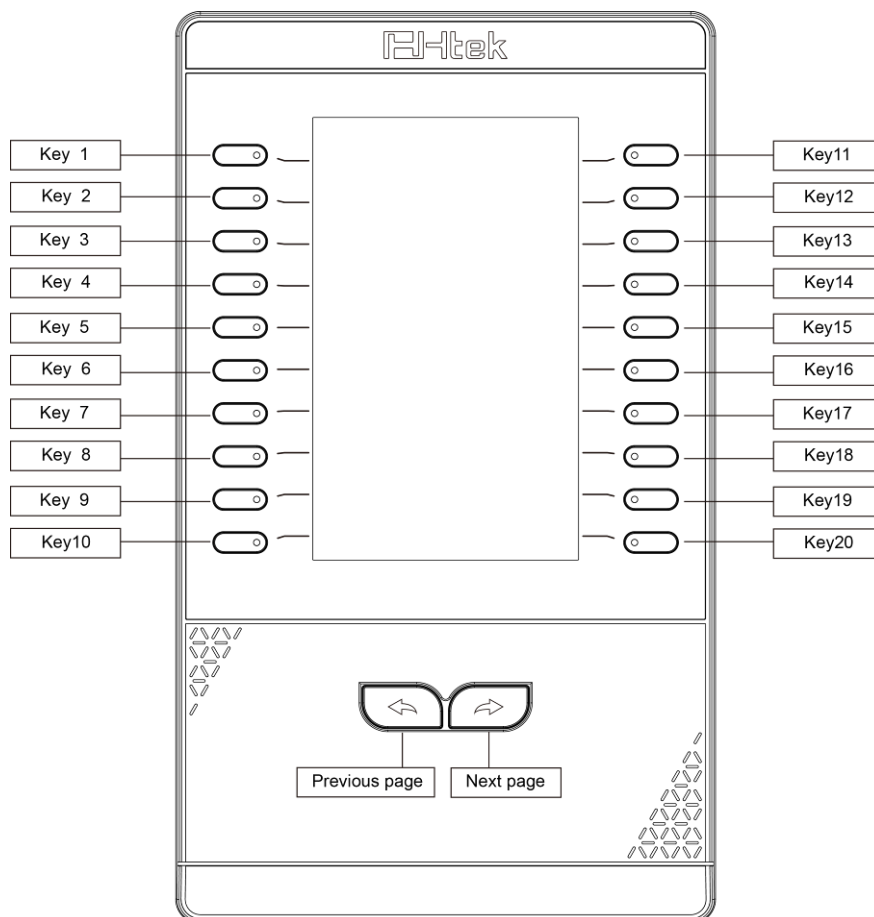

Icon Preview

Icon	Description
	Line(Registered succeed)
	Line (Unregistered)
	Line(Ringing)
	Speed Dial
	BLF
	BLF(Ringing)
	BLF(Talking)
	Voice messages
	Pick up
	Call Park
	Intercom/Paging
	DTMF
	Prefix
	XML Group
	Local Group

	XML Browser
	LDAP
	Network Directories
	Conference
	Forward
	Transfer
	Hold
	Line on Hold
	DND
	Redial
	Call Return
	SMS
	Record
	Recording
	Group Listening
	Shared Line
	Other Functions

Features Configuration

Screen Saver

It supports a screen saver.

To configure screen saver via Web Interface:

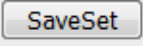
1. Click Setting → Preference.
2. Fill in the time for Expansion screensaver time.
3. Click the  to save the configuration.

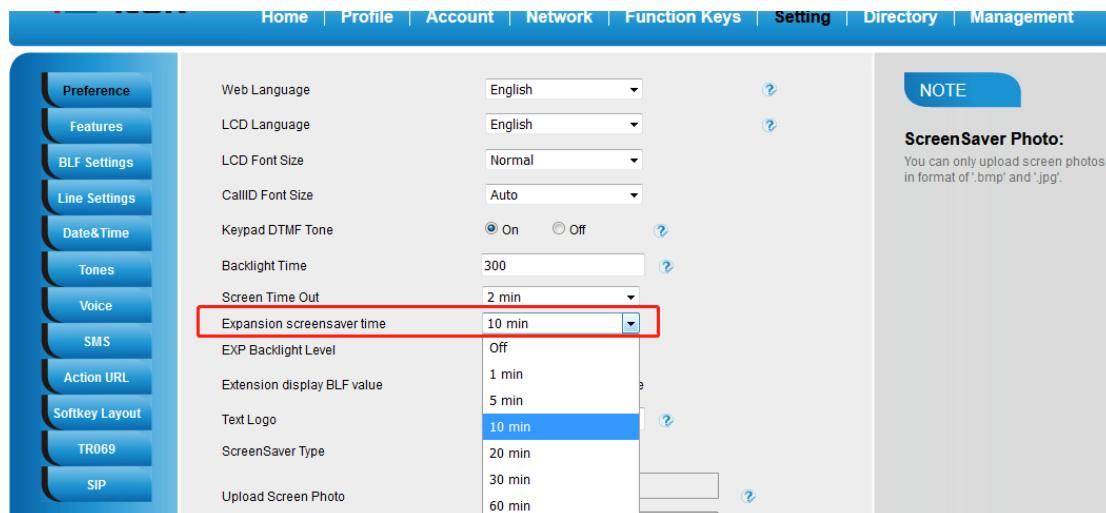

Line

It works same as Line keys.

Line support three Mode (Default, lock and float)

Default mode: If the phone has a incoming call, it means that the phone will not jump to the first page when the first page set the line type and current page is four page.

Lock mode: it means that the other page's same position has the same line when the first page set the line type.

Float mode: If the phone has a incoming call, it means that the phone will jump to the first

page when the first page set the line type and current page is four page.

To configure Line Feature via Web Interface

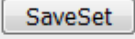
1. Click Function keys →EXP Key.
2. Select the wanted Key and set as Line.
3. Select the Account.
4. Click the  to save the configuration.

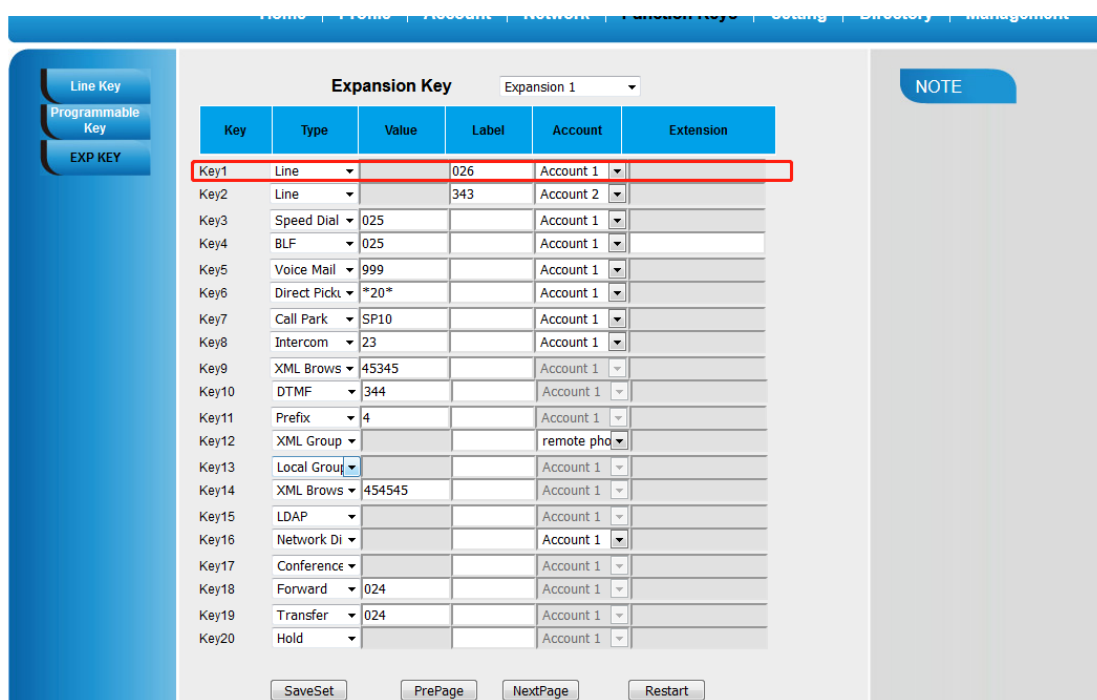

Speed Dial

With this feature, you can dial one directory by press the definite key.

To configure Speed Dial feature via Web Interface

1. Click Function keys →EXP Key.
2. Select the wanted Key and set as Speed Dial.
3. Enter the desired phone number in the Value field.
4. Fill in the Label displayed on LCD
5. Select the Account.

- Click the  to save the configuration.

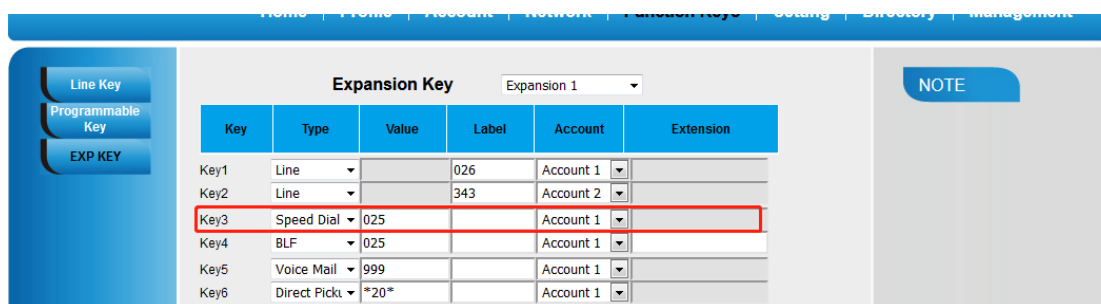

Key	Type	Value	Label	Account	Extension
Key1	Line		026	Account 1	
Key2	Line		343	Account 2	
Key3	Speed Dial	025		Account 1	
Key4	BLF	025		Account 1	
Key5	Voice Mail	999		Account 1	
Key6	Direct Pickt	*20*		Account 1	

BLF

You can use the BLF (Busy Lamp Field) feature to monitor a specific one whether his phone is busy or free.

- When the monitored line is idle, the light is steady green.
- When the monitored line is ringing, the light is blinking red, press the BLF key to pick the phone up directly.
- When the monitored line is calling or in a conversation, the light is steady red.

To configure a BLF key by web

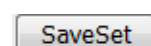
- Click Function keys → EXP Key.
- Select the desired Key and select BLF in the Type.
- Enter the monitored phone number in the Value field.
- Fill in the Label displayed on LCD.
- Select the Account.
- Fill in the Pickup code.
- Click the  to save the configuration.

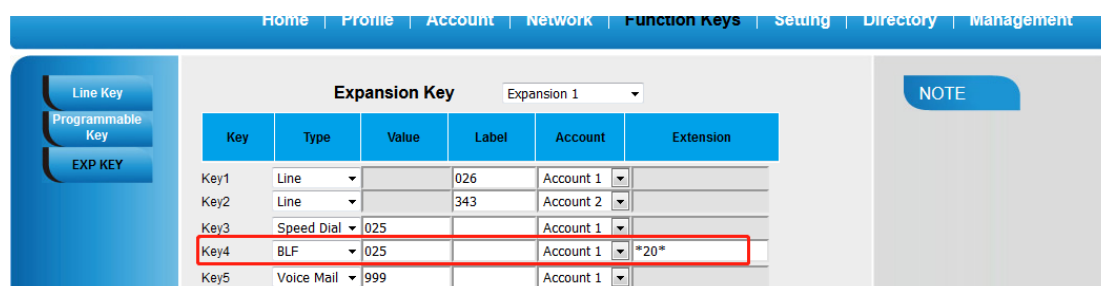

Key	Type	Value	Label	Account	Extension
Key1	Line		026	Account 1	
Key2	Line		343	Account 2	
Key3	Speed Dial	025		Account 1	
Key4	BLF	025		Account 1	*20*
Key5	Voice Mail	999		Account 1	

Note:

This feature is not available on all servers. For more information, contact your system administrator.

After setting the BLF key, do not need to restart the phone.

BLF List

To configure BLF List via web interface:

1. Login and click Account->Basic ,then fill in the Eventlist BLF URL.

The screenshot shows the 'Basic' configuration page for an account. The 'Eventlist BLF URL' field is highlighted with a red box and contains the value 'blf_sales'. Other fields include Account Status, Account Active, Profile, Label, SIP User ID, Authenticate ID, Authenticate Password, Name, Local SIP Port, Use Random Port, Voice Mail UserID, Dial Plan, Shared Line, SCA Barge-In, Direct Call Pickup Code, Group Call Pickup Code, and Feature Key Sync.

3. To configure BLF List Keys

3.1 Click Function keys → EXP Key.

3.2 Select the BLF List in the Type Field.

3.3. Select Account.

3.4 Click to **SaveSet** the configuration.

The screenshot shows the 'Expansion Key' configuration page. The 'Key5' row is highlighted with a red box, showing 'BLF List' as the Type and 'Account 1' as the Account. Other keys are listed with their respective types and values.

Key	Type	Value	Label	Account	Extension
Key1	Line		026	Account 1	
Key2	Line		343	Account 2	
Key3	Speed Dial	025		Account 1	
Key4	BLF	025		Account 1	
Key5	BLF List			Account 1	

Voice Message

To configure Voice Mail feature via Web Interface

1. Click Function keys → EXP Key.
2. Select the wanted Key.
3. Enter the desired voicemail feature codes in the Value field.
4. Fill in the Label displayed on LCD.
5. Select the Account.
6. Click the to save the configuration.

Home | Profile | Account | Network | **Function Keys** | Setting | Directory | Management

Line Key
Programmable Key
EXP KEY

Expansion Key Expansion 1

Key	Type	Value	Label	Account	Extension
Key1	Line		026	Account 1	
Key2	Line		343	Account 2	
Key3	Speed Dial	025		Account 1	
Key4	BLF	025		Account 1	
Key5	Voice Mail	999		Account 1	

NOTE

Direct Pickup

With this feature, you can pick up the set line when it ringing.

To configure Direct Pickup feature via Web Interface

1. Click Function keys → EXP Key..
2. Select the wanted Key and set as Direct Pickup.
3. Enter the pickup code and followed the desired phone number in the Value field.
4. Fill in the Label displayed on LCD.
5. Select the Account.
6. Click the to save the configuration.

Home | Profile | Account | Network | **Function Keys** | Setting | Directory | Management

Line Key
Programmable Key
EXP KEY

Expansion Key Expansion 1

Key	Type	Value	Label	Account	Extension
Key1	Line		026	Account 1	
Key2	Line		343	Account 2	
Key3	Speed Dial	025		Account 1	
Key4	BLF	025		Account 1	
Key5	Voice Mail	999		Account 1	
Key6	Direct Pickt	*20*		Account 1	
Key7	Call Park	SP10		Account 1	
Key8	Intercom	23		Account 1	

NOTE

Group Pickup

With this feature, you can pick up the specified group that you want incoming calls.

To configure the Group Pick up via Web interface

1. Click Function keys → EXP Key.
2. Select the desired Key and select Group Pickup in the Type.
3. Enter the pickup code and followed the desired Group number in the Value field.
4. Fill in the Label displayed on LCD..
5. Click the  to save the configuration.

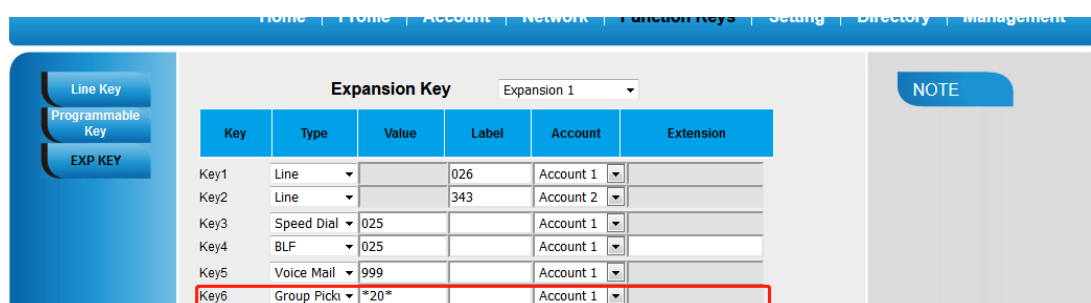

Expansion Key Expansion 1

Key	Type	Value	Label	Account	Extension
Key1	Line		026	Account 1	
Key2	Line		343	Account 2	
Key3	Speed Dial	025		Account 1	
Key4	BLF	025		Account 1	
Key5	Voice Mail	999		Account 1	
Key6	Group Pickup	*20*		Account 1	

Call Park

With this feature, you can put a call on hold and continue the conversation from another phone.

To configure the Call Park via Web interface

1. Click Function key → EXP Key.
2. Select the desired Key and select Call Park in the Type.
3. Enter the park feature codes in the value field.
4. Fill in the Label displayed on LCD.
5. Select the Account.
6. Click the  to save the configuration.

Home | Profile | Account | Network | **Function Keys** | Setting | Directory | Management

Line Key
Programmable Key
EXP KEY

Expansion Key Expansion 1

Key	Type	Value	Label	Account	Extension
Key1	Line		026	Account 1	
Key2	Line		343	Account 2	
Key3	Speed Dial	025		Account 1	
Key4	BLF	025		Account 1	
Key5	Voice Mail	999		Account 1	
Key6	Group Pick	*20*		Account 1	
Key7	Call Park	SP10		Account 1	
Key8	Intercom	23		Account 1	

NOTE

Note:

Your VoIP PBX must support this feature and enable this feature.

Intercom

When use the intercom feature, you can quickly get access connect to the configured Expansion.

To configure Intercom feature via Web Interface

1. Click Function keys → EXP Key.
2. Select the wanted Key and select Intercom as the Type.
3. Enter the intercom codes followed by desired number in the Value field.
4. Fill in the Label displayed on LCD.
5. Select the Account.
6. Click the **SaveSet** to save the configuration.

Home | Profile | Account | Network | **Function Keys** | Setting | Directory | Management

Line Key
Programmable Key
EXP KEY

Expansion Key Expansion 1

Key	Type	Value	Label	Account	Extension
Key1	Line		026	Account 1	
Key2	Line		343	Account 2	
Key3	Speed Dial	025		Account 1	
Key4	BLF	025		Account 1	
Key5	Voice Mail	999		Account 1	
Key6	Group Pick	*20*		Account 1	
Key7	Call Park	SP10		Account 1	
Key8	Intercom	23		Account 1	

NOTE

If you want to achieve the intercom feature, you must enable the “Allow Auto Answer By Call-Info”

1. Click the Profile.

2. Select the desired Profile from the pull-down list of Profile in the Profile field.
3. Click the advanced.
4. Enable the “Allow Auto Answer By Call-Info”.
5. Click the button to save the configuration.

Auto Answer No Yes

Allow Auto Answer by Call-Info No Yes
(Intercom)

Note:

This feature is not available on all servers. For more information, contact your system administrator.

DTMF

When the key is configured as DTMF key, You are allowed to send out the desired DTMF number during the conversation.

To use this feature, you should sure that the DTMF Tone is on.

To configure the DTMF via Web interface

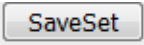
1. Click Setting → Preference.
2. Select On for Keypad DTMF Tone.
3. Click to  the configuration.

Keypad DTMF Tone On Off 

To configure the DTMF via Web interface

1. Click Function keys → EXP Key.
2. Select the desired Key and select DTMF in the Type.
3. Fill in the value with the Desired DTMF number.
4. Enter the Label displayed on LCD.
5. Click the  to save the configuration.

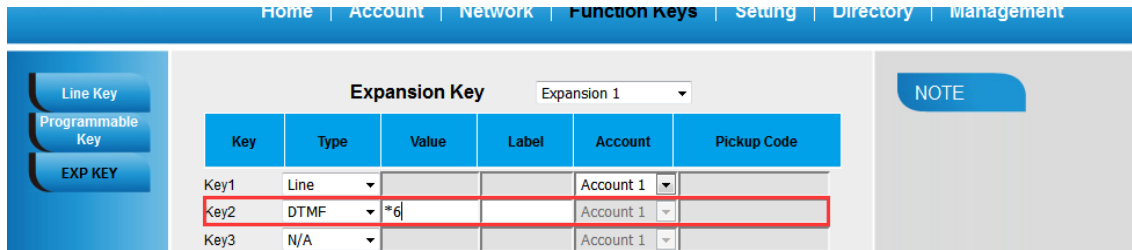

Prefix

If the key is configured as Prefix key, you can set the number prefix (e.g. Before the number plus 9), then you don't input 9, press the key and 9 will display on the LCD interface.

To configure the Prefix via Web interface

1. Click Function key → EXP Key.
2. Select the desired Key and select Prefix in the Type.
3. Fill in the value with number that you want to set as prefix
4. Enter Label displayed on LCD.
5. Click the to save the configuration.

Then when you press this key, the set value is input directly.

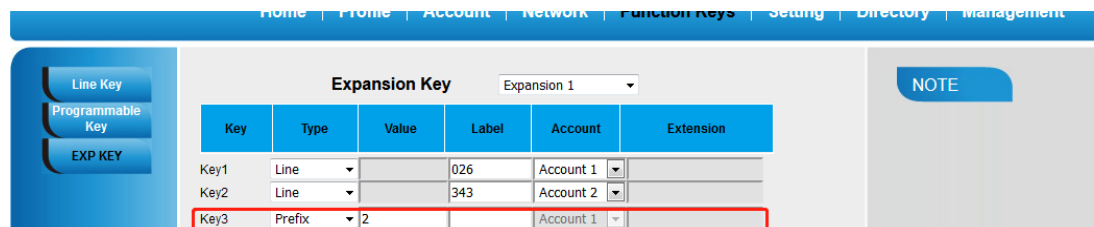

Local Group

When use the Local Group feature, press the key and enter the local Contacts interface quickly.

To configure the Local Group via Web interface

1. Click Function key → EXP Key.
2. Select the desired Key and select Local group in the Type.
3. Fill in the Label displayed on LCD.

- Click the  to save the configuration.

Then you can press the local group key to access the pre-defined contact group in the local directory quickly.

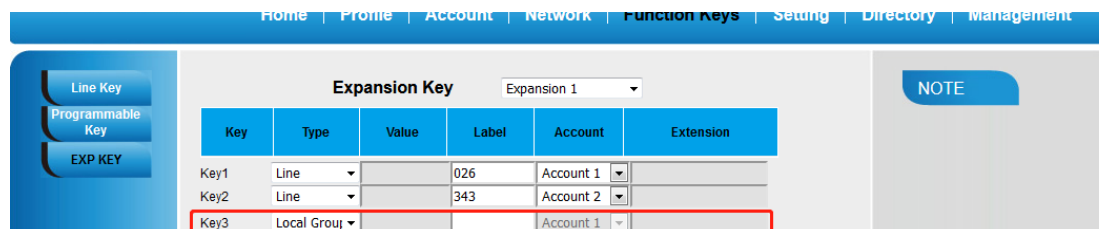

XML Group

When use the XML Group feature, press the key and enter the Remote Contacts interface quickly.

To configure the Local Group via Web interface

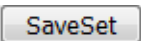
- Click Function key → EXP Key.
- Select the desired Key and select XML group in the Type.
- Fill in the Label displayed on LCD.
- Click the  to save the configuration.

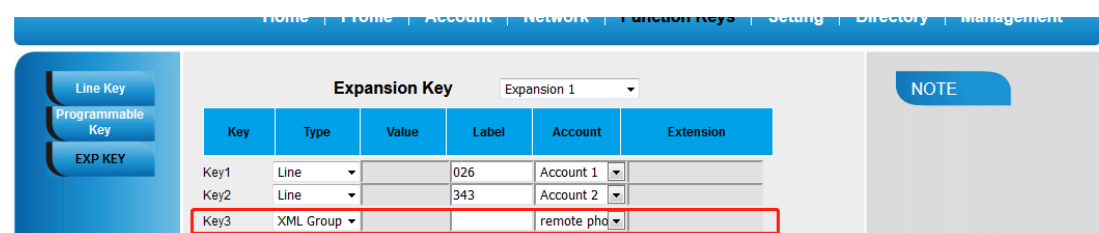

LDAP

When use the LDAP feature, you can get the LDAP Phonebook directly.

To configure the LDAP via Web interface

- Click Function key → EXP Key.
- Select the desired Key and select LDAP in the Type.
- Fill in the Label displayed on LCD.

- Click the  to save the configuration.

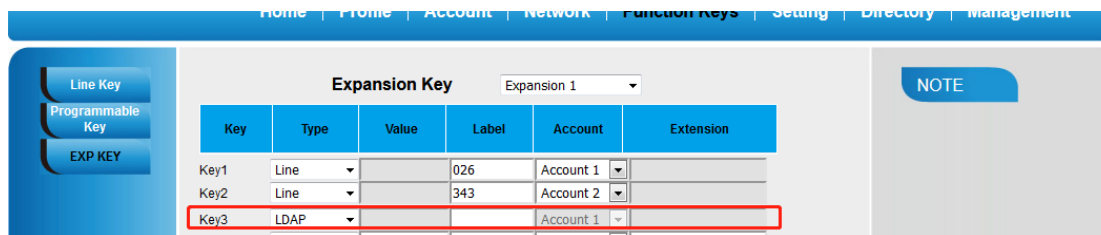

Network Directories

When use the Network Directories feature, press the key and enter the Remote Contacts interface quickly.

To configure the Network Directories via Web interface

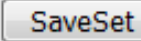
- Click Function key → EXP Key.
- Select the desired Key and select Network Directories in the Type.
- Fill in the Label displayed on LCD.
- Click the  to save the configuration.

Conference

You are allowed to configure the programmable key to be used as a conference key.

To configure Conference via Web Interface

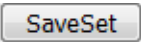
- Click Function keys →EXP Key.
- Select the desired Key and select Conference in the Type.
- Enter the Label displayed on LCD.
- Click the  to save the configuration.

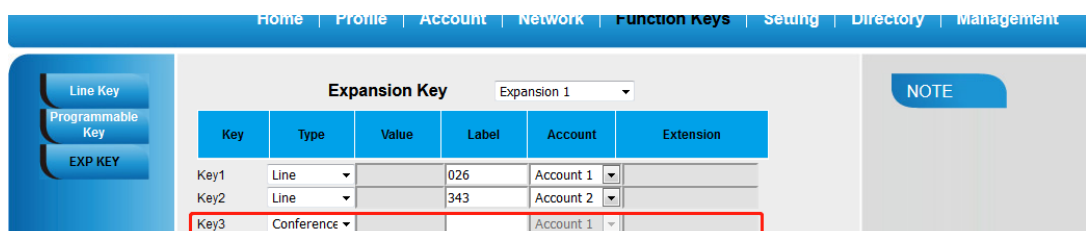

Forward

If the key is configured as Forward key, press this key under the idle status, the IP phone will turn to the Always Forward interface and you can set the Forward to number, then when there is any call to the Expansion number will be forwarded to the set number automatically.

To configure Forward via Web Interface

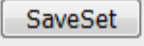
1. Click Function keys →EXP Key.
2. Select the desired Key and select Forward in the Type.
3. Enter the Value with the number you want to forward
4. Enter the Label displayed on LCD.
5. Click the  to save the configuration.

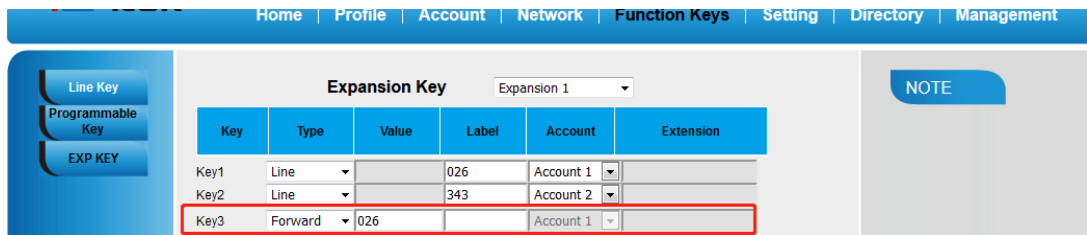

Home | Profile | Account | Network | **Function Keys** | Setting | Directory | Management

Line Key
Programmable Key
EXP KEY

Expansion Key Expansion 1

Key	Type	Value	Label	Account	Extension
Key1	Line		026	Account 1	
Key2	Line		343	Account 2	
Key3	Forward	026		Account 1	

NOTE

Transfer

You are able to configure the key as a transfer key to perform the Blind/Attended Transfer.

To configure Transfer via Web Interface

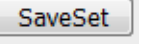
1. Click Function keys →EXP Key.
2. Select the desired Key and select Transfer in the Type.
3. Enter the Value with the number that wanted transfer to
4. Enter the Label displayed on LCD.
5. Click the  to save the configuration.

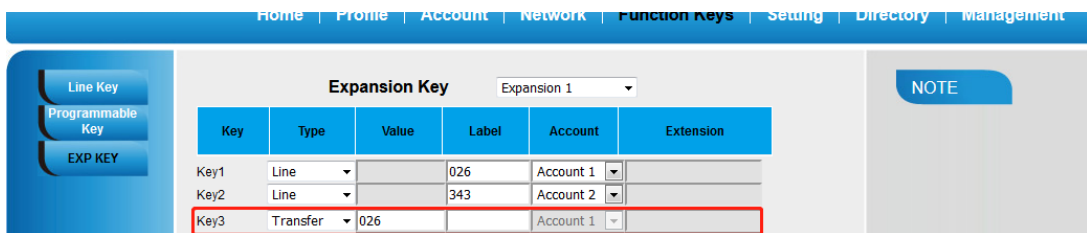

Home | Profile | Account | Network | **Function Keys** | Setting | Directory | Management

Line Key
Programmable Key
EXP KEY

Expansion Key Expansion 1

Key	Type	Value	Label	Account	Extension
Key1	Line		026	Account 1	
Key2	Line		343	Account 2	
Key3	Transfer	026		Account 1	

NOTE

Hold

The key can be configured as a hold key. You can use this key to hold and resume a call during the conversation.

To configure Hold via Web Interface

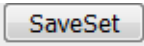
1. Click Function keys →EXP Key.
2. Select the desired Key and select Hold in the Type.
3. Enter the Label displayed on LCD.
4. Click the  to save the configuration.

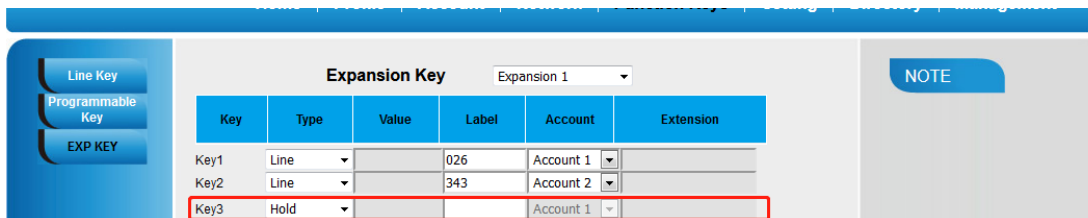

The screenshot shows the 'Expansion Key' configuration page. On the left, there are buttons for 'Line Key', 'Programmable Key', and 'EXP KEY'. The main area has a table with columns: Key, Type, Value, Label, Account, and Extension. The 'Type' dropdown for Key3 is set to 'Hold'. A 'NOTE' box is on the right.

Key	Type	Value	Label	Account	Extension
Key1	Line		026	Account 1	
Key2	Line		343	Account 2	
Key3	Hold			Account 1	

Group Listening

To configure Group listening via Web Interface

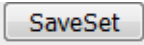
1. Click Function keys →EXP Key.
2. Select the desired Key and select Group listening in the Type.
3. Enter the Label displayed on LCD.
4. Click the  to save the configuration.

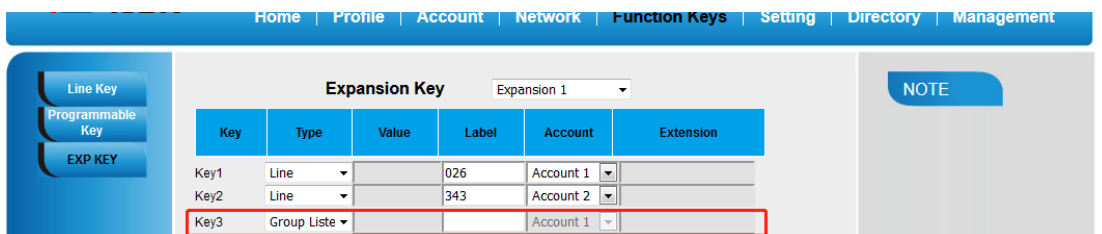

The screenshot shows the 'Expansion Key' configuration page. On the left, there are buttons for 'Line Key', 'Programmable Key', and 'EXP KEY'. The main area has a table with columns: Key, Type, Value, Label, Account, and Extension. The 'Type' dropdown for Key3 is set to 'Group Liste'. A 'NOTE' box is on the right.

Key	Type	Value	Label	Account	Extension
Key1	Line		026	Account 1	
Key2	Line		343	Account 2	
Key3	Group Liste			Account 1	

DND

If the key is configured as DND key, you are allowed to active the DND function immediately when you press it and the phone is to reject all incoming calls automatically. Press it again to deactivate DND mode.

To configure DND via Web Interface

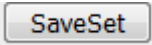
1. Click Function keys →EXP Key.
2. Select the desired Key and select DND in the Type.
3. Enter the Label displayed on LCD.
4. Click the  to save the configuration.

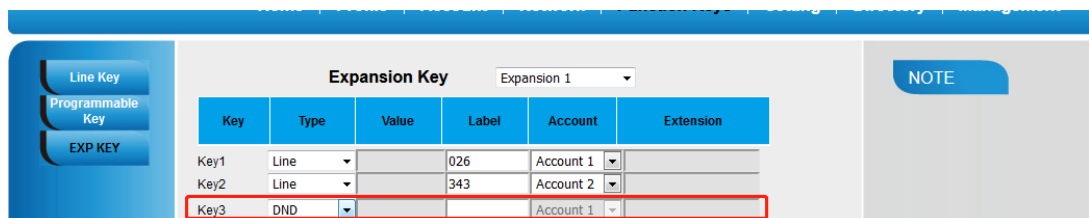

Key	Type	Value	Label	Account	Extension
Key1	Line		026	Account 1	
Key2	Line		343	Account 2	
Key3	DND			Account 1	

Redial

If the key is configured as Redial key, you can redial the last placed call from the IP Phone.

To configure Redial via Web Interface

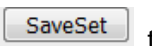
1. Click Function keys →EXP Key.
2. Select the desired Key and select redial in the Type.
3. Enter the Label displayed on LCD.
4. Click the  to save the configuration.

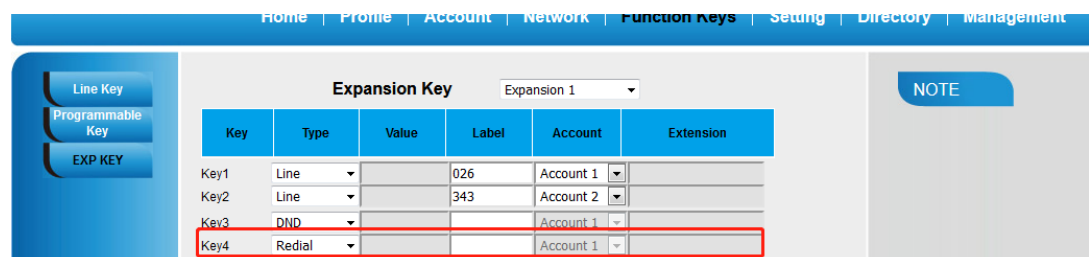

Key	Type	Value	Label	Account	Extension
Key1	Line		026	Account 1	
Key2	Line		343	Account 2	
Key3	DND			Account 1	
Key4	Redial			Account 1	

Call Return

When the key is configured as Call Return key you are allowed to dial out the last phone call you received.

To configure Call Return via Web Interface

1. Click Function keys →EXP Key.
2. Select the desired Key and select Call Return in the Type.
3. Enter the Label displayed on LCD.
4. Click the  to save the configuration.

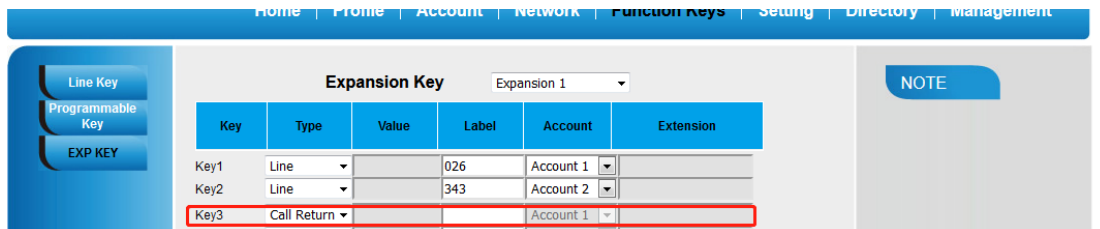

SMS

To configure SMS via Web Interface

1. Click Function keys →EXP Key.
2. Select the desired Key and select SMS in the Type.
3. Enter the Label.
4. Click the  to save the configuration.

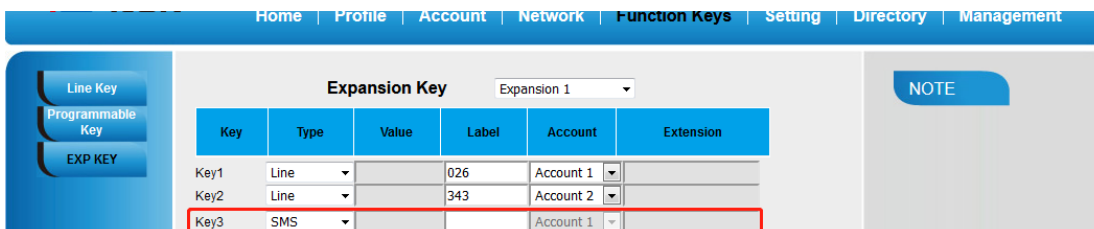

Record

With record feature, you can record calls by pressing a record key on the phone.

To configure the record via Web Interface

1. Click Function keys → EXP Key.
2. Select the desired Key and select Record in the Type.
3. Enter the Label displayed on LCD.
4. Click the  to save the configuration.

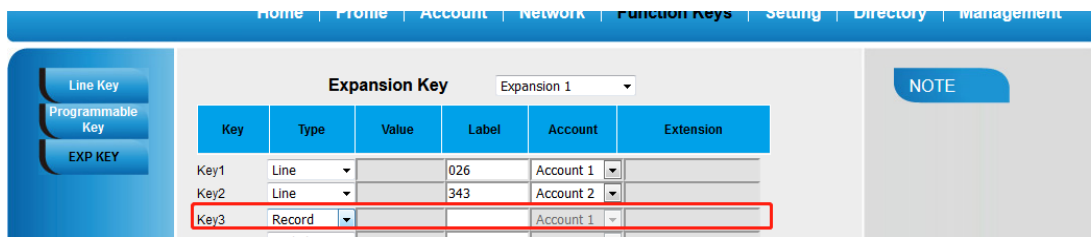

Note:

Please contact the system administrator whether support this feature or not.

URL Record

The phone sends HTTP URL request to trigger a recording. Contact your system administrator for the predefined URL.

To configure the record via Web Interface

1. Click Function keys → EXP Key.
2. Select the desired Line or Line Key and select URL Record in the Type.
3. Enter the Label displayed on LCD
4. Click the to save the configuration

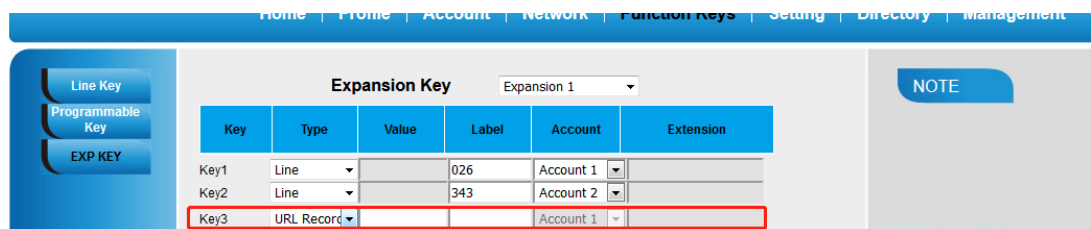

Paging

With this feature, you can call a phone or a group directly.

To configure the Paging via Web interface

1. Click Function keys → EXP Key.
2. Select the desired Key and select Paging in the Type.
3. Enter the Paging codes followed by phone number or group number
4. Enter the Label displayed on LCD.

- Click the  to save the configuration.

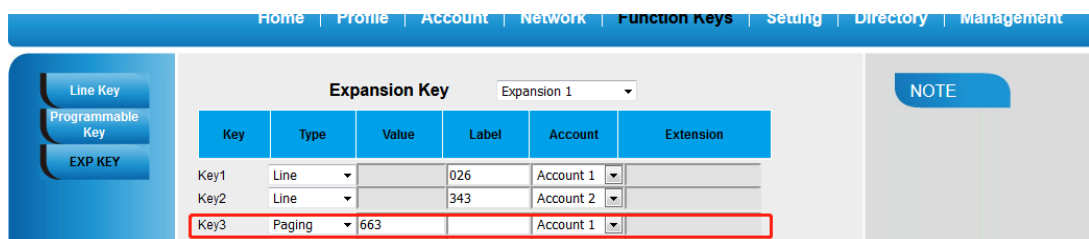

Home | Profile | Account | Network | **Function Keys** | Setting | Directory | Management

Line Key
Programmable Key
EXP KEY

Expansion Key Expansion 1

Key	Type	Value	Label	Account	Extension
Key1	Line		026	Account 1	
Key2	Line		343	Account 2	
Key3	Paging	663		Account 1	

NOTE

Public Hold

The key can be configured as a public hold key. During a conversation, all members belonging to that particular SLA group can use this key to hold or resume a call.

To configure public hold via Web Interface

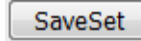
- Click Function keys →EXP Key.
- Select the desired Key and select public hold in the Type.
- Enter the Label displayed on LCD.
- Click the  to save the configuration.

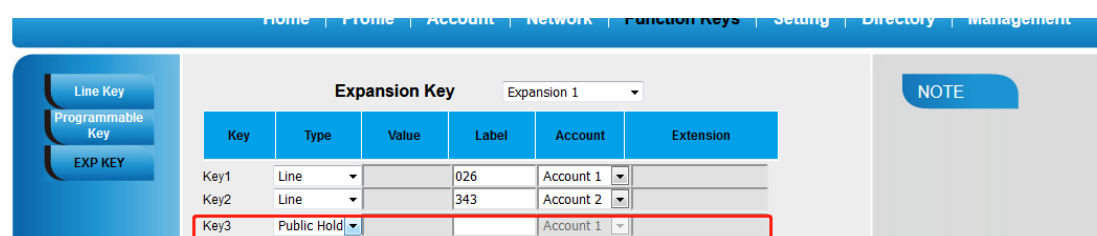

Home | Profile | Account | Network | **Function Keys** | Setting | Directory | Management

Line Key
Programmable Key
EXP KEY

Expansion Key Expansion 1

Key	Type	Value	Label	Account	Extension
Key1	Line		026	Account 1	
Key2	Line		343	Account 2	
Key3	Public Hold			Account 1	

NOTE

Private Hold

The key can be configured as a private hold key. During a conversation, all members belonging to that particular SLA group can use this key to hold the call, but only the initiator can resume the call.

To configure private hold via Web Interface

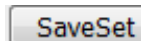
- Click Function keys →EXP Key.
- Select the desired Key and select public hold in the Type.
- Enter the Label displayed on LCD.
- Click the  to save the configuration.

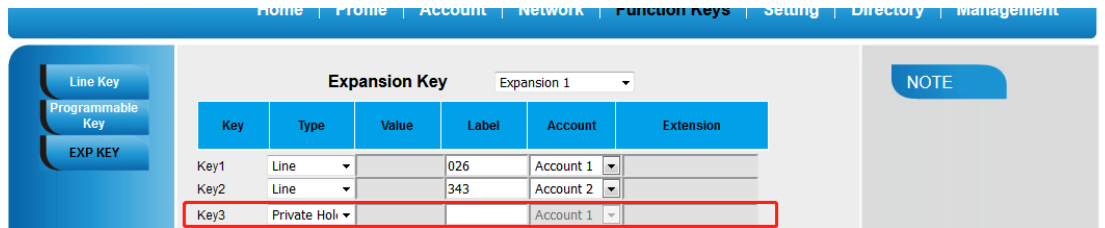

Hot Desking

To configure the hot desking via web interface:

1. Click Function keys →EXP Key.
2. Select the desired Key and select hot desking in the Type.
3. Enter the Label displayed on LCD.
4. Select the Account.
5. Click the to save the configuration.

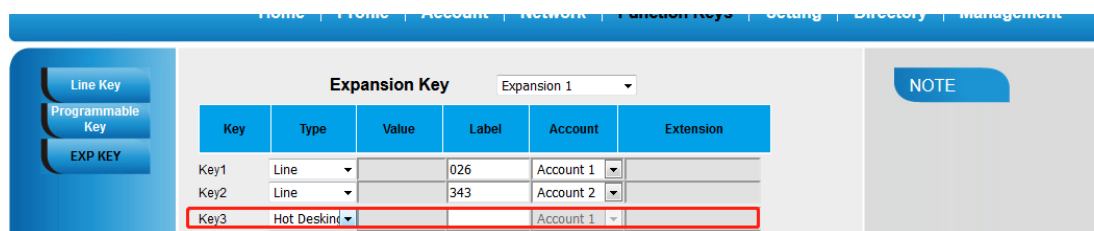

ACD

To configure the ACD via web interface:

1. Click Function keys →EXP Key.
2. Select the desired Key and select ACD in the Type.
3. Enter the Label displayed on LCD.
4. Select the Account.
5. Click the to save the configuration.

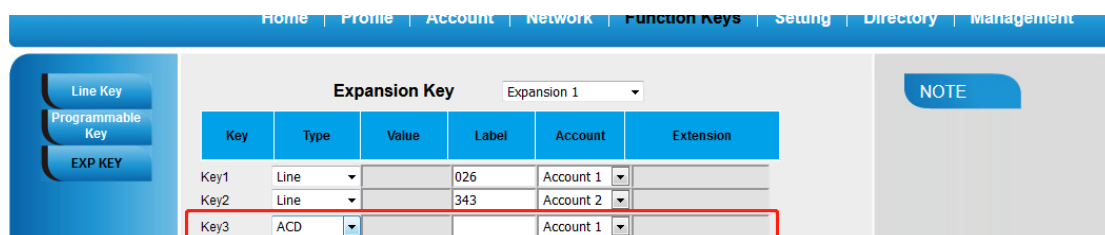

Zero Touch

To configure the Zero Touch via web interface:

1. Click Function keys →EXP Key.
2. Select the desired Key and select **Zero Touch** in the Type.
3. Enter the Label displayed on LCD.
4. Select the Account.
5. Click the  to save the configuration.

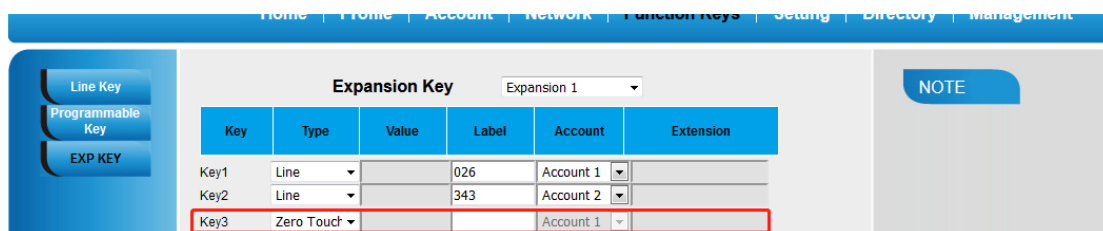

Home | Profile | Account | Network | Function Keys | Setting | Directory | Management

Line Key
Programmable Key
EXP KEY

Expansion Key Expansion 1

Key	Type	Value	Label	Account	Extension
Key1	Line		026	Account 1	
Key2	Line		343	Account 2	
Key3	Zero Touch			Account 1	

NOTE

URL

To configure the URL via web interface:

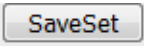
1. Click Function keys →EXP Key.
2. Select the desired Key and select **URL** in the Type.
3. Enter the Label displayed on LCD.
4. Click the  to save the configuration.

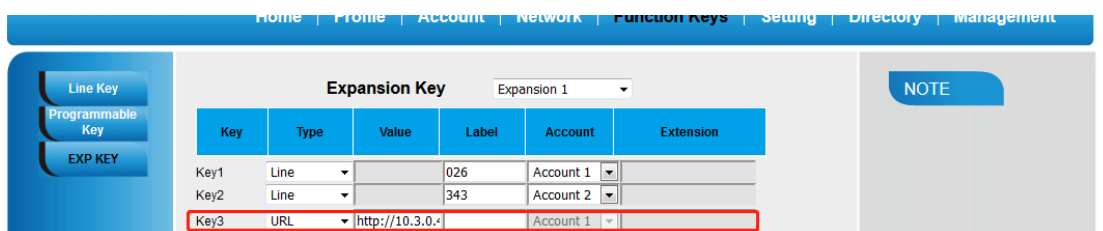

Home | Profile | Account | Network | Function Keys | Setting | Directory | Management

Line Key
Programmable Key
EXP KEY

Expansion Key Expansion 1

Key	Type	Value	Label	Account	Extension
Key1	Line		026	Account 1	
Key2	Line		343	Account 2	
Key3	URL	http://10.3.0.		Account 1	

NOTE

MultiCast Paging

To configure the MultiCast Paging via web interface:

1. Click Function keys →EXP Key.
2. Select the desired Key and select **MultiCast Paging** in the Type.

3. Enter the Label displayed on LCD.

4. Click the  to save the configuration.

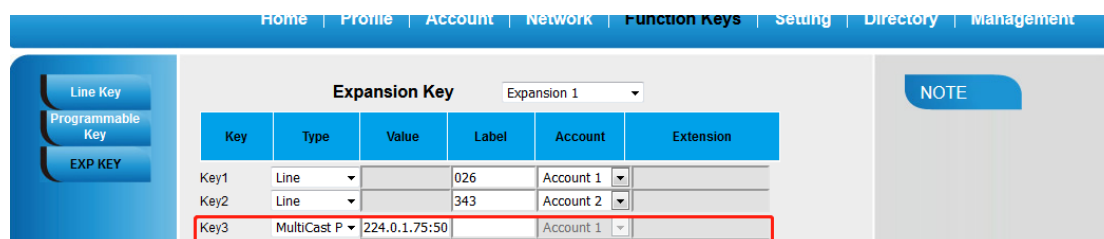

Upgrade

Xorcom UC42 Expansion Module upgrades in an indirect mode, first, the IP Phone that connects with expansion module upgrades the expansion module FW, then the expansion module upgrades via getting fw46M.rom file from the phone. For detailed schedule, please see below instruction.

IP Phone upgrades the expansion module FW

Before upgrade the expansion module, please make sure your IP Phone could upgrade the expansion module FW (we suggest your IP Phone's FW version running later **1.0.3.98 FW**). The instructions for upgrade the expansion module FW on your phone are as follows:

(1) First enable “**Upgrade EXP Firmware**” option from Management->Auto provision->Upgrade EXP Firmware

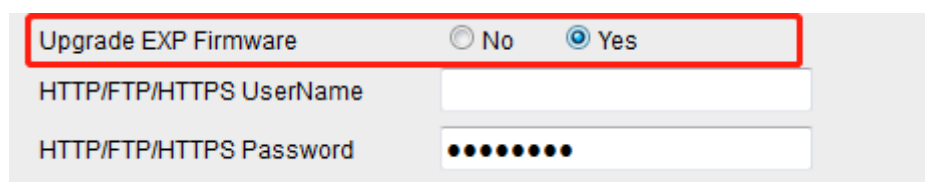

- If set this option to Yes, the IP Phone will get fw46M.rom file after rebooting IP Phone.
- If set this option to No, the IP Phone will not get fw46M.rom file.

(2) Put the fw46M.rom into the upgrade server path. You can upgrade by TFTP/HTTP/HTTPS/FTP.

(3) Set the server path at Webpage-Management-Auto Provision-Firmware Server Path.

(4) After you upgrade by TFTP/HTTP/HTTPS/FTP, please login Webpage->Home->Expansion Module version to check whether the expansion module FW has been Upgrade successfully. See below picture:

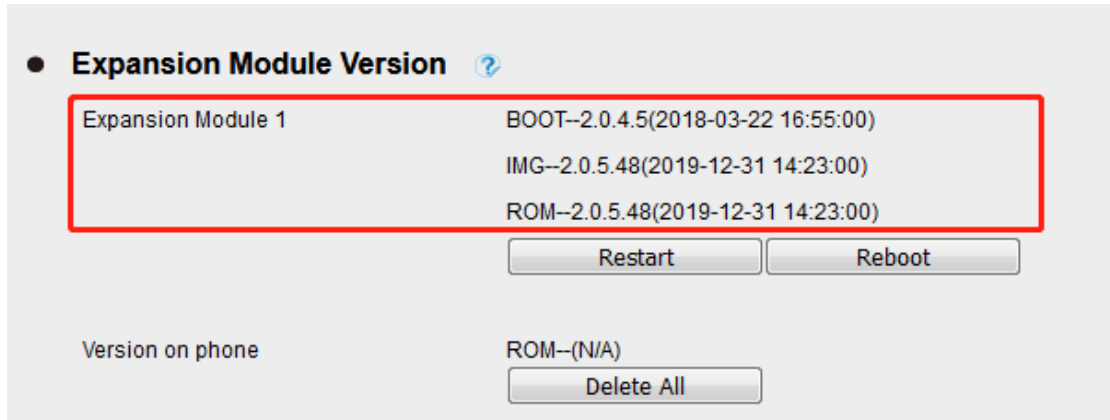

Expansion module gets the fw46M.rom from IP Phone

- (1) Before connecting the expansion module, please log on Webpage-Network-PC Port, choose to Connect to Expansion Module, and then click SaveSet. See below picture. Or Menu->Setting->Advanced Setting ->Network->PC port ->Connect to module on Phone LCD.



- (2) Connect Phone's PC port and UC42's Uplink port with Ethernet cable
- (3) Power up UC42 expansion module, then UC42 would automatically get the expansion module FW from the phone, and automatically restart to finish the upgrade.
- (4) After upgrade, please check whether the FW show on the phone status is same as the FW show on the Webpage, If it is same, it means that the FW has been upgraded successfully. Below picture for reference.

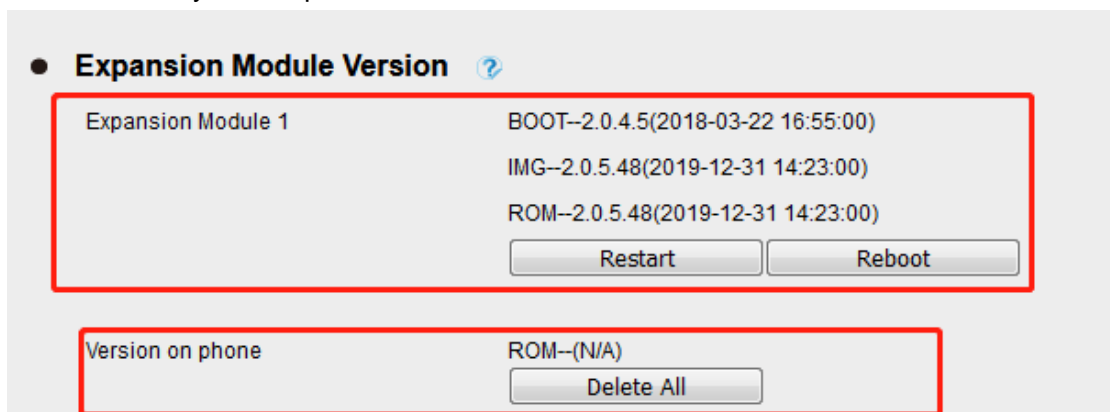

- (5) If expansion module FW did not upgrade successfully, please restart the expansion

module to upgrade the FW again.

Notes:

- 1. Please connect one expansion module with one phone for upgrade.**
- 2. Please do not power off the phone during the upgrade. Otherwise, it may cause damage to the phone and expansion module.**