



UC5xx Series IP Phone User Manual



Notices Information

Safety Instructions

- To use the Phone, please follow the instructions in this user manual.
- Use the power adapter supplied with your phone. Other power adapters may damage the phone.
- This phone is only for indoor use. And also avoid in high humidity, water and some other liquids.
- Do not use the phone during thunderstorms.
- CE
- FCC

WEEE Warning



To avoid the potential effects on the environment and human health as a result of the presence of hazardous substances in electrical and electronic equipment, end users of electrical and electronic equipment should understand the meaning of the crossed-out wheeled bin symbol. Do not dispose of WEEE as unsorted municipal waste and have to collect such WEEE separately.

Cleaning

To clean the device, use an anti-static cloth. Please avoid cleaning liquids as they might damage the surface or internal electronics of the phone.

FCC Statement

This device complies with Part 15 of the FCC Rules. Operation is subject to the following two conditions: (1) This device may not cause harmful interference, and (2) this device must accept any interference received, including interference that may cause undesired operation.

WARNING: Any changes or modifications not expressly approved by the party responsible for compliance could void the user's authority to operate this equipment.

NOTE: This equipment has been tested and found to comply with the limits for a Class B digital device, pursuant to Part 15 of the FCC Rules. These limits are designed to provide reasonable protection against harmful interference in a residential installation.

This equipment generates uses and can radiate radio frequency energy and, if not installed and used in accordance with the instructions, may cause harmful interference to radio communications.

However, there is no guarantee that interference will not occur in a particular installation. If this equipment does cause harmful interference to radio or television reception, which can be determined by turning the equipment off and on, the user is encouraged to try to correct the interference by one or more of the following measures:

- Reorient or relocate the receiving antenna.
- Increase the separation between the equipment and receiver.
- Connect the equipment into an outlet on a circuit different from that to which the receiver is connected.
- Consult the dealer or an experienced radio/TV technician for help.

*RF warning for Mobile device:

This equipment complies with FCC radiation exposure limits set forth for an uncontrolled environment. This equipment should be installed and operated with minimum distance 20cm between the radiator & your body.

Table of Content

Notices Information	2
Safety Instructions	2
WEEE Warning	2
Cleaning	2
FCC Statement	2
Table of Content	3
Before You Begin	7
Getting Started	8
Packing List	8
UC507U Packing List	8
Phone Installation	10
UC5xxU Phone Installation	10
Hardware Components Preview	11
Idle Screen	13
Initialization Process	14
Status	14
Registration	17
Getting Familiar with Your Phone	21
Icon Preview	21
LED Instruction	23
Power Indicator LED	24
Line LED (Line Key set as Line)	24
BLF or BLF List Key LED (Line/Line Key set as BLF)	24
Shared Line LED	24
User Interface	25
Call Features	26
Basic Call Features	26
Place a Call	26
End a Call	27
Redial a Call	27
Receive a Call	27
Incoming Call Show Mode	28
Auto Answer	28
Call Hold/Resume	28
Call Transfer	29
Call Conference	31
Call Forward	32
Call Return	35
Call Waiting Tone	36
Hide Caller ID	36
Reject Anonymous	37
Call Mute	38
DND	38
Hot Line	39
Auto Redial	39
Help center	40
Diagnostics	43
Power Saving	45
Advanced Call Features	45
Call Pickup	45
Group Pickup	46
Call Park	47
Busy Lamp Field (BLF)	47
Visual Alert for BLF Pickup	48
Audio Alert for BLF Pickup	49
BLF List	49

Share Line	50
Intercom.....	51
Intercom Barge.....	51
Short Message Service (SMS).....	52
Voice Mail	53
Using the Hot Desking.....	55
Automatic Call Distribution (ACD).....	55
Directory.....	56
Local Directory.....	56
Contact Groups	56
Managing the Local Directory Contacts	58
Moving a Local Directory Contact to Blacklist.....	60
Searching for Contacts.....	61
Upload Contacts photo.....	61
To import or export the contact list	63
Blacklist.....	63
Adding a Blacklist Contact	64
Viewing Blacklist Contacts	64
Editing a Blacklist Contact.....	64
Deleting Blacklist Contacts.....	65
Moving a Blacklist Contact to the Local Directory.....	65
Remote Phonebook.....	66
LDAP Phonebook	67
Call History Setting	69
Call History	69
Audio Settings.....	73
Ring Tone.....	73
Volume	75
Voice Mail Tone.....	76
Play Hold Tone.....	76
Play Hold Tone Delay	77
Voice	77
Handfree AGC	77
Volume Amplification	77
Handset Send Volume.....	77
Headset Send Volume.....	78
Handfree Send Volume	79
Extra Loud	79
USB.....	81
USB Recording.....	81
Manage your recordings	82
USB Headset.....	84
Adding a Wallpaper from a USB Flash Drive	84
Adding a Screen Saver from a USB Flash Driver	85
Bluetooth.....	85
How to Activate Bluetooth?.....	85
To activate Bluetooth via Phone interface:.....	85
How to Pair the Bluetooth Headset to the Phone?	86
Open the Bluetooth pairing mode on Bluetooth headset:.....	86
How to scan the Bluetooth headset device on phone interface:	86
How to edit device information?	88
How to edit device information on phone interface:.....	88
How to answer an incoming call?.....	89
How to adjust the earphone volume during a call?	89
How to End Call?.....	89
Wi-Fi.....	89
How to Enable Wi-Fi feature?.....	90
Enabling Wi-Fi feature via Phone interface:	90
How to Connect an Available Wireless Network?	90

Connect to an available wireless network via Phone interface:.....	90
How to view Wireless Network status?	92
How to Disconnect Wireless Network?	92
Disconnect wireless network via Phone interface:.....	92
How to Manually add a Wireless Network?.....	93
Add a Wireless Network Manually via Phone interface:	93
How to Disable Wi-Fi feature?.....	93
To disable the Wi-Fi feature via Phone interface:	93
Function Key	93
Line Keys	94
Line	94
Speed Dial	95
BLF	95
DTMF	96
Prefix	97
Local Group	97
XML Group	98
XML Browser	98
Network Directories	99
Conference	99
Forward	100
Transfer	101
Hold	101
DND	102
Redial	102
Record	103
URL Record	104
Paging	104
Group Listening	105
Public Hold	105
Private Hold	106
Zero Touch.....	106
Multicast Paging	107
Programmable Key	109
Customizing the Soft Keys	109
Customizing the hard Keys	110
Exp Key	111
Customizing Your Phone	112
Administrator Password.....	112
Language	113
Wallpaper	114
Screen Saver	115
Backlight	118
Time and Date	118
LED Status Setting	121
Key as Send	122
Dial Plan.....	122
Phone Lock.....	123
Emergency Call	124
Action URL.....	125
Softkey Layout	126
Settings	127
General Settings	127
Dial-Now Timeout	127
No Key Entry Timeout	128
Label Scroll.....	128
Show Missed Calls	128
Auto Logout Time	129
Reboot in Talking	129

Detect IP Conflict.....	129
Redial Mode	130
Suppress DTMF Display	130
Suppress DTMF Display Delay	130
Check-Syn With Authenticate.....	130
Headset Mode	130
Network setting.....	132
IPv4.....	132
IPv6.....	134
IPv4&IPv6.....	136
Preference (IPv4/IPv6).....	137
PC Port	137
System setting	138
Factory Reset	138
Pcap Feature	138
System Log.....	139
Upgrade.....	139
Configuration File	141
Optional Accessories with Your Phone	142
Headsets.....	142
Bluetooth Headset.....	142
Using Headsets	142
Expansion module	143
Connecting the Expansion Module	143
Troubleshooting	145
Why is the phone LCD screen blank?	145
Why does the phone display “Network Unavailable”?	145
Why can't I get a dial tone?	145
Where to set the tone?	145
How to download XML Configuration?	146
How to Import Trusted CA certificate?	146
How to Import Server CA certificate?	147

Before You Begin

This guide provides information you need to quickly use your new phone.

Firstly, verify with your system administrator that the IP network is ready for phone configuration. Also, be sure to read the Quick Start Guide which can be found in your phone package before you set up and use the phone. As you read this guide, keep in mind that some features are only configurable by your system administrator or determined by your phone environment. As a result, some features may not be enabled or may be operated differently on your phone. Additionally, the examples and graphics in this guide may not directly reflect what is displayed or is available on your phone screen.

Note: This guide mainly takes UC507U IP phones as an example.

This user guide contains information for the following products:

- UC507U Enterprise HD IP Phones
- UC505U Enterprise HD IP Phones
- UC503U Enterprise HD IP Phones
- UC503E Enterprise HD IP Phones
- UC503G Enterprise HD IP Phones
- UC503P Enterprise HD IP Phones
- UC501P Enterprise HD IP Phones
- UC507 Enterprise HD IP Phones
- UC505 Enterprise HD IP Phones
- UC503 Enterprise HD IP Phones
- UC501 Enterprise HD IP Phones

Getting Started

Packing List

UC507U Packing List

The package contains the following parts, please check if all the items are not missed:
1. The phone station

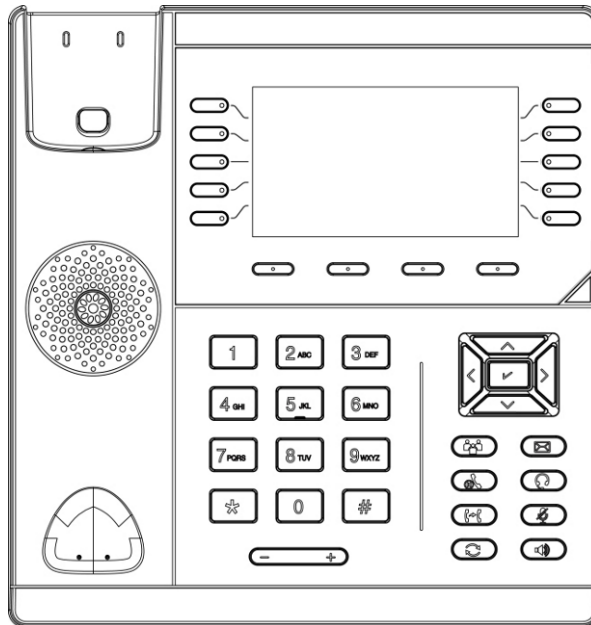

2. The phone stand

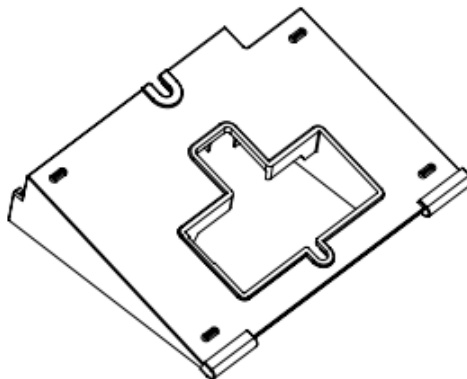

3. Handset

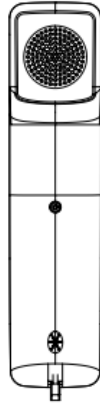

4. Headset cord

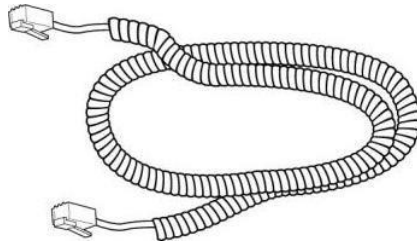

5. Power adapter

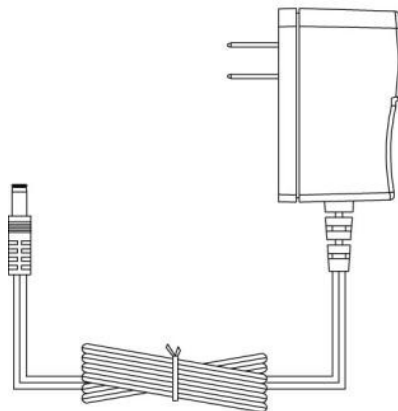

6. Ethernet cable

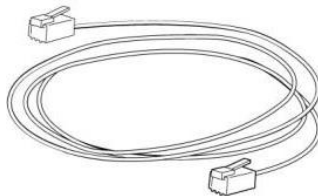

7. Quick installation reference



Phone Installation

UC5xxU Phone Installation

1. Attach the phone stand

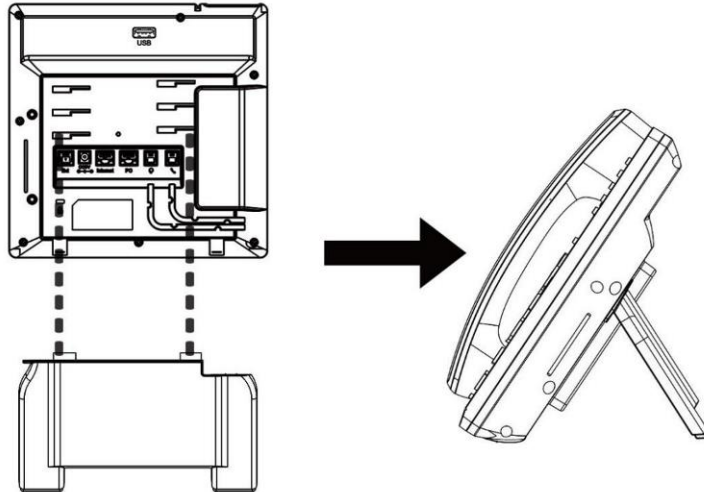

2. Connect the Handset and optional Headset

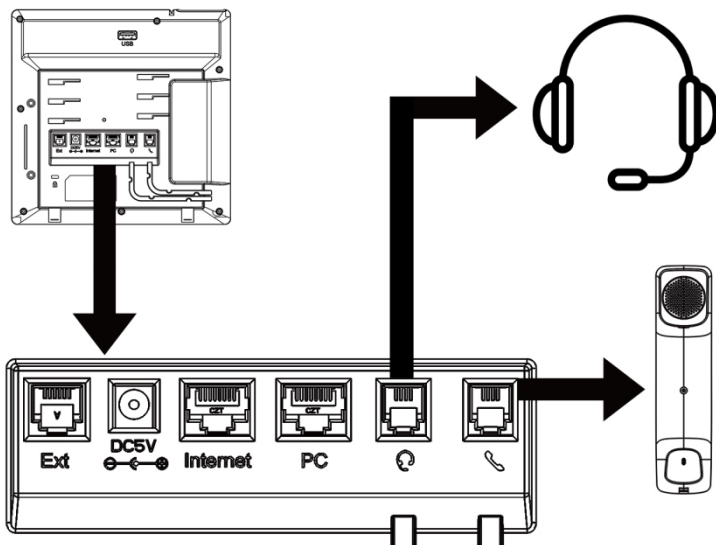

3. Connect the Network and Power

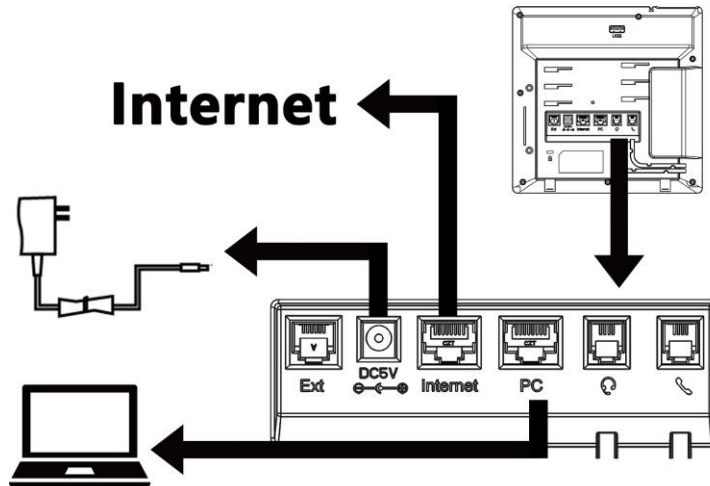

Hardware Components Preview

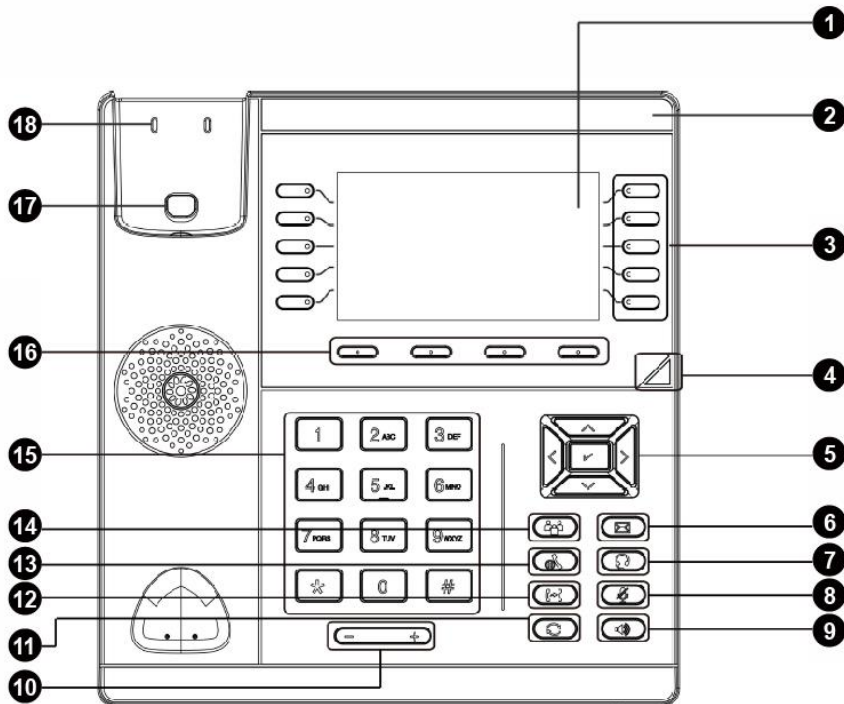

UC507U

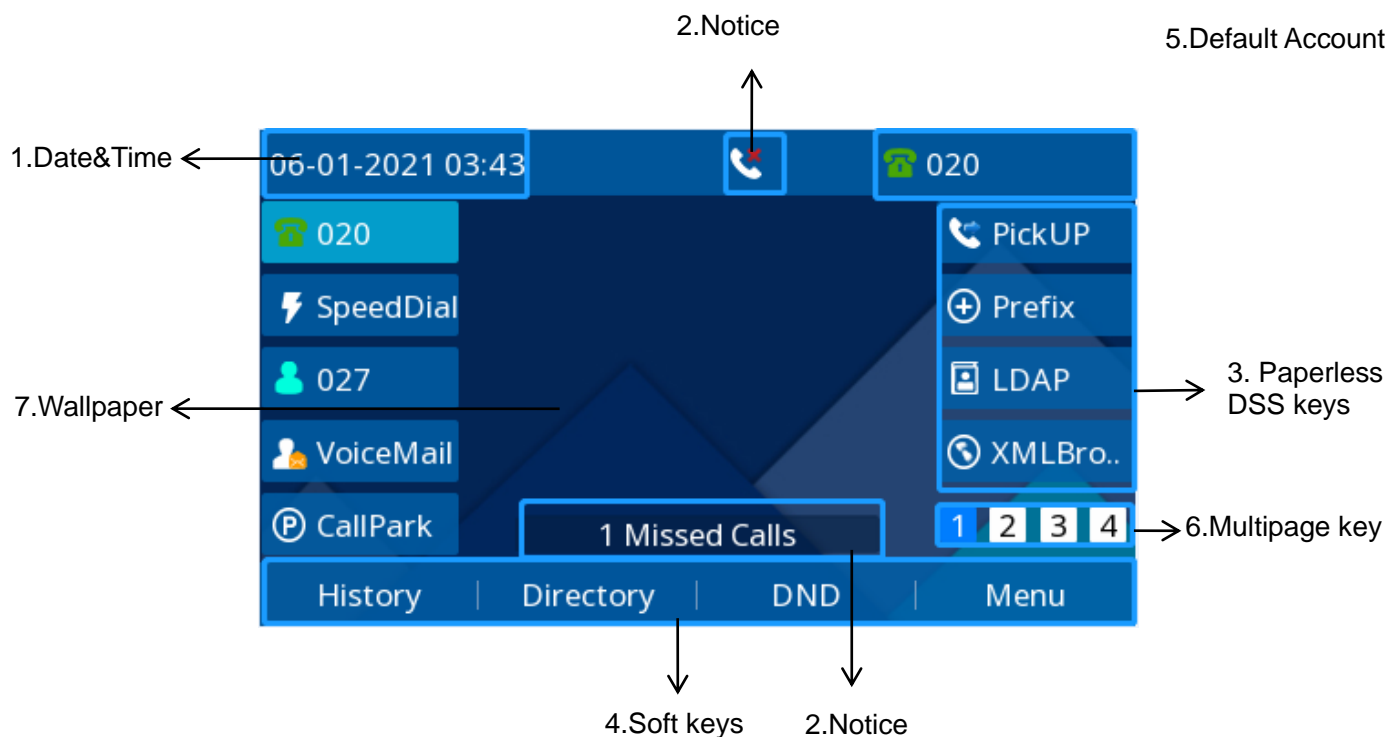

NO.	Item	Description
1	LCD Screen	To present all information about the date & time, accounts, soft keys, messages, calls and other some information.
2	Power Indicator LCD	To indicate the power status
3	Line keys	To be configured as different function.
4	Soft keys	Quickly access the functions displayed on the screen. The soft keys will change according to your current operation.
5	Navigation Keys	<p>Navigation Keys:</p> <ol style="list-style-type: none"> 1. Scroll the information or options displayed on the screen. 2. You can quickly access historical records and directories. <p>Up arrow key: History Down arrow key: Directory OK key:</p> <ol style="list-style-type: none"> 1. Can quickly enter the menu 2. Save the configuration 3. Answer the call
6	Message	Accesses your voice Mail.
7	Headset	To indicate that the phone is or not in Headset mode.
8	Mute	<ol style="list-style-type: none"> 1. To mute the voice during the call (Red light). 2. To un-mute the call.
9	Speakerphone key	Press this button to place a call-in hands-free mode.
10	Alphanumeric Keypad	To enter the phone numbers, letters and so on.
11	Volume Keys	To decrease and increase the volume.
12	Redial	To dial the previous dialed number. To act as send key.
13	Transfer	To transfer a call to a third party. To enable or disable Forward feature during the idle page.
14	Hold	To hold or to resume a call during a conversation.
15	Conference	To place a conference call.
16	Speaker	Provides hands-free (speakerphone) audio output.
17	Reversible Tab	Secures the handset in the handset cradle when the phone is mounted vertically.
18	Hookswitch	Connects or disconnects the phone from the phone line. The hookswitch is automatically activated when a user lifts the handset from the cradle to get a dial tone.

Idle Screen



Name	Description
1. Date & Time	It is the area that displays the current set date and time of the phone.
2. Notice	It is the area to display the phone's notifications such as missed calls, SMS, do not disturb mode and many more. For more info, see Icon Preview .
3. Paperless DSS Keys	This area shows the line key labels. The Line keys can also be used for other function keys. For more info, you can refer to Line Keys
4. Soft Keys	This area shows the soft key labels. The default soft key labels are "History", "Directory", "DND" and "Menu". For more info, see Programmable Key
5. Default Account	This shows the current use account. User can use   to change the default use account.
6. Multipage Key	UC507U support 36 keys, you can configure different types. You can view and use these keys by pressing the multipage key.
7. Wallpaper	This shows the current wallpaper picture. You can also change it. For more info, you can refer to Wallpaper .

Initialization Process

After your phone has been powered up, the system boots up and performs the following steps:
Automatic Phone Initialization.

The phone finishes the initialization process by loading the saved configuration. The phone LCD screen will display "Booting".

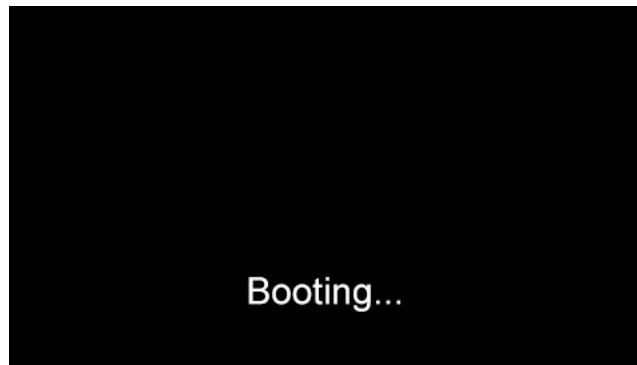

Then show "Initializing" during the initialization, and all the indicators on the phone LCD are always on.



Status

You can view the system status of your phone via phone user interface or web user interface. The information of phone status includes Information (e.g., Model, IPV4, IPV6, MAC, Firmware, Hardware), Network (e.g., WAN Type, IP, Mask, LAN Type, Gateway, DNS ...), Accounts (e.g., register status of accounts)

To view the phone status via Phone interface:

1. Press Menu→ Status→ Information

Information	
1. Model:	UC507U
2. IPV4:	10.20.0.34
3. MAC:	00:1f:c1:1f:34:60
4. Wifi MAC:	10:d0:7a:c2:5d:e7
5. Firmware(IMG):	0.0.0.1(Dec 29 2020 09:53:17)

Back

2. Press Menu→ Status→ Network

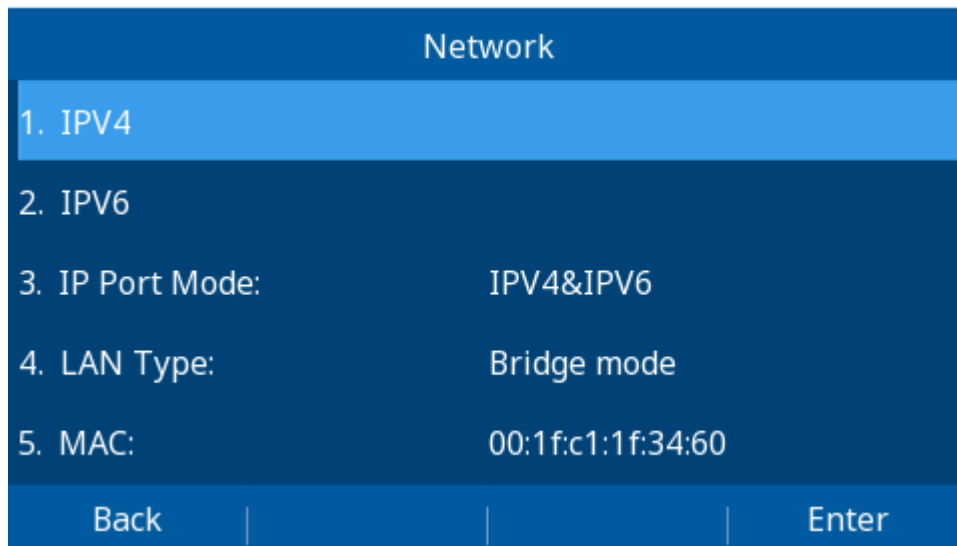

3. Press Menu→ Status→ Network→ IPV4

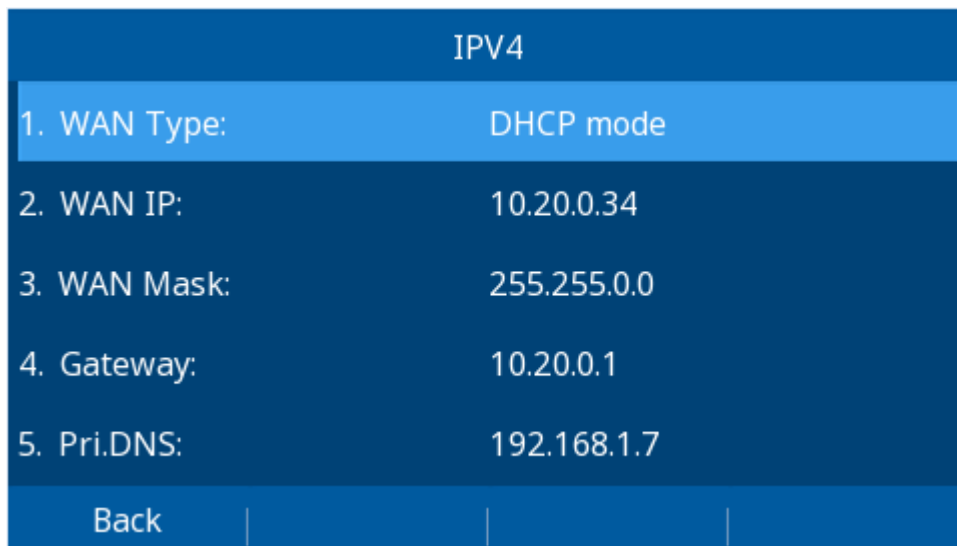

4. Press Menu→ Status→ Network→ IPV6

IPV6	
1. WAN Type:	DHCP mode
2. WAN IP:	2001:12d0:8000:0:21f:c1ff:fe1f
3. Gateway:	fe80::21f:c9ff:fe17:9fc4/64
4. Pri.DNS:	2001:12d0:8000:3000::1117
5. Sec.DNS:	2001:12d0:8000:3000:192:168:1
Back	

5. Press Menu→ Status→ Accounts

Accounts	
1. 020:	Registered
2. 456:	Not Registered
3. Empty:	Not Registered
4. Empty:	Not Registered
5. Empty:	Not Registered
Back	

To view the phone status via Web interface:

1. Login webpage
2. Input the IP Address in the web browser.
3. Input the username (default is admin), password (default is admin).
4. Login successfully.

View the information of Version, Account Status and Network.

The screenshot shows the IP PHONE web interface. At the top, there is a navigation bar with the title 'IP PHONE' and several menu items: Home, Profile, Account, Network, Function Keys, Setting, Directory, and Management. Below the navigation bar, the main content area is divided into sections. On the left, there is a 'Status' section. In the center, there is a 'Version' section with a sub-section for 'Firmware Version' listing several components: BOOT-0.21.1.6(2021-01-06 00:14:00), IMG-0.0.0.1(Jan 6 2021 00:12:58), ROOTFS-0.21.1.6(2021-01-06 00:14:00), ROM-0.21.1.6.218(2021-01-06 00:14:00), and DSP-9.0.3(Patch 1.0.16D). On the right, there is a 'NOTE' section with two sub-sections: 'Version:' which states 'Shows product type and the version of firmware.', and 'Account Status:' which states 'Shows the registered status of accounts.'

Note:

The PC and phone should be in the same segment.

When registering the accounts in web and the server port is not “5060”, the SIP Server should be set as SIP Server’s IP address: server port, for example, 192.168.0.12:5090.

Registration

To register via Phone interface

1. Press Menu→ Settings→ Advanced Setting (default password: admin) → Accounts
2. Select the desired account.
3. Select Enable for Active.
4. Select the desired Profile of the account.
5. Fill in the SIP User ID, Authenticate ID.
6. Fill in the Password and Name (shown on LCD).
7. Press Save soft key to save the configuration.

020		
1. Active:	Enable <>	
2. Profile:	Profile 1 <>	
3. SIP User ID:	020	
4. Authenticate ID:	020	
5. Password:	•••••	
Cancel	Switch	Save

Note:

If there is a port of sip server, you need to press “1” on the keypad, then you will find the “:”.

Additional Information

When the current input method is ABC/abc/2ab,

Pressing “1”, you will find “, . ? : ;”

Pressing “0”, you will find “< > () { } [] _ -”

Pressing “*”, you will find “*^ “ ! @ \$ = + ‘ % & | ~ ^”

Pressing “#”, you will find “#”

To register via Web interface

1. Login webpage and Click Profile→ Basic
2. Select the desired profile from the pull-down list of Profile field.

Basic

Codec

Advanced

Profile Profile 1 ▾

* Primary SIP Server ?

Failover SIP Server ?

Second Failover SipServer ?

Prefer Primary SIP Server No Yes ?

Current SIP Server

DHCP SIP Server No Yes

Outbound Proxy ?

Backup Outbound Proxy ?

* SIP Transport UDP TCP TLS ?

NAT Traversal No No, but send keep alive STUN

DNS Mode A Record SRV NAPTR/SRV

Call Message Format ▾

Transfer Release Trigger: ▾

SIP Registration No Yes

Unregister On Reboot No Yes

Register Expiration ?

Fallback Interval ?

Outgoing Call Without Registration No Yes

RPort No Yes

RFC 2543 Hold No Yes

NOTE

The * fields must be filled (requires a phone restart)

Basic:
The Basic parameters configured by the administrator.

Codecs:
Select the codec you want to use.

Advanced:
The advanced parameters configured by the administrator.

3. Fill in the Primary SIP Server and other profile information.
4. Select the SIP Transport.
5. Click to save the configuration.
6. Click Account→ Basic.
7. Select the desired account from the pull-down list of Account field.

Basic

Account

Account 1

Account Status: 020@10.13.0.12:5060 : Registered, UDP

* Account Active No Yes

Profile: Profile 1

Label: ?

* SIP User ID: 020 ?

* Authenticate ID: 020 ?

* Authenticate Password: ●●●●●● ?

Name: ?

Local SIP Port: 5060 ?

Use Random Port: No Yes

Voice Mail UserID: ?

Dial Plan: {[x*]+}

Eventlist BLF URL:

Shared Line: Disable

SCA Barge-In: Disable ?

Direct Call Pickup Code: *20*

Group Call Pickup Code:

Feature Key Sync: Disable

NOTE

The * fields must be filled (requires a phone restart)

Basic:
The Basic parameters configured by the administrator.

8. Select Yes for Account Active.
9. Select the desired Profile.
10. Fill in the SIP User ID, Authenticate ID, Authenticate Password, and other account information.
11. Click SaveSet to save the configuration.

To register via DHCP SIP Server

1. Login web page and Click Profile→ Basic
2. Select the desired profile from the pull-down list of Profile field.

Basic

Codec

Advanced

Profile Profile 1 ▾

* Primary SIP Server ?

Failover SIP Server ?

Second Failover SipServer ?

Prefer Primary SIP Server No Yes ?

Current SIP Server

DHCP SIP Server No Yes

Outbound Proxy ?

Backup Outbound Proxy ?

* SIP Transport UDP TCP TLS ?

NAT Traversal No No, but send keep alive STUN

DNS Mode A Record SRV NAPTR/SRV

Call Message Format

Transfer Release Trigger:

SIP Registration No Yes

Unregister On Reboot No Yes

Register Expiration ?

Fallback Interval ?

Outgoing Call Without Registration No Yes

RPort No Yes

NOTE

The * fields must be filled (requires a phone restart)

Basic:
The Basic parameters configured by the administrator.

Codecs:
Select the codec you want to use.

Advanced:
The advanced parameters configured by the administrator.

3. Fill in the Primary SIP Server and other profile information.
4. Select Yes for the DHCP SIP Server and select the SIP Transport.
5. Click to save the configuration.
6. Click Account→ Basic.
7. Select the desired account from the pull-down list of Account field.

Basic

Account Account 1

Account Status: 020@10.13.0.12:5060 : Registered; UDP

* Account Active No Yes

Profile: Profile 1

Label:

* SIP User ID: 020

* Authenticate ID: 020

* Authenticate Password: ●●●●●●

Name:

Local SIP Port: 5060

Use Random Port: No Yes

Voice Mail UserID:

Dial Plan: {[x*]+}

Eventlist BLF URL:

Shared Line: Disable

SCA Barge-In: Disable

Direct Call Pickup Code: *20*

Group Call Pickup Code:

Feature Key Sync: Disable

NOTE

The * fields must be filled (requires a phone restart)

Basic:
The Basic parameters configured by the administrator.











8. Select Yes for Account Active.
9. Select the desired Profile.
10. Fill in the SIP User ID, Authenticate ID, Authenticate Password and other account information.
11. Click SaveSet to save the configuration.





































Note:









1. All fields with * must be filled.
2. Account Status says the account registered successfully or not.

Getting Familiar with Your Phone

Icon Preview

Icon	Description	Icon	Description
	Network down		Call Park
	Line (Registered succeed)		Intercom
	Line (Unregistered)		Prefix
	Line (Ringing)		XmlGroup
	Speed Dial		LocalGroup

	BLF (No subscription)		XmlBrowser
	BLF(Free)		LDAP
	BLF(Ring)		Broadsoft Group
	BLF(Talking)		Forward
	Speakerphone mode		Transfer
	Handset mode		Redial
	Headset mode		Call Return
	Voice mail		Record
	Text message		Stop Recording
	Mute		Group Listening
	DND		Multipaging
	Volume is 0		ParkRetrieve
	SRTP		Share Line
	Hold (DSS key)		SMS
	hold		URL
	Dialed/PickUp		Bluetooth mode is on
	Received calls		Bluetooth headset is both paired and connected
	Missed calls		VPN

	Forward		Wi-Fi obtaining
	Conference		Wi-Fi connection is successful
	Keypad locked		Wi-Fi Disconnected
	DTMF		ZRTP

LED Instruction

This part mainly instructs the LED status. The Power LED Status describe on the premise that the LED setting all set as Yes. For LED status setting, please refer to: [LED Status Setting](#)

Power Indicator LED

LED Status	Description
Blinked green	Ringling or have missed call
Steady Green	Idle status (Power on)
Off	Powered off

Line LED (Line Key set as Line)

LED Status	Description
Slowly flashing green	The call is placed on hold.
Steady Green	Off hook or during a conversation.
Fast-flashing red	The line receives an incoming call.
Off	Idle status

BLF or BLF List Key LED (Line/Line Key set as BLF)

LED Status	Description
Steady Green	Idle status for the monitored line.
Steady Red	The monitored line is in the conversation or making a call.
Blinked red	The monitored line is receiving an incoming call.
Off	No subscription or Account dropped.

Shared Line LED

LED Status	Description
off	Idle status
Stay green	a member of the SCA group in off-hook status
Stay red	Other member of the SCA group's led status when a member of the SCA group in off-hook status
Blinked green every 500ms	a member of the SCA group in Private hold status.
Stay red	Other member of the SCA group's led status when a member of the SCA group in Private hold status
Blinked green every 500ms	a member of the SCA group in public hold status

Blinked red every 500ms	Other member of the SCA group's led status when a member of the SCA group in public hold status
Blinked green every 500ms	a member of the SCA group in progressing status
Stay red	Other member of the SCA group's led status when a member of the SCA group is in progressing status.
Blinked red every 100ms	Alerting
Stay green	a member of the SCA group in active status when there is an incoming call designated for the SCA group
Stay red	Other member of the SCA group's led status when a member of the SCA group in active status

User Interface

There are two ways to customize specific configurations on your IP phone:

- The user interface on the IP phone
- The user interface in a web browser on your PC

The hardware components keypad and LCD screen constitute the phone user interface, which allows the user to execute all call operation tasks and basic configuration changes directly on the phone. In addition, you can use the web user interface to access all configuration settings. In many instances, it is possible to use both the phone user interface and the web user interface to operate the phone and change settings. However, in some instances, it is only possible to use the phone or the web user interface.

Phone Interface Overview

Option	
Status	Information
	Network
	Accounts
Features	Forward
	Function Keys
	More Key see Function Key
	# as Send Key
	Hot Line
	Anonymous Call
	DND
	History
Directory	Diagnostics
	Local Contacts
	Remote Contacts (When you use remote, It will display)
	AP Contacts (When you use AP contacts, It will display)
	LDAP Contacts (When you use LDAP, It will display)
BlackList	
History	All Calls/Missed Calls/Dialed Calls/Received Calls/Forwarded Calls
Messages	Voice Mail
	SMS

Settings	Basic Setting	Language
		Time & Date
		Time & Date Format
		DHCP Time
		Ring Tone
		Headset
		Bluetooth (If support)
		Wi-Fi (If support)
		Font Size
		Text Scroll
	Advanced Setting	Accounts
		Network
		Phone Setting
Auto Provision		
Display	Wallpaper	
	Screensaver	
	Backlight	
Others	Factory Function	
	Reboot	

Call Features

Basic Call Features

Place a Call

There are three ways to dialing a call: Handset, Headset and Speakerphone.

To place a call by Handset:

1. Pick up the handset.
2. Enter the number.
3. Press the Send soft key.

To place a call by Headset:

1. Press the Handset hard key  (light will be green).
2. Enter the number.
3. Press the Send soft key.

Using headset to place and answer calls for all time:

1. Login webpage, and click Setting→ Preference
2. Set Headset Priority→ Enable
3. Set Ring Device for Headset→ User Headset

HeadSet Priority	Enable ▼
Ringer Device For HeadSet	Use HeadSet ▼

4. Click to save the setting.
5. Press .

To place a call by speakerphone:

1. Press the Speakerphone key , or press the Line key, then you can hear the dial tone.
2. Press the number.
3. Press the Send soft key.

To place a call from Call History:

1. Press the History soft key or navigate to Menu → History → Local History.
2. Select the desired call history.
3. Press the Send soft key.

To place a call from Directory:

1. Press the Directory soft key or navigate to Menu → Directory → Local Contacts.
2. Select the desired contact from a contact group.
3. Press the Send soft key.

Note:

1. The  key can be set as **Send** key. For more information, refer to [Key as Send](#).
2. During a call, you can also change among Headset, Handset or Speakerphone mode.

Making multiple calls

When you are in a call, you can hold your current call and place a new call.

1. Press Hold soft key to place the current call on hold.
2. Press New Call soft key.
3. Dial another number,
4. Press the Send soft key.

End a Call

To end a call by Handset

In handset mode, press the **EndCall** soft key or hang up the handset.

To end a call under Headset Mode

In headset mode, press the **EndCall** soft key or press .

To end a call under Speakerphone Mode

In speakerphone mode, press the **EndCall** soft key or press .

Note:

During the conference, to end the call is same as mentioned above.

Redial a Call

To redial the last placed call from the IP Phone:

Press  directly when LCD is on the idle interface.

Receive a Call

There are three ways to receive a call when the phone is ringing:

To receive a call by handset

Pick up the handset and now the conversation is built.

To receive a call by headset

Press  and now the conversation is built.

To receive a call by hands-free speakerphone

1. Option 1: Press  directly.
2. Option 2: Press Answer soft key.

3. Option 3: Press the Line key (flashes red).

Moreover, some other action can be done by soft key when the call is coming.

1. Press the Reject soft key to reject the call.
2. Press Forward soft key to forward to another phone.
3. Press Silence soft key, and then the call will keep silent, no ring tone display.

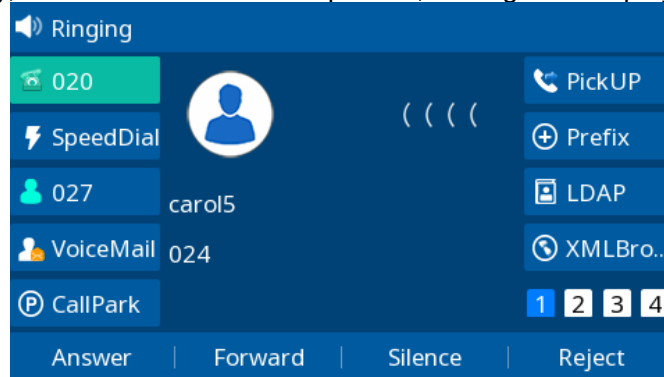

Incoming Call Show Mode

There are two incoming call show modes for this phone:

1. name of the contacts.
2. name and number of the contacts.

To set Incoming Call Show Mode via Web interface:

1. Click Setting→ Preference
2. Select the desire mode for the Incoming Call Show Mode
3. Click **SaveSet**.

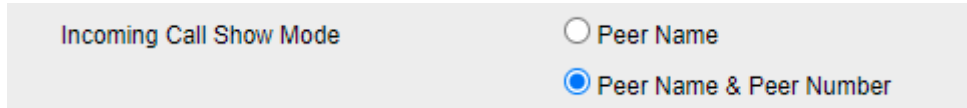

Auto Answer

Enable Auto Answer feature, you will answer all incoming call automatically.

To enable Auto Answer via Web interface:

1. Click **Profile** → **Advanced**.
 - a) (If you want to set profile except Profile 1, please select the corresponding profile from the pull-down list in the Profile field)
2. Switch the option to **Yes**.

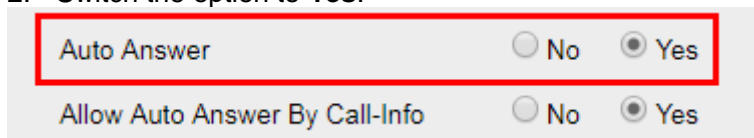

3. Click **SaveSet**.

Call Hold/Resume

When using the Hold feature, the held party may hear music played by the server.

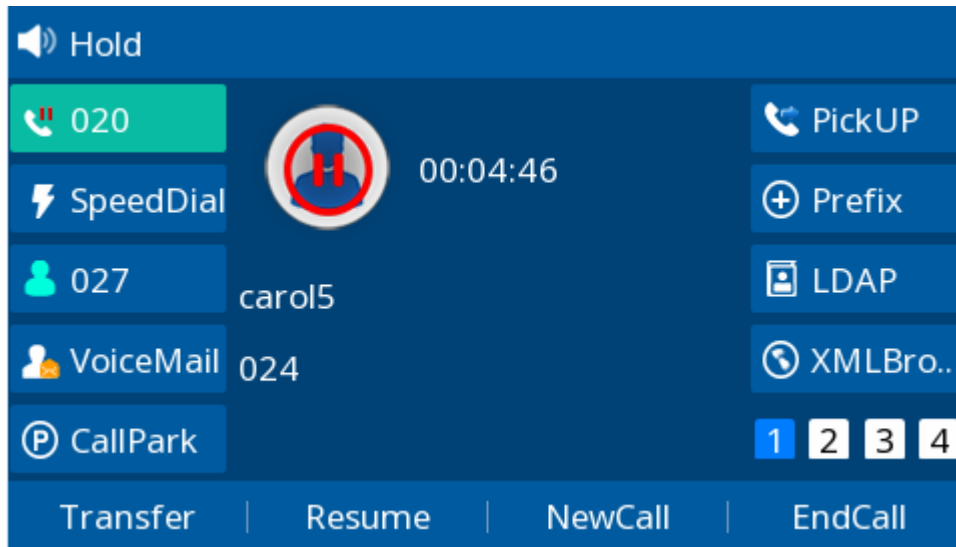

To hold/resume a call:

1. Press Hold soft key to hold the current call.
2. Press Resume soft key to resume the call on hold.

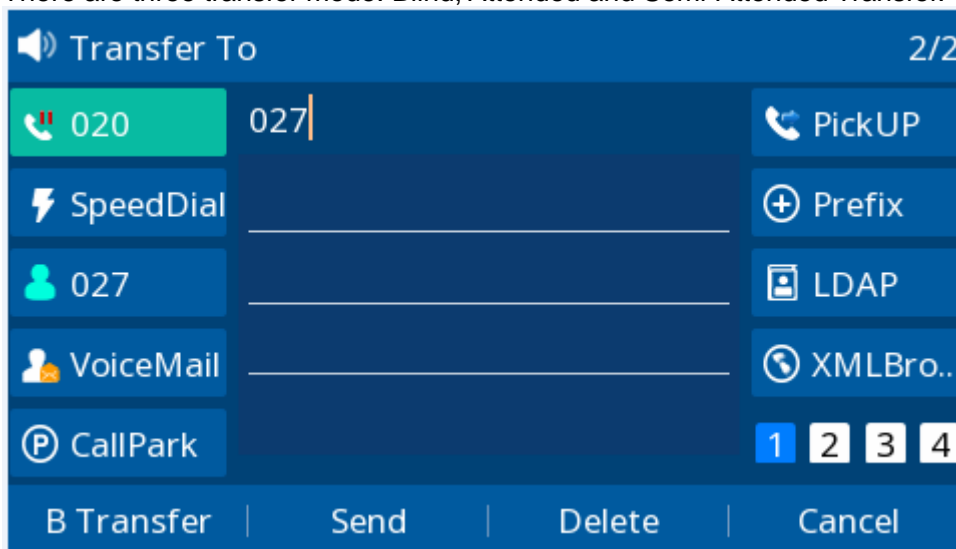

Call Transfer

There are three transfer mode: Blind, Attended and Semi-Attended Transfer.





Blind Transfer

When you are in a call,

1. Press  or **Transfer** soft key, the current call will be holding.
2. Enter the number you want to transfer to.
3. Press  or **B Transfer** soft key to complete the blind transfer.

Attended Transfer

When you are in a call,

1. Press  or **Transfer** soft key, the current call will be holding.
2. Enter the number you want to transfer to.
1. Press **Send** soft key.
2. After the second call established, press  or **Transfer** soft key to complete the attended transfer.

Semi-Attended Transfer

When you are in a call,

1. Press  or **Transfer** soft key, the current call will be holding.

2. Enter the number you want to transfer to.
3. Press **Send** soft key.
4. When you hear the ringback tone, press  or **Transfer** soft key to complete the semi-attended transfer.

BLF Transfer

This feature controls the operation when you press the BLF key during a call. There are three modes:

- Attended Transfer
- Blind Transfer
- New Call

To set this feature, enter **Setting** → **Features** → **Transfer Settings** → **Transfer Mode via DSSkey**.

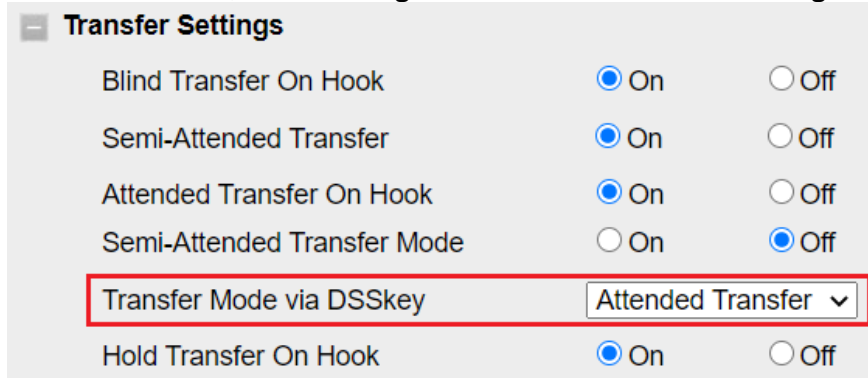

Transfer Settings

Blind Transfer On Hook	<input checked="" type="radio"/> On	<input type="radio"/> Off
Semi-Attended Transfer	<input checked="" type="radio"/> On	<input type="radio"/> Off
Attended Transfer On Hook	<input checked="" type="radio"/> On	<input type="radio"/> Off
Semi-Attended Transfer Mode	<input type="radio"/> On	<input checked="" type="radio"/> Off
Transfer Mode via DSSkey	Attended Transfer ▾	
Hold Transfer On Hook	<input checked="" type="radio"/> On	<input type="radio"/> Off

Relates to [BLF](#)

Override Transfer On Hook:

There are two calls at the same time, and one is in talking, another one is on held.

This feature allows you to transfer the current talking call to the held call by hanging up the handset.

How to configure

1. Log into webpage, **Setting** → **Features** → **Transfer Settings** → **Override Transfer On Hook**.
2. Switch the option to On.
3. In the same webpage, **Setting** → **Features** → **Transfer Settings** → **Attended Transfer On Hook**.
4. Switch the option to On.

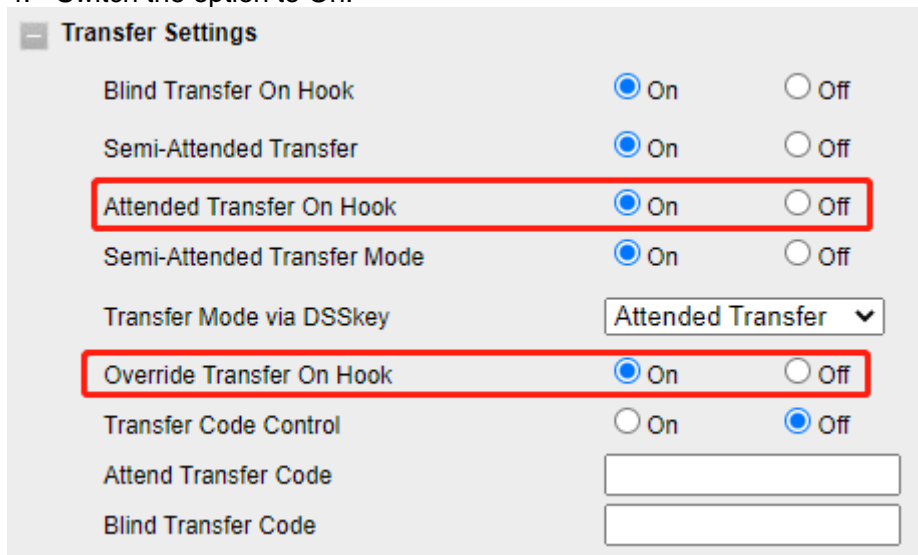

Transfer Settings

Blind Transfer On Hook	<input checked="" type="radio"/> On	<input type="radio"/> Off
Semi-Attended Transfer	<input checked="" type="radio"/> On	<input type="radio"/> Off
Attended Transfer On Hook	<input checked="" type="radio"/> On	<input type="radio"/> Off
Semi-Attended Transfer Mode	<input checked="" type="radio"/> On	<input type="radio"/> Off
Transfer Mode via DSSkey	Attended Transfer ▾	
Override Transfer On Hook	<input checked="" type="radio"/> On	<input type="radio"/> Off
Transfer Code Control	<input type="radio"/> On	<input checked="" type="radio"/> Off
Attend Transfer Code	<input type="text"/>	
Blind Transfer Code	<input type="text"/>	

How to use

1. A enables the Override Transfer On Hook feature.
2. During the conversation with B, A presses the Hold soft key and establishes a new call with C.
3. A hung up the handset.
4. The call will transfer to C and B.

Three Way Call Release Type:

This feature allows the participants of a local conference to keep talking when the chairman leave.

How to configure

1. The chairman should login webpage, **Setting → Preference → Three Way Call Release Type → Transfer**.

How to use

1. There is a 3-way conference.
2. The chairman press **EndCall** to exit the conference.
3. The two participants can continue to talk.

Three Way Call Release Type

Transfer Release Trigger

This option defines the time when the phone sends BYE to the server to release the transferred call.

How to configure

Log into webpage, **Profile → Basic → Transfer Release Trigger**.

1. NOTIFY with 200OK

After receiving REFER request send by phone, the server will send NOTIFY to the phone, and the phone response 200 OK, this is the trigger for the phone to release the call.

2. 2xx response of REFER

The phone will not release the call until it receives a 2xx response from the server to the phone's REFER request.

3. BYE for the call

The phone will not release the call until receiving BYE from the server.

Transfer Release Trigger:

Call Conference

This IP Phone supports up to 5-way conference.

5-way conference

1. Assuming that call party **A** and **B** are in conversation. **A** want to bring **C**, **D** and **E** in a conference
2. **A** press the Conf soft key, the call is placed on hold.
3. **A** enter the number of **C** and then press Send soft key or .
4. **C** answer the call.
5. **A** press the Conf soft key, then **A**, **B** and **C** are now in a conference. (and now this is **3-way conference**)
6. **A** press the Conf soft key, the current 3-way conference is placed on hold.
7. **A** enter the number of **D** and then press Send soft key or .
8. **D** answer the call.
9. **A** press the Conf soft key, then **A**, **B**, **C** and **D** are now in a conference. (and now this is **4-way conference**)
10. **A** press the Conf soft key, the current 4-way conference is placed on hold.
11. **A** enter the number of **E** and then press Send soft key or .
12. **E** answer the call.
13. **A** press the Conf soft key, then **A**, **B**, **C**, **D** and **E** are now in a conference. (and now this is **5-way conference**)
14. **A** end the call; the conference is finished.

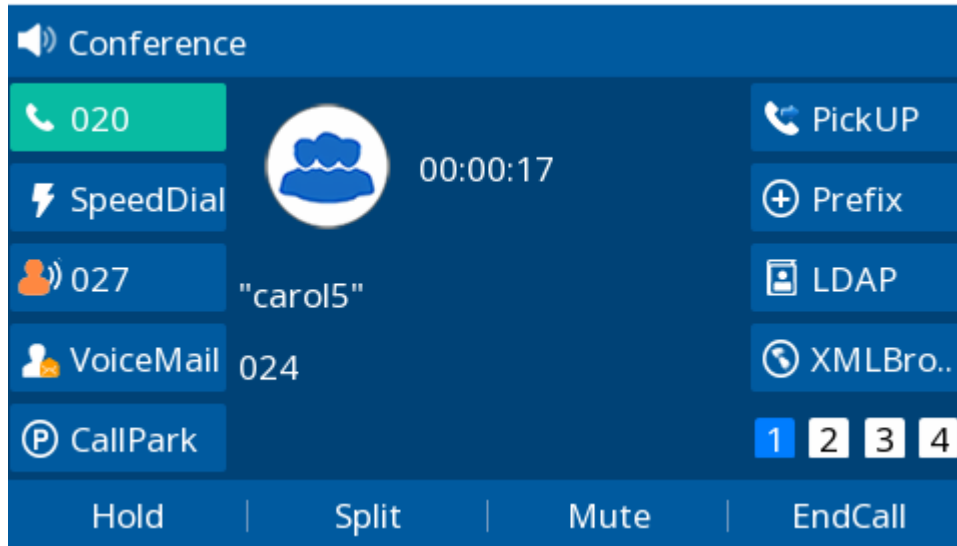

Note:

1. If **C** does not answer the call, **A** can back to continue the conversation with **B**;
2. Once **A** hangs up the call, the conference is ended, while if **B** or **C** drops the call, **A&C** or **A&B** continues the conversation.
3. The conference feature is not available on all servers. For more information, contact your system administrator.
4. To realize the 5-way conference, the line should be all available.

Call Forward

This phone supports static forward (always forward, busy forward and no answer forward) and dynamic forward.

To configure static forward

To configure always forward via Phone interface:

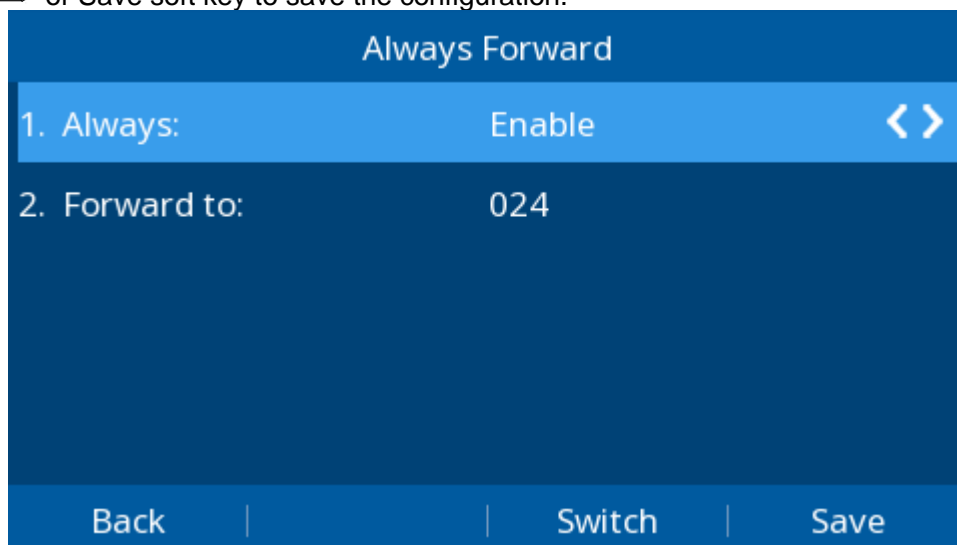

With this feature, all incoming calls will forward immediately to configured number.

1. Press Menu→ Features→ Forward→ Always.
2. Press and to select the Enable choice.
3. Enter the Forward to number.
4. Press or Save soft key to save the configuration.



To configure busy forward via Phone interface:

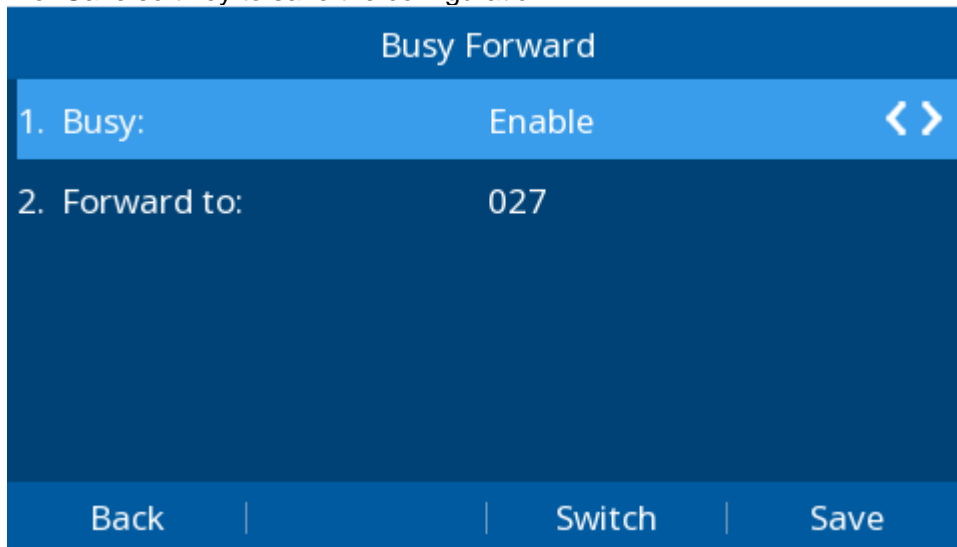

With this feature, the incoming calls are immediately forwarded if the phone is busy.

1. Press Menu→ Features→ Forward→ Busy.
2. Press  and  to select the Enable choice.
3. Enter the Forward to number.
4. Press  or Save soft key to save the configuration.





To configure no answer forward via Phone interface:

No Answer Forward: Incoming calls are forwarded if not answered after some time.

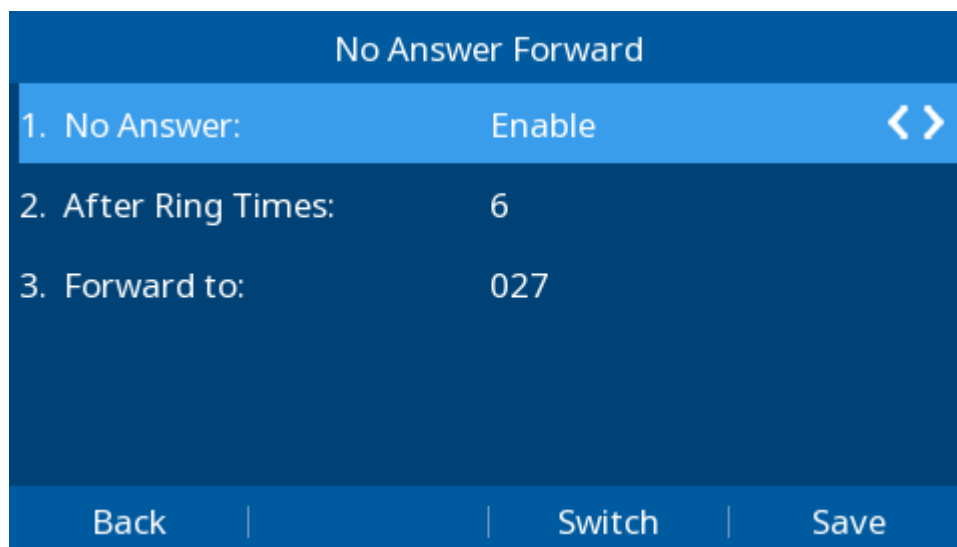
1. Press Menu→ Features→ Forward→ No Answer.
2. Press  and  to select the Enable choice
3. Enter the Forward To number and After Ring Times.



4. Press  or Save soft key to save the configuration.

When the Forward feature is enabled, the Icon  will display on Top of the LCD.

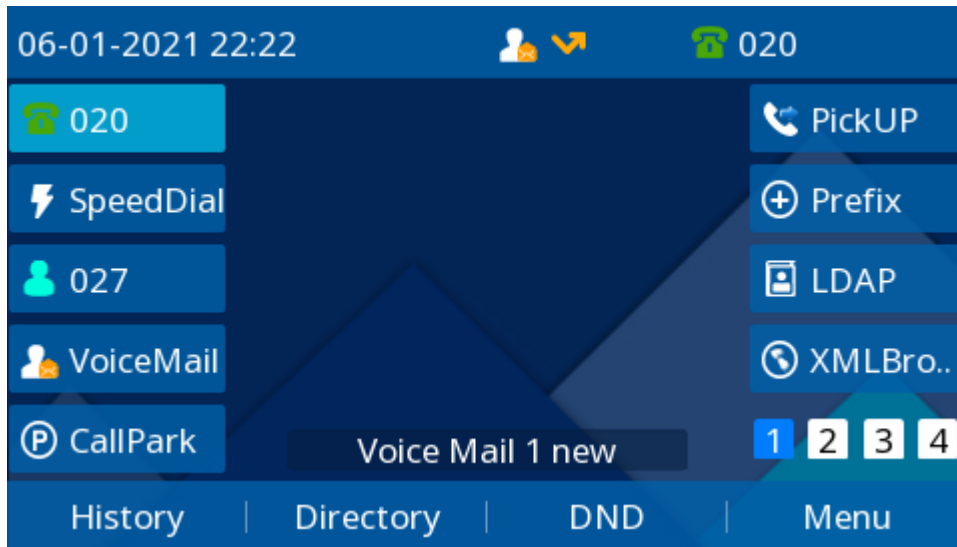



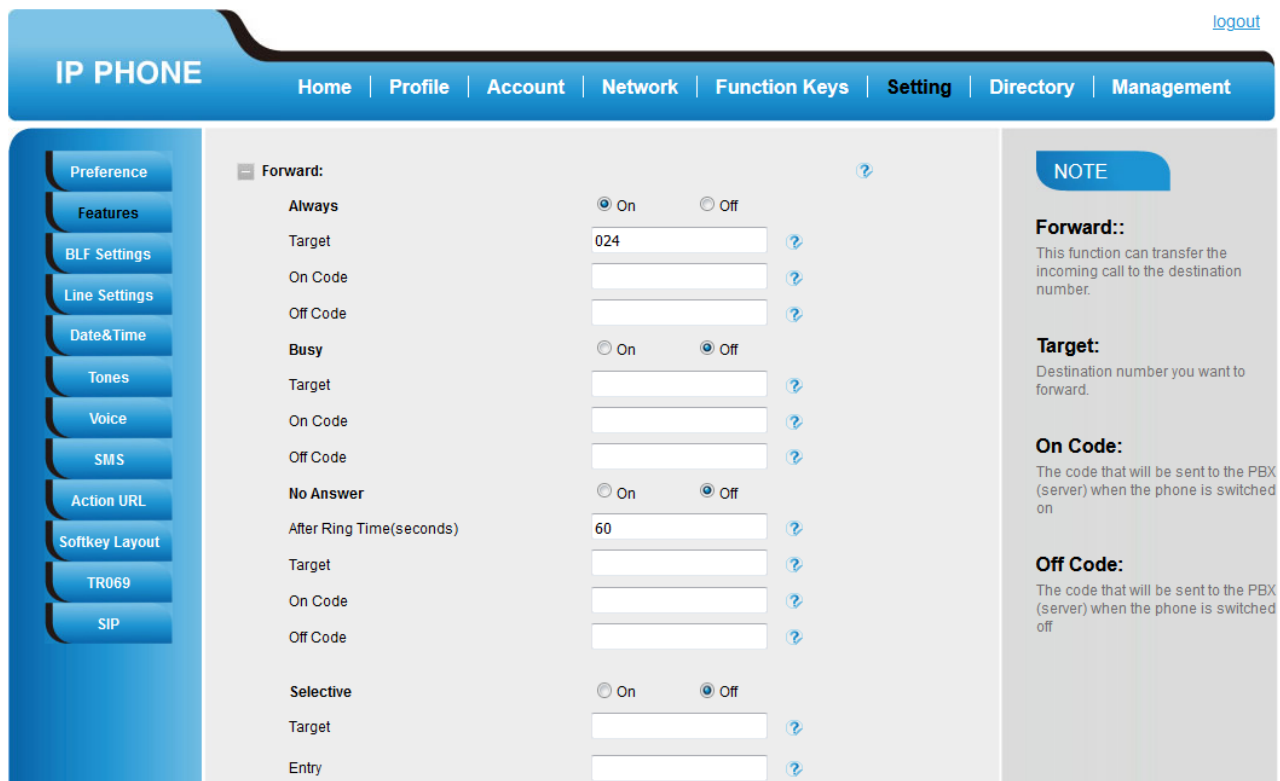

To configure Forward via Web interface

1. Setting→ Features
2. Click On for the Always/Busy/No Answer
3. Fill in the Target number.
4. Fill in the After Ring Time.
5. Fill in the On Code and Off Code (optional).
6. Click to save the configuration.

Note: If both DND and busy forward are activated on the phone, call will be forwarded to the configured destination number.



To cancel the forward feature via Phone interface

1. Option 1: To press the  key to disable the forward feature.
2. Option 2: Press Menu→ Features→ Forward→ Always/Busy/No Answer
 - a. Press  and  to select the Disable choice
 - b. Press  or Save soft key to save the configuration.

To cancel the forward feature via Web interface

1. Setting→ Features
2. Click Off for the Always/Busy/No Answer
3. Click to save the configuration.

To configure dynamic forward

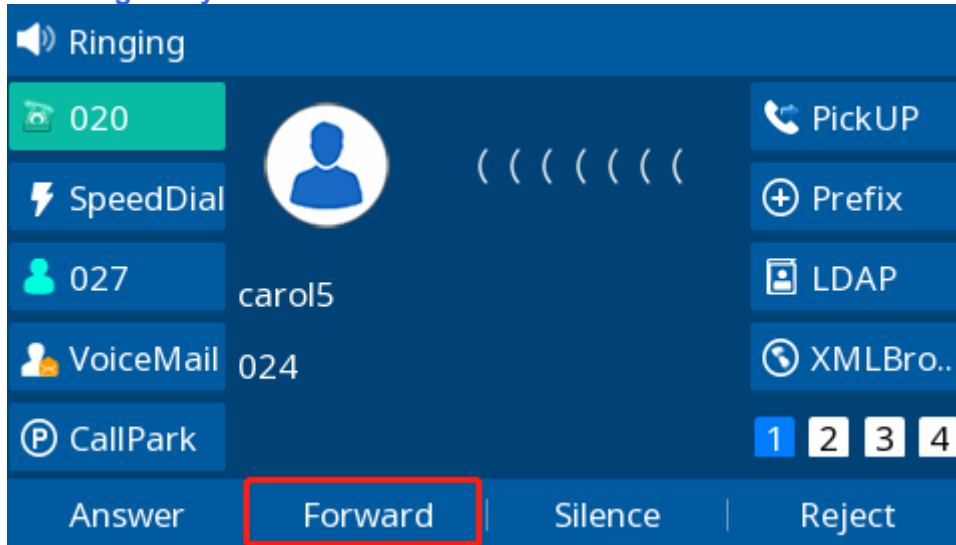

Forward an incoming call during the ringing.

1. When the phone is ringing, press Forward soft key.
2. Enter the forward number or select the desired number from Directory soft key (Precondition: local directory has one or more contacts).
3. Press or press the Send soft key, then the call is forwarded.

Note:

1. If the Programmable Key or line key is set as BLF, when an incoming call ringing, press this BLF key directly to realize the dynamic forward.
2. You can choose a desired forward number from the Directory when you press the Forward key.

Call Return

This feature allows you to dial the last phone call you received.

To configure the Call Return via Phone interface

1. Press Menu→ Features→ Function Keys→ Line Keys as Function Keys→ Line Key2(for example)
2. Press and key to select the Call Return in the Type field.
3. Press or Save soft key to save the configuration.

To configure the Call Return via Web interface

1. Click Function Keys→ Line Key.
2. Select the desired Line Key and select Call Return in the Type field.
3. Click to save the configuration.

Line	Type	Mode	Value	Label	Account	Extension
Key1	Line	Default		243	Account 1	
Key2	Call Return	Default			Account 1	

Call Waiting Tone

To enable the Call Waiting and Call Waiting Tone via Web interface

1. Click Setting→ Features
2. Select Call Waiting: On and Call Waiting Tone: On

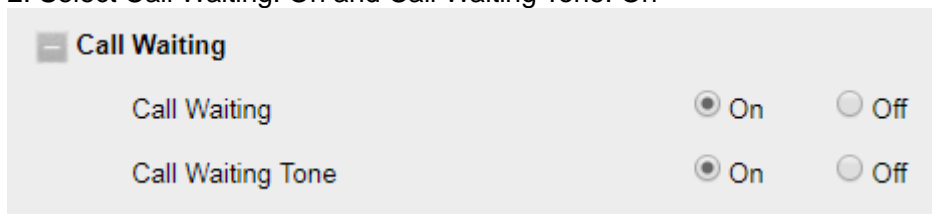

<input checked="" type="checkbox"/> Call Waiting	<input checked="" type="radio"/> On	<input type="radio"/> Off
<input checked="" type="checkbox"/> Call Waiting Tone	<input checked="" type="radio"/> On	<input type="radio"/> Off

To Change the Call Waiting Tone time via Web interface

1. Click Setting→ Tones

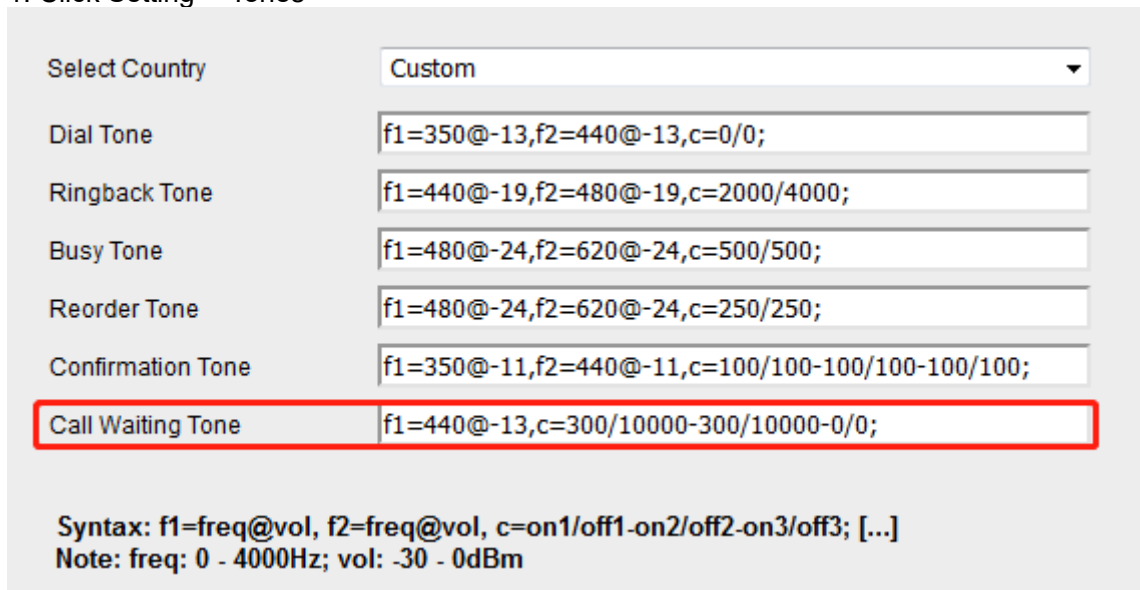

Select Country	Custom
Dial Tone	f1=350@-13,f2=440@-13,c=0/0;
Ringback Tone	f1=440@-19,f2=480@-19,c=2000/4000;
Busy Tone	f1=480@-24,f2=620@-24,c=500/500;
Reorder Tone	f1=480@-24,f2=620@-24,c=250/250;
Confirmation Tone	f1=350@-11,f2=440@-11,c=100/100-100/100-100/100;
Call Waiting Tone	f1=440@-13,c=300/10000-300/10000-0/0;

Syntax: f1=freq@vol, f2=freq@vol, c=on1/off1-on2/off2-on3/off3; [...]
Note: freq: 0 - 4000Hz; vol: -30 - 0dBm

2. Change the Tone Time as you want (for example 3s)

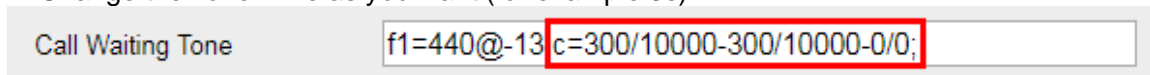



Call Waiting Tone	f1=440@-13,c=300/10000-300/10000-0/0;
-------------------	---------------------------------------

Hide Caller ID



Just enable the unknown/hidden caller feature, by enabling Anonymous call feature thereby the receiver won't be able to know who is calling them.

To configure anonymous call via Phone interface

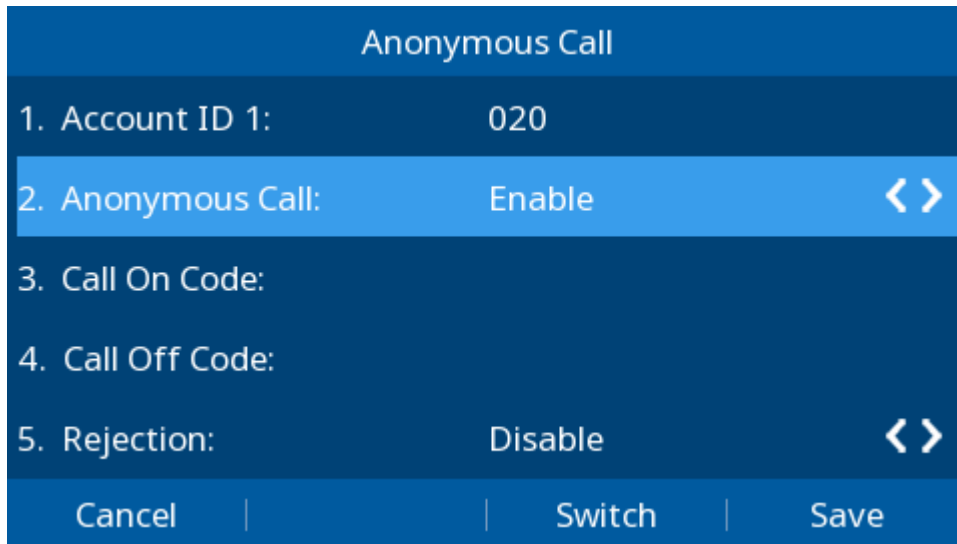
1. Press Menu→ Features→ Anonymous Call→Profile ID 2 (For example)
2. Press  and  to select the Enable choice in Anonymous Call filed.
3. Press  or Save soft key to save the configuration.





To cancel anonymous call feature via Phone interface

1. Press Menu→ Features→ Anonymous Call→Profile ID 2 (For example)
2. Press  and  key to select the Disable choice in Anonymous Call filed.
3. Press  or Save soft key to save the configuration.

Reject Anonymous



If you do not want to be disturb by anonymous calls, you can set the reject anonymous call feature, so you will not hear the unknown calls.

To configure rejecting anonymous call

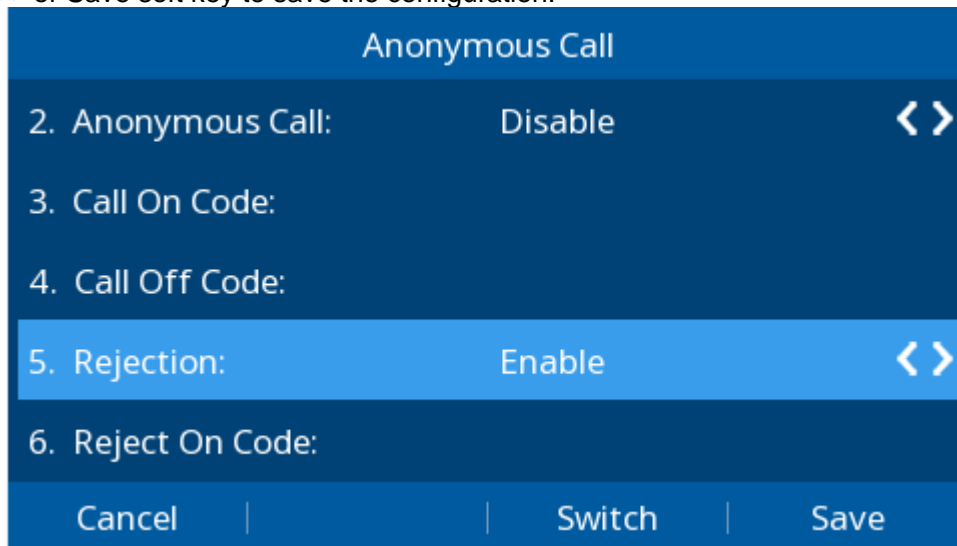
1. Press Menu→ Features→ Anonymous Call→Profile ID 2 (For example)
2. Press  and  key to select the Enable choice in Rejection filed.
3. Press  or Save soft key to save the configuration.



To cancel rejecting anonymous call



1. Press Menu→ Features→ Anonymous Call→Profile ID 2 (For example)
2. Press  and  key to select the Disable choice in Rejection filed.
3. Press  or Save soft key to save the configuration.

Call Mute

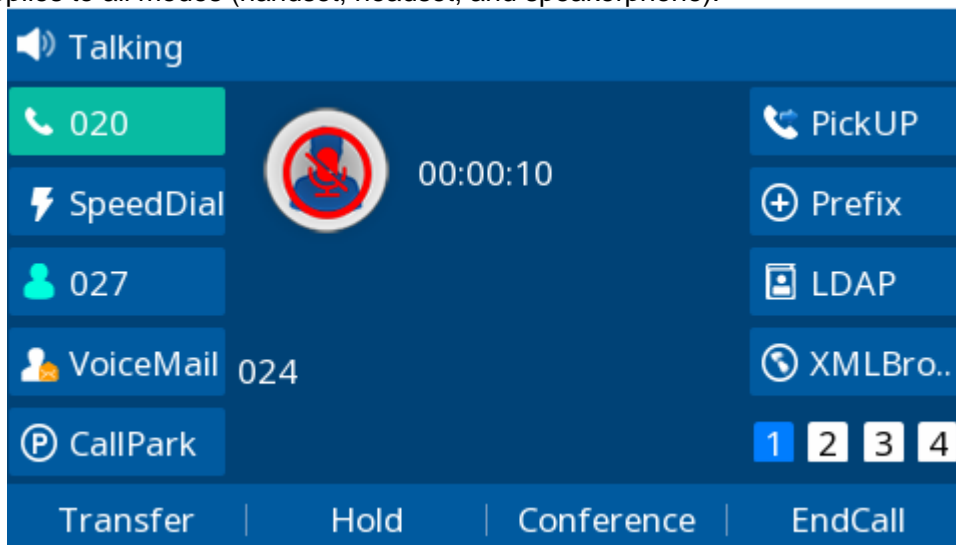
When you use the Mute feature, the other parties will not hear your voice while you can hear their voice. Call mute applies to all modes (handset, headset, and speakerphone).



To mute the call during a call (including a conference call)

1. Press the mute key , the LCD display .
2. To disable the mute function, press  again.

DND

When you use the DND feature, the phone is to reject all incoming calls automatically and you can see the DND icon  shown on the Top of the LCD on idle page.

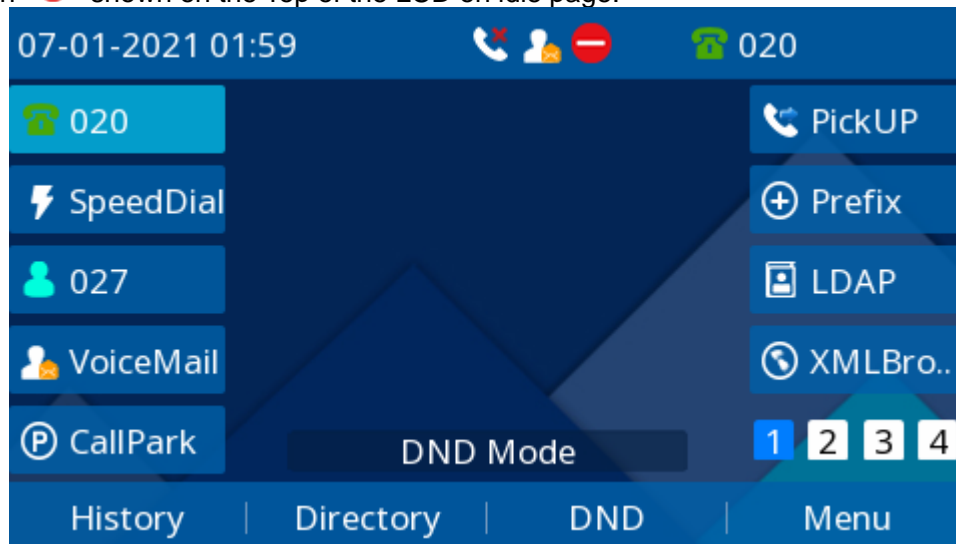

To enable DND feature via Phone interface:

Press the DND soft key when the phone is idle, and then  is shown on the LCD.

To disable DND feature via Phone interface:

Press the DND soft key again, and then there is no  on the LCD.

Hot Line

To configure Hot Line via Phone interface

1. Press Menu→ Features→ Hot Line
2. Enter the Number and HotLine Delay time (as present, we support off hook auto dial).
3. Press or Save soft key to save the configuration



The screenshot shows a 'Hot Line' configuration screen. At the top, it says 'Hot Line'. Below that, there are two input fields: '1. Number:' and '2. HotLine Delay:'. The 'Number' field is currently empty. At the bottom of the screen, there is a navigation bar with four buttons: 'Back', '123', 'Delete', and 'Save'.

To configure Hotline auto dial via Web interface

1. Setting→ Features.
2. Fill in the number in the Hotline Number and Hotline Time-out field.
3. Click to save the configuration.

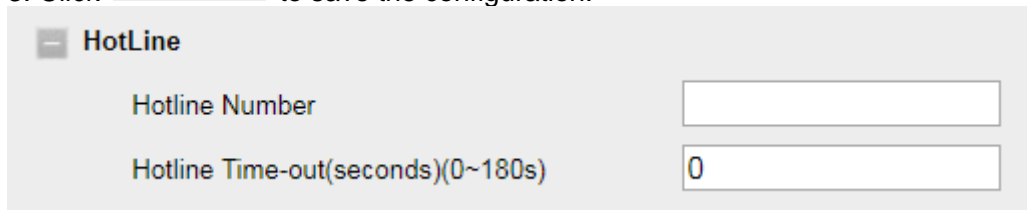

The screenshot shows a web interface for configuring 'HotLine'. It has a title 'HotLine' with a minus sign icon. There are two input fields: 'Hotline Number' and 'Hotline Time-out(seconds)(0~180s)'. The 'Hotline Time-out' field currently has the value '0'. There is a 'SaveSet' button to the right of the fields.

4. Delete the Hotline Number and save the configuration, then now the Hotline auto dial is cancelled.

Auto Redial

After setting this option, if the phone you are calling responds 486 Busy Here, the phone will prompt it with a busy tone (Busy Tone Timer (0~5s)), and then it will prompt Auto Redial, as shown in the figure.

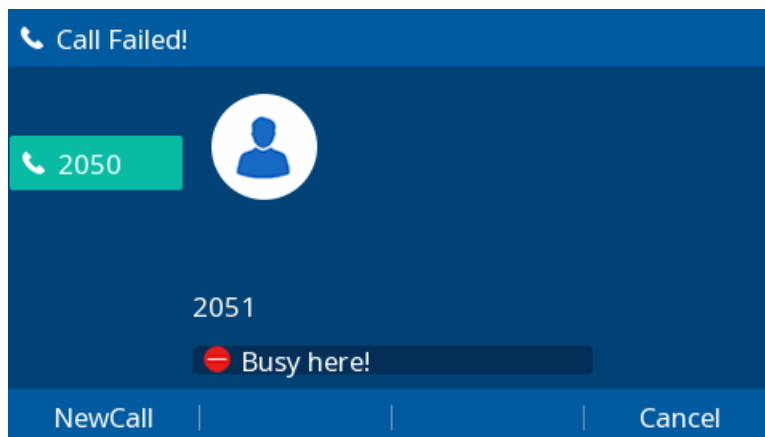

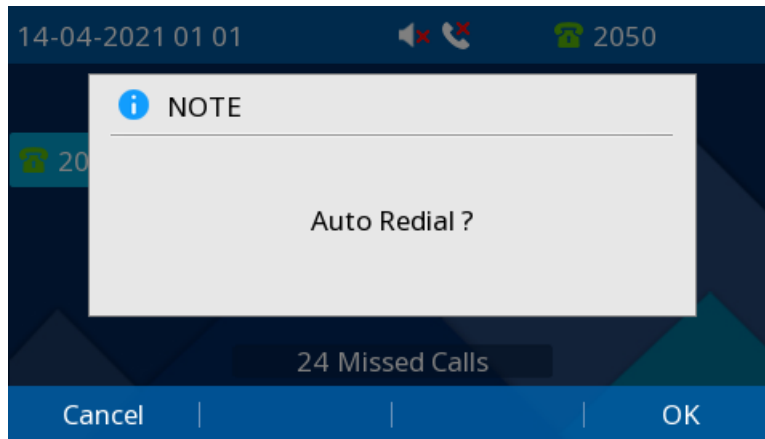

If you press OK, your LCD will prompt Auto Redial Interval and Auto Redial Times.

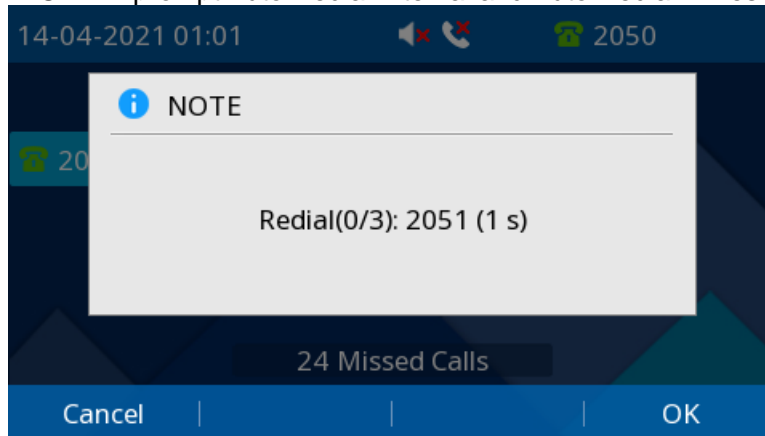

To configure Auto Redial via Web interface

1. Click Setting→ Features→ Auto Redial
2. Select On or Off for the Auto Redial.
3. Fill in the number 1~300 seconds for the Auto Redial Interval.
4. Fill in the number 1~300 times for the Auto Redial Times.
5. Click to save the configuration.

Auto Redial

Auto Redial On Off

Auto Redial Interval (1~300s)

Auto Redial Times (1~300)

Note:
If you do not want the Busy here prompt, please set Busy Tone Timer as 0. 0 means there is no busy tone.

Help center

The help center has two modes: software problem diagnosis and hardware diagnosis. The fault diagnosis mode is used to help technical support engineers collect information (such as phone logs and configurations) more conveniently for technical support and development engineers to analyze customer problems. Hardware diagnosis provides a user-friendly way to diagnose hardware problems.

4. Software problem diagnosis

To use the help center via Phone interface:

1. Press Menu
2. Press the keypad **##****

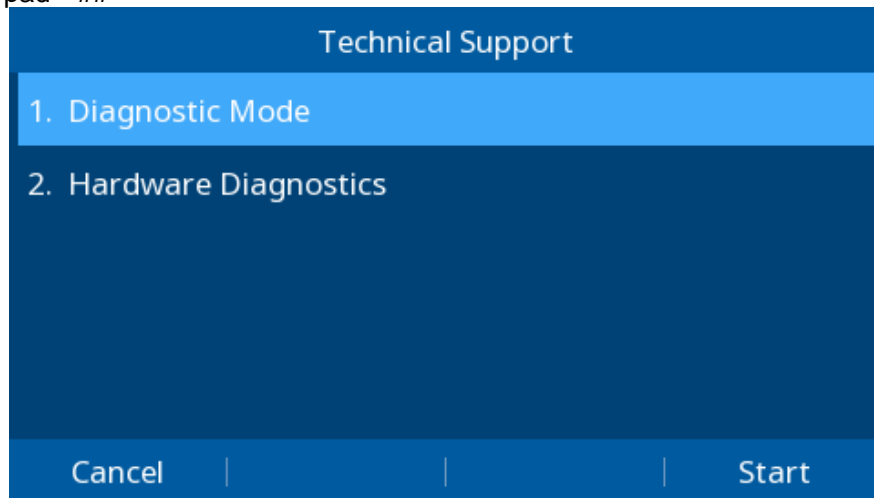

3. Press softkey Start
4. Press ok and start operation after the frame disappears
5. Enter the help center again
6. Select stop and the operation logs will be uploaded to the server

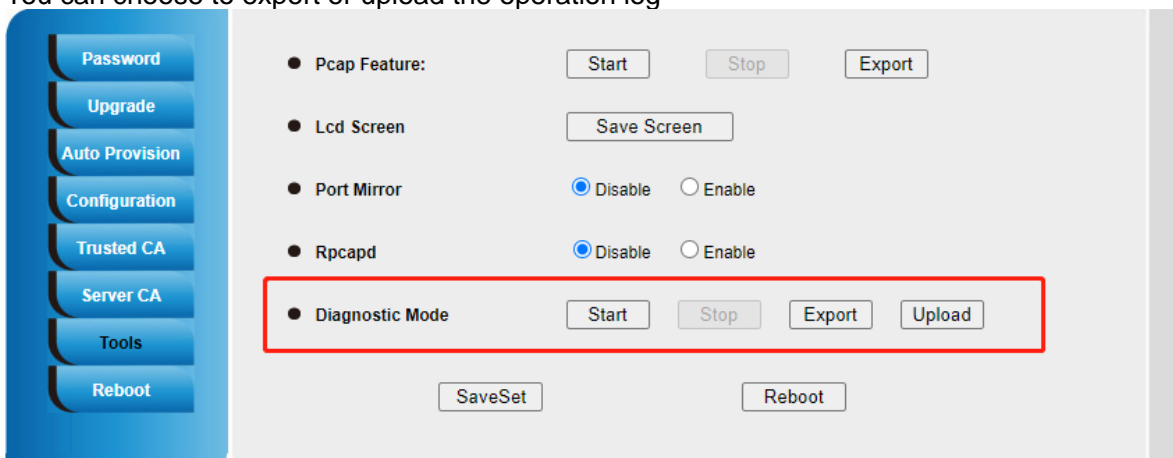

To use the help center via Web interface:

1. Click Management →Tools
2. Click Diagnostic Mode Start
3. Wait for a few seconds and perform the operation on the IP phone
4. Click stop
5. You can choose to export or upload the operation log



5. Hardware diagnosis

You can perform hardware diagnosis only via Phone interface

1. Press Menu
2. Press the keypad **##****
3. Press  and  to select Hardware diagnostics

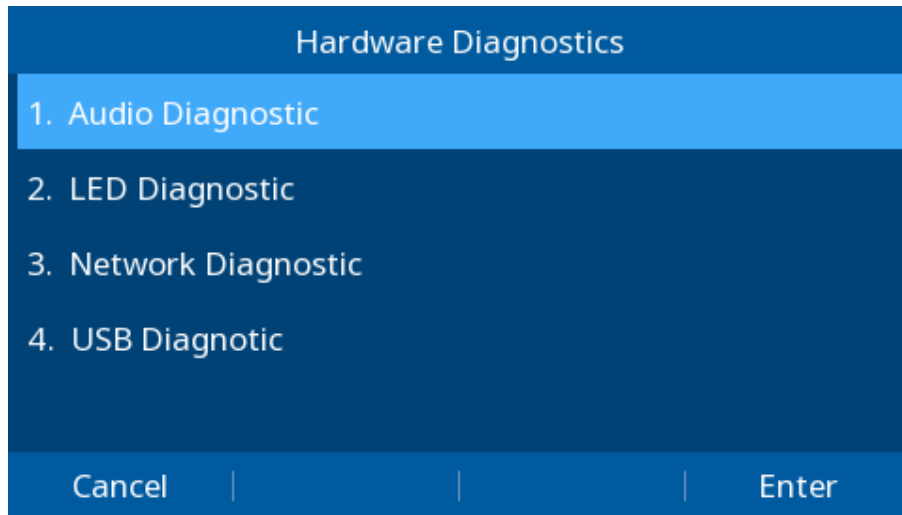

Audio Diagnostic:

1. Select Audio Diagnostic
2. The voice chip self-check is automatically performed after the page is displayed
3. Voice echo test Related tests are performed on the phone, and you can switch by speakerphone, handset and headset
4. Press finish and choose the result

If you choose abnormal, the phone will play an audio clip:

1. Press start
2. Check whether the sound is normal after playing.
3. If the sound is abnormal, the playback device is faulty; if the sound is normal, the radio device is faulty.

LED Diagnostic:

You can switch the Off, Green and Red states of all LED lights by the left and right keys.

Network Diagnostic:

You can choose WAN Port Status, LAN Port Status, Ping and Trace Route.

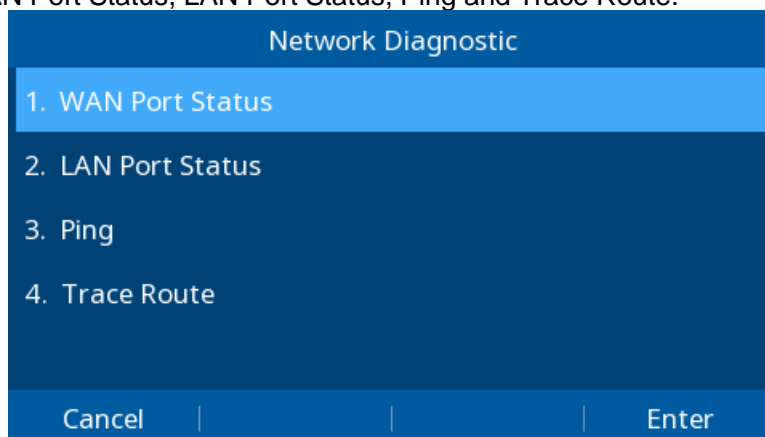

WAN Port Status:

The device checks itself and displays network information

LAN Port Status:

The device checks itself and displays network information

Ping:

The default detection is 8.8.8.8.

Press back and you can enter the IP address

TraceRoute:

The default detection is 8.8.8.8
Press back and you can enter the IP address

USB Diagnostic:

1. The device automatically checks the USB port status
2. Insert the USB as prompted
3. The device will further check whether the function is normal.

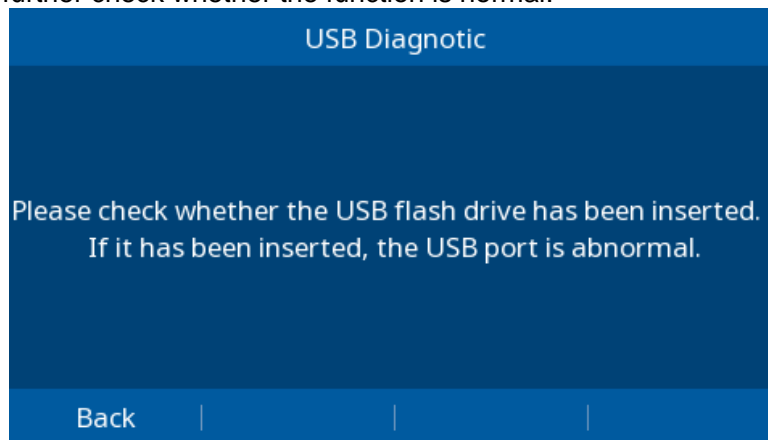



Diagnostics

With diagnostics function, you can troubleshoot network connectivity problems. Here you can use both Ping and Traceroute functions. You can enable the phone to detect the reachability of the connected wired or wireless network.

6. Ping

Ping is used to determine whether the local host can successfully exchange (send and receive) data packets with another host. Based on the returned information, it can be inferred whether the TCP/IP parameters are set correctly, whether the operation is normal, whether the network is smooth, etc.

How to use Ping function:

1. Press soft key Menu→Features
2. Press  and  to choose diagnostics
3. Enter Network→Ping
4. Fill in Ping IP or URL
5. Press soft key Start

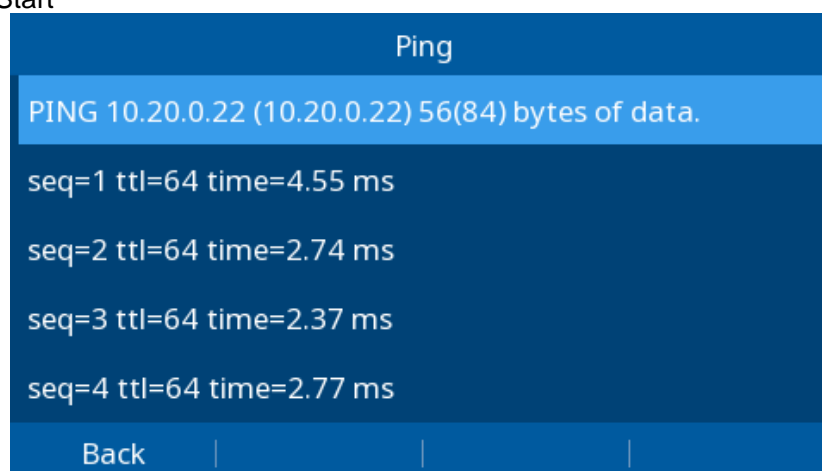

You can also use Ping via the web user interface:

1. Click Network→Diagnostics

2. Choose method Ping
3. Fill in IP Addr
4. Click

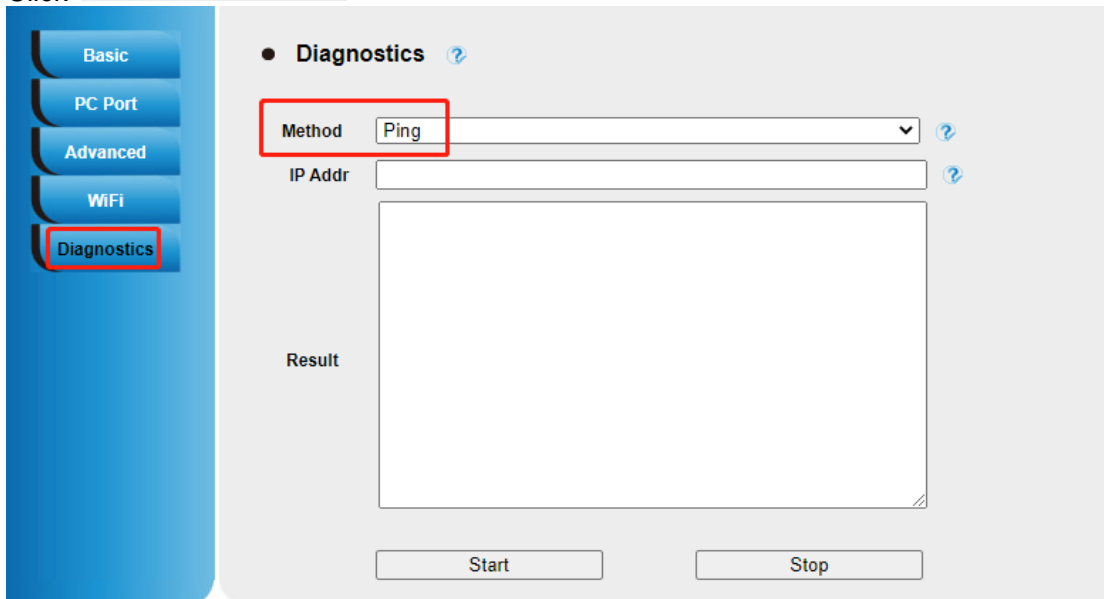

7. Traceroute

Traceroute measures how long it takes by sending small packets to the destination device until it returns. By default, traceroute tests each device on a path three times. The output results include the time (ms) of each test and the device name (if any) and its IP address.

How to use Traceroute function:

1. Press soft key Menu→Features
2. Press and to choose diagnostics
3. Enter Network→Trace Route
4. Fill in Tracert IP or URL
5. Press soft key Start

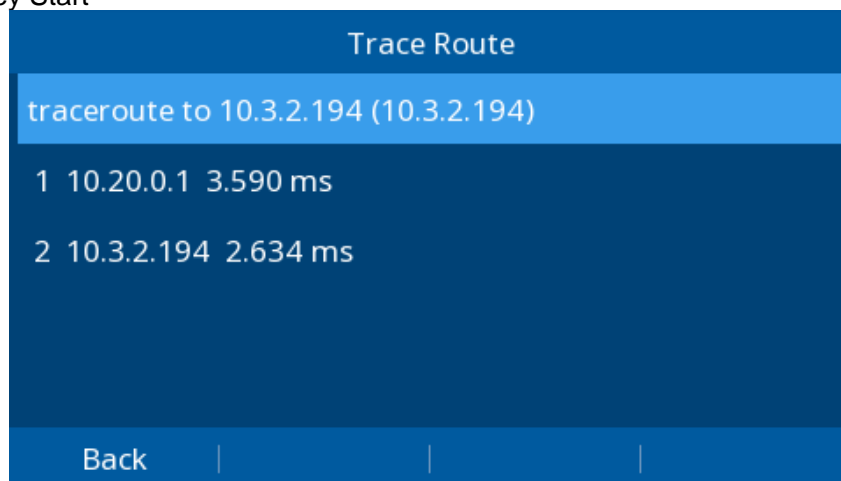

You can also use Traceroute via the web user interface:

1. Click Network→Diagnostics
2. Choose method Traceroute
3. Fill in IP Addr
4. Click and

Power Saving

The power saving feature is used to turn off the backlight to conserve energy. The phone enters power saving mode after it has been idle for a certain period of time. Image persistence may be caused on LCD if Power Saving is disabled.

Office Hour: The period of time you use the phone frequently. Time from 0 o'clock to 23 o'clock.

Idle Timeout: specify the period of time before the IP phone enters the power-saving mode.

You can specify the following three types of idle timeout

Office Hour Idle TimeOut: It's the time of phone waits in the idle state before the phone enters power saving mode during the office hours. (Integer from 1 to 960 minutes)

Off Hour Idle TimeOut: It's the time of phone waits in the idle state before the phone enters power saving mode during the non-office hours. (Integer from 1 to 10 minutes)

User Input Extension Idle TimeOut: It's the minimum time of phone waits in the idle state after using the phone before the phone enters power saving mode. (Integer from 1 to 30 minutes)

How to config your Power Saving mode:

You can enable or disable power saving and set the different idle timeout in the web user interface.

1. Click Setting→Power Saving

2. Click Enable

3. Fill in the Office Hour and Idle and Idle TimeOut Setting

4. Click

The screenshot shows the 'Power Saving' configuration page. On the left is a navigation menu with options: Preference, Features, BLF Settings, Line Settings, Date&Time, Tones, Voice, SMS, Action URL, Softkey layout, TR069, SIP, and Power Saving. The main content area is titled 'Power Saving' and has radio buttons for 'Disable' and 'Enable' (selected). Below this is the 'Office Hour' section with a help icon, showing time ranges for each day of the week: Monday (7-19), Tuesday (7-19), Wednesday (7-19), Thursday (7-19), Friday (7-19), Saturday (7-7), and Sunday (7-7). The 'Idle TimeOut Settings(minutes)' section includes three input fields: 'Office Hour Idle TimeOut' (960), 'Off Hour Idle TimeOut' (10), and 'User Input Extension Idle TimeOut' (10), each with a help icon. At the bottom are 'SaveSet' and 'Cancel' buttons.

Advanced Call Features

Call Pickup

With this feature, you can pick up the set line when it is ringing.

To configure Direct Pickup code via Web interface





1. Click Account→ Basic.

2. Select the desired account from the pull-down list of Account in the Account field.

3. Fill in the Direct Call Pickup Code.
4. Click to save the configuration.

Direct Call Pickup Code

To configure Direct Pickup feature via Phone interface

1. Press Menu→ Features→ Function Keys→ Line Keys as Function Keys→ Line Key2(for example)
2. Press  and  key to select the PickUP in the Type field.
3. Enter the targeted Number in the Value field.
4. Press  and  key to select the Account ID.
5. Press or Save soft key to save the configuration, then the selected Line Key will work as Direct Pickup.

To configure Direct Pickup feature via Web interface

1. Click Function Keys→ Line Key.
2. Select the wanted Line Key and set as Direct Pickup.
3. Enter the desired phone number in the Value field.
4. Select the Account
5. Click to save the configuration.

Line	Type	Mode	Value	Label	Account	Extension
Key1	Line	Default			Account 1	
Key2	Direct Pickup	Default	*20*137		Account 1	

Group Pickup





With this feature, you can pick up the specified group that you want incoming calls.

To configure Group Pickup code via Web interface

1. Click Account→ Basic.
2. Select the desired account from the pull-down list of Account in the Account field.
3. Fill in the Group Call Pickup Code
4. Click to save the configuration.

Group Call Pickup Code

To configure the Group Pickup via Phone interface

1. Press Menu→ Features→ Function Keys→ Line Keys as Function Keys→ Line Key2(for example)
2. Press  and  key to select the Group in the Type field.
3. Enter the targeted Number in the Value field.
4. Press  and  key to select the Account ID.
5. Press or Save soft key to save the configuration

To configure the Group Pickup via Web interface

1. Click Function Keys→ Line Key.
2. Select the desired Line Key and select Group Pickup in the Type field.
3. Enter the desired phone number in the Value field.
4. Select the Account
5. Click to save the configuration.

Line	Type	Mode	Value	Label	Account	Extension
Key1	Line	Default		243	Account 1	
Key2	Group Pickup	Default	8038		Account 2	

Call Park

With this feature, you can put a call on hold and continue the conversation from another phone.

To configure the Call Park via Phone interface

1. Press Menu→ Features→ Function Keys→ Line Keys as Function Keys→ Line Key2(for example)
2. Press and or press Switch soft key to select the Call Park in the Type field.
3. Enter the call park code in the Value field
4. Press and key to select the Account ID.
5. Press or Save soft key to save the configuration.

To configure the Call Park via Web interface

1. Click Function Keys→ Line Key.
2. Select the desired Line Key and select Call Park in the Type field.
3. Enter the call park code in the Value field.
4. Select the Account.
5. Click the button to save the configuration.

Line	Type	Mode	Value	Label	Account	Extension
Key1	Line	Default		088	Auto	
Key2	Call Park	Default	SP10		Account 1	

Busy Lamp Field (BLF)

You can use the BLF (Busy Lamp Field) feature to monitor a specific extension number whether the extension is busy or free.

1. When the extension you are monitoring is idle, the light is steady green.
2. When the monitored extension is ringing, the light is blinking red, press the BLF key to pick the phone up directly.
3. When the monitored extension is calling or in a conversation, the light is steady red.

To configure a BLF key via Phone interface

1. Press Menu→ Features→ Function Keys→ Line Keys as Function Keys→ Line Key2(for example).
2. Press and key to select the BLF in the Type field.
3. Enter the targeted Number in the Value field.
4. Press and key to select the Account ID.
5. Enter the Pickup Code.
6. Press or Save soft key to save the configuration.

To configure a BLF key via Web interface

1. Click Function Keys→ Line Key.

2. Select the desired Line Key and select BLF in the Type field.
3. Enter the monitored phone number in the Value field.
4. Select the Account
5. Fill in the Extension.
6. Click to save the configuration.

Line	Type	Mode	Value	Label	Account	Extension
Key1	Line	Default		243	Account 1	
Key2	BLF	Default	245		Account 1	

Note:

This feature is not available on all servers. For more information, contact your system administrator.

After setting the BLF key, do not need to reboot the phone.

Visual Alert for BLF Pickup

If this option is on, when you use the BLF feature to monitor a specific phone whether it is busy or free, you can see this message on the LCD, as shown in the following figure.

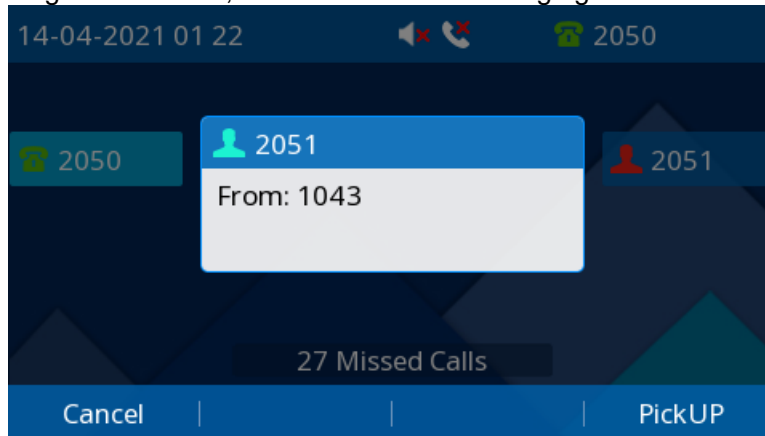

To configure Visual Alert for BLF Pickup via Web interface

1. Click Setting→ Features→ Call Pickup→ Visual Alert for BLF Pickup
2. Select Enable or Disable for Visual Alert for BLF Pickup.
3. Click to save the configuration.

Call Pickup

Call Pickup Mode

Direct Call Pickup

Direct Call Pickup Code

Group Call Pickup

Group Call Pickup Code

Visual Alert for BLF Pickup

Audio Alert for BLF Pickup

To configure BLF via Web interface

1. Click Function Keys→ Line key
2. Select the desired Line.
3. Type selection as BLF.

4. Fill in the required BLF value.
5. Fill in the required pickup code for the extension number.
6. Click to save the configuration.

Line	Type	Mode	Value	Label	Account	Extension
Key1	Line	Default			Account 2	
Key2	BLF	Default	1025		Account 2	*04

Audio Alert for BLF Pickup

If this option is on, when you use the BLF feature to monitor a specific phone whether it is busy or free, you can hear beep.

To configure Audio Alert for BLF Pickup via Web interface

1. Click Setting→ Features→ Call Pickup→ Audio Alert for BLF Pickup
2. Select Enable or Disable for Audio Alert for BLF Pickup.
3. Click to save the configuration.

Call Pickup

Call Pickup Mode

Direct Call Pickup

Direct Call Pickup Code

Group Call Pickup

Group Call Pickup Code

Visual Alert for BLF Pickup

Audio Alert for BLF Pickup

BLF List

To configure BLF List via Web interface:

1. Login and click Account→ Basic
2. Select the desired account from the pull-down list of Account in the Account field.
3. Fill in the Eventlist BLF URL.

Eventlist BLF URL

4. Click Profile→ Advanced
5. Select the desired profile from the pull-down list of Profile in the Profile field.
6. Select the SIP Server Type

SIP Server Type

7. Click to save the configuration.
8. To configure BLF List Keys
 - 8.1 Click Function Keys→ Line Key
 - 8.2 Select the desired Line Key and select the BLF List in the Type field.
 - 8.3 Select the Account
 - 8.4 Click to save the configuration.

Line	Type	Mode	Value	Label	Account	Extension
Key1	Line	Default		243	Account 1	
Key2	BLF List	Default			Account 1	

Share Line

IP Phone supports “Shared Call Appearance” by Broadsoft and XCast standard. This feature allows members of the SCA group to shared SIP lines and provides status monitoring (idle, active, progressing, hold) of the shared line. When there is an incoming call designated for the SCA group, all the members of the group will be notified of an incoming call and will be able to answer the call from the phone with the SCA extension registered in the group.

All the users that belong to the same SCA group will be notified by visual indicator when a user seizes the line and places an outgoing call, and all the users of this group will not be able to seize the line until the line goes back to an idle state or when the call is placed on hold (with the exception of when multiple call appearances are enabled on the server side).

In the middle of the conversation, there are two types of hold: Public Hold and Private Hold. When a member of the group places the call on public hold, the other users of the SCA group will be notified of this by the red-flashing button and they will be able to resume the call from their phone by pressing the line button. However, if this call is placed on private-hold, no other member of the SCA group will be able to resume that call.

To enable shared call appearance, the user would need to register the shared line account on the phone. In addition, they would need to navigate to “Account”→ “Basic” and “Profile”→ “Advanced” on the webpage and set the line to “Shared Line” and “SIP Server Type”, and configure the line key or Line Key as “Line” type with the desired account on webpage or LCD. If the user requires more shared call appearances, the user can configure multiple line keys (Function Keys→ Line Key) to be “Line” type associated with the account.

This feature is very useful in the boss and secretary scenario. For example, the secretary can share the boss' extension number on her phone. When there is an incoming call to the extension number of the boss, both the phones of the boss and the secretary will ring simultaneously. Either the boss or the secretary can answer the call. Calls on shared line can be placed on hold or barged in.

To enable share line via Web interface

1. Click Account→ Basic
2. Select the desired account from the pull-down list of Account in the Account field.
3. Select SCA for the Shared Line.

Shared Line	Disable
-------------	---------



4. Click Profile→ Advanced
5. Select the desired profile from the pull-down list of Profile in the Profile field.
6. Select the SIP Server Type.

SIP Server Type	BroadSoft
-----------------	-----------

7. Click to save the configuration.

To configure Line key via Phone interface

1. Press Menu→ Features→ Function Keys→ Line keys as Function Keys→ Line Key1(for example)

2. Press  and  key to select the Line in the Type field.
3. Select the Account ID.

4. Press  or Save soft key to save the configuration. Then the selected Line Key will work as Line.

To configure Line key via Web interface

1. Click Function Keys→ Line Key.
2. Select the wanted Line Key and set as Line.
3. Select the Account.
4. Click the button to save the configuration.

Line	Type	Mode	Value	Label	Account	Extension
Key1	Line	Default		243	Account 1	
Key2	N/A	Default			Account 1	



Note:

This feature is not available on all servers. For more information, contact your system administrator.

Intercom

When use the intercom feature, you can quickly get access connect to the configured one.

To configure Intercom feature via Phone interface

1. Press Menu→ Features→ Function Keys→ Line Keys as Function Keys→ Line Key2(for example)
 2. Press  and  key to select the Intercom in the Type field.
 3. Enter the intercom codes followed by desired number.
 4. Select the Account ID.
 5. Press  or Save soft key to save the configuration.
- Then the selected Line Key will work as Intercom.

To configure Intercom feature via Web interface

1. Click Function Keys→ Line Key.
2. Select the wanted Line Key and set as Intercom.
3. Enter the intercom codes followed by desired number in the Value field.
4. Select the Account.
5. Click the button to save the configuration.

Line	Type	Mode	Value	Label	Account	Extension
Key1	Line	Default		088	Auto	
Key2	Intercom	Default	*11012		Account 1	

If you want to achieve the Intercom feature, you must enable the “Allow Auto Answer by Call-Info”

1. Login webpage, and click Profile→ Advanced
2. Select the desired profile from the pull-down list of Profile in the Profile field.
3. Select Yes for the “Allow Auto Answer By Call-Info”
4. Click the button to save the configuration.

Allow Auto Answer By Call-Info No Yes

Note:

This feature is not available on all servers. For more information, contact your system administrator.

Intercom Barge

If this option is enabled, when there is an active call and an incoming intercom call arrives, the previous

call will be put on hold and the intercom call will be answered.

1. Login webpage, and click Setting→ Preference
2. Set On or Off for Intercom Barge.
3. Click for the setting.

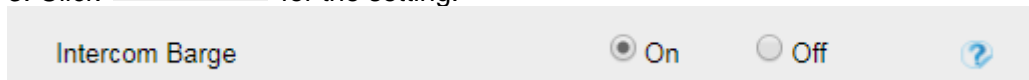

Note:

This feature is not available on all servers. For more information, contact your system administrator.

Short Message Service (SMS)

8. Send SMS

To send SMS via Web interface

1. Click Setting→ SMS
2. Select the Account (from which account the SMS sent)
3. Enter the target Number
4. Input the content of SMS and click .

To send SMS via Phone interface:

1. Click Menu→ Messages→ SMS→ Set SMS
2. Enter the contents in the white field.
3. Press the Send button.
4. Select the account in the From field (from which account the SMS sent)
5. Enter the target number in the To field (to which account the number sent)
6. Press the Send button.

9. Set SMS Line Key

To configure the SMS via Phone interface

1. Press Menu→ Features→ Function Keys→ Line Keys as Function Keys→ Line Key2(for example)
2. Press and key to select the SMS in the Type field.

3. Press  or Save soft key to save the configuration.

To configure the SMS via Web interface

1. Click Function Keys→ Line Key.
2. Select the desired Line Key and select SMS in the Type field.
3. Click  to save the configuration.

Line	Type	Mode	Value	Label	Account	Extension
Key1	Line	Default		243	Account 1	
Key2	SMS	Default			Account 1	

Voice Mail

This phone supports voicemail, and when there is a message, you can press the message key  to listen to voice Mail. Text Notify will be displayed on the LCD of the phone.

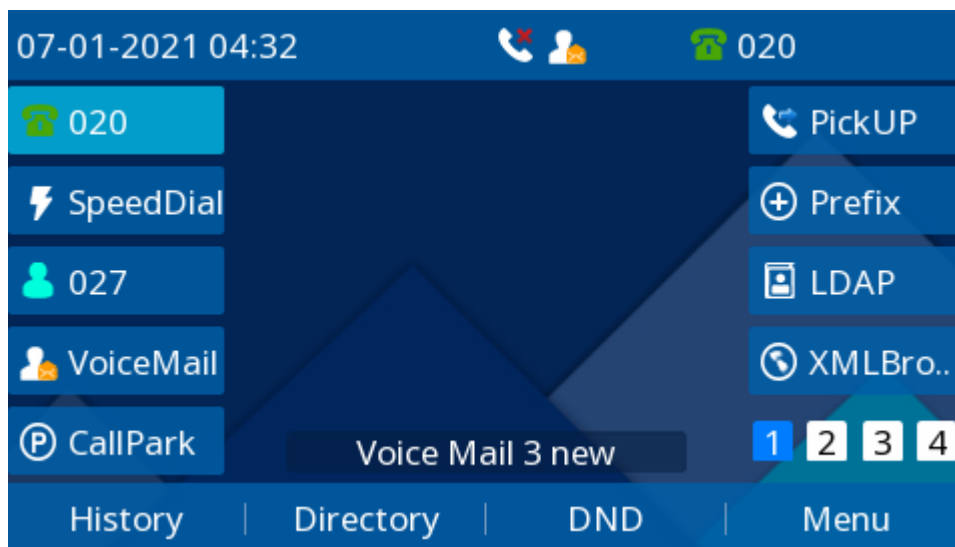

To configure the Voice Mail feature via Phone interface:

1. Press Menu→ Messages→ Voice Mail→ Set Voice Mail.
2. Enter the Account No.
3. Press  or Save soft key to save the configuration.





To configure the Voice Mail feature via Web interface:

1. Click Account→ Basic.
2. Select the desired account from the pull-down list of Account in the Account field.
3. Fill in the Voice Mail UserID.
4. Click  to save the configuration.

Voice Mail UserID

To configure a Voice Mail key via Phone interface:

1. Press Menu→ Features→ Function Keys→ Line Keys as Function Keys→ Line Key2(for example).

2. Press  and  key to select the Voice Mail in the Type field.
3. Enter the targeted feature codes in the Value field.
4. Press  and  key to select the Account ID.
5. Press  or Save soft key to save the configuration.

To configure a Voice Mail Key via Web interface:

1. Click Function Keys→ Line Key.
2. Select the wanted Line Key and set as Voice Mail.
3. Enter the desired voicemail feature codes in the Value field.
4. Select the Account.
5. Click  to save the configuration.

Line	Type	Mode	Value	Label	Account	Extension
Key1	Line	Default		243	Account 1	
Key2	Voice Mail	Default	*97		Account 1	

To leave a voice mail:

You can leave a voice mail when the receiver is busy or its inconvenient for them to answer the call. Follow the voice prompt from the system server to leave a voice mail, and then hang up.

To listen to voice mails:

When the phone interface prompts receiving new voice mail's icon, the power indicator LED flashes red (Setting→ Preference→ LED Status Setting: Voice Message Status: Yes) and the voice message button flashes green.

1. Pressing  or the targeted Line Key to dial out the voice mail access code.
2. Follow the voice prompt to listen to voice mail.

To view the voicemail via Phone interface:

Press Menu→ Messages→ Voice Mail→ View Voice Mail.

The LCD screen displays the amount of new and old voice mails.

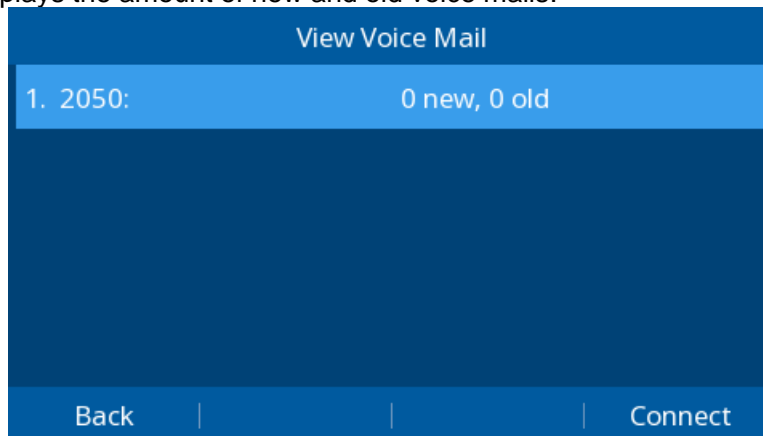

Note:

1. This feature is not available on all servers. For more information, contact your system administrator.
2. Before listening to voice mails, make sure the voice mail access code has been configured.
3. When all new voice mails are retrieved, the power indicator LED, voice mail indicator LED and targeted Line Key LED will go out.

Using the Hot Desking



10. Hot Desking

Hot Desking originates from the definition of being the temporary physical occupant of a workstation or surface by a particular employee. A primary motivation for Hot Desking is cost reduction. This feature is regularly used in places where all employees are not in the office at the same time, or not in the office for a very long time, which means their personal offices are often vacant, consuming valuable space and resources.

You can use Hot Desking on the IP phone to logout the existing accounts and then log in a new account, which allows many users to share the phone resource in different times. To use this feature, first you need to configure a Hot Desking key in the advance settings.

This feature is supported on the version 1.0.3.82 or later.

To configure the Hot Desking via Phone interface

1. Press Menu→ Features→ Function Keys→ Line Keys as Function Keys→ Line Key2(for example)
2. Press  and  key to select the Hot Desking in the Type field.
3. Press  or Save soft key to save the configuration.

To configure the Hot Desking via Web interface:

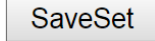
1. Click Function Keys→ Line Key.
2. Select the desired Line Key and select Hot Desking in the Type field.
3. Click the  button to save the configuration.

Line	Type	Mode	Value	Label	Account	Extension
Key1	Line	Default		243	Account 1	
Key2	Hot Desking	Default			Account 1	

To use the Hot Desking feature on the user interface:

1. Press the Hot Desking key when the IP Phone is idle.
 2. "Clear all other account config?" is shown on the screen and press OK.
 2. Enter the Extension number and password
 3. Click Save soft key
- You can see the account information which has changed.



Note:

This feature is not available on all servers. For more information, contact your system administrator.

Automatic Call Distribution (ACD)

ACD feature is often used in offices for customer service, such as call center. The ACD system handles large volumes of incoming calls from callers who have no need to talk to a specific person but who require assistance from any of the different personnel at the earliest point. The ACD feature on the IP Phone allows the ACD system to distribute calls from large volumes of incoming calls to the registered IP phone users. To use this feature, first you should configure an ACD key in the advance settings.

To configure the ACD via Phone interface

1. Press Menu→ Features→ Function Keys→ Line Keys as Function Keys→ Line Key2(for example)
2. Press  and  key to select the ACD in the Type field.

3. Select the desired account in the Account ID field.
4. Press or Save soft key to save the configuration.

To configure the ACD via Web interface:

1. Click Function Keys→ Line Key.
2. Select the desired Line Key and select ACD in the Type field.
3. Select the desired account from the pull-down list of Account field.
4. Click the button to save the configuration.

Line	Type	Mode	Value	Label	Account	Extension
Key1	Line	Default		243	Account 1	
Key2	ACD	Default			Account 1	

Note:

This feature is not available on all servers. For more information, contact your system administrator.

Directory

This section provides the operating instructions for managing contacts. The topics include:

- Local Directory
- Remote Phonebook
- LDAP
- Search Contact

Local Directory

In the directory, you can add or delete your friends, business partner or anyone others' phone No., so you will not forget their number. Or put some anonymous phone No. in the blacklist to prevent from being disturbed. The local Directory can add up to 10000 contacts.

Contact Groups

11. Adding Contact Groups

To organize your contacts and make them easier to find, you can add additional groups in the Local Directory.

To Add Contact Group in the Local Contacts

1. Select Directory or navigate to Menu -> Directory -> Local Contacts.
2. Press the Add softkey.
3. Enter the desired group name.
4. Select the desired Ring Tone.

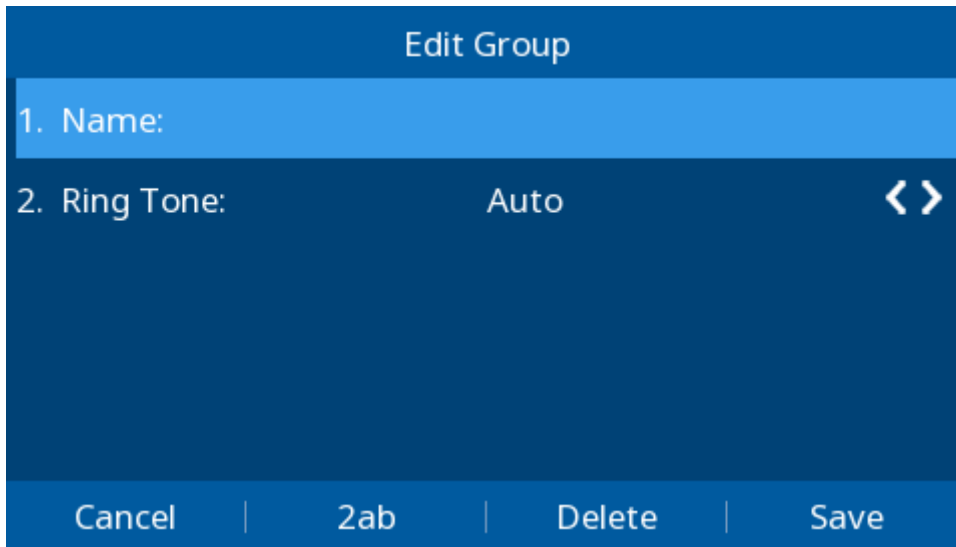

5. Press the Save softkey or press  to save the configuration.

12. Editing Contact Groups

You can change or add the group's information.

To edit Contact Group in the Local directory

1. Select Directory or navigate to Menu -> Directory -> Local Contacts.
2. Select a group (The default Contacts group cannot be edited).
3. Press the Option soft key.

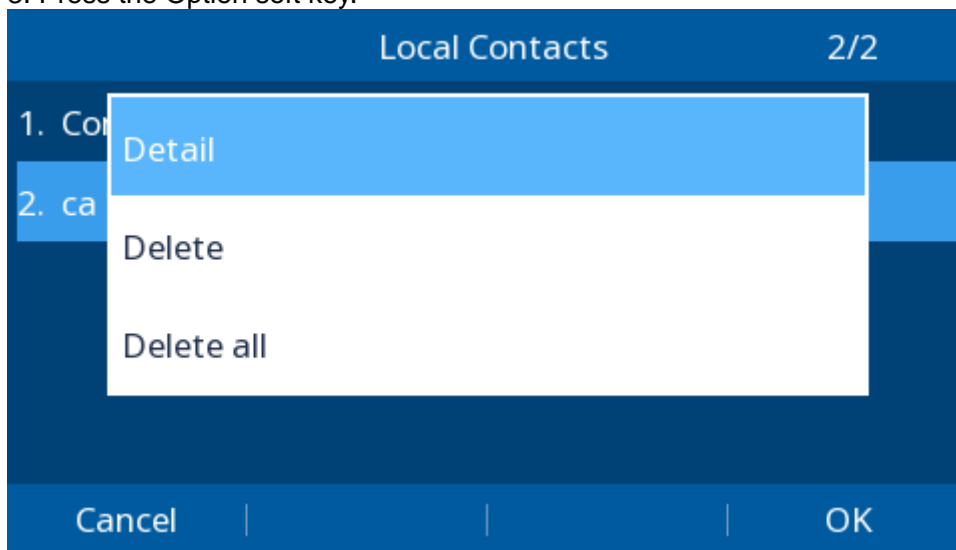

4. Select the Detail and press OK soft key or press .

5. Edit the group information.

6. Press the Save softkey or press  to save the configuration.

13. Deleting Contact Groups

When deleting a contact group, the Contacts group will not be deleted.

To delete Contact Group in the Local directory

1. Select Directory or navigate to Menu -> Directory -> Local Contacts.
2. Select a group (The default Contacts group cannot be edited).
3. Press the Option soft key.

4. Select the Delete and press OK soft key or press .

Managing the Local Directory Contacts

You can manage the Local Directory contacts when the phone is idle.

14. Adding Contacts

After adding a contact to the local directory, you can choose to enter relevant information for the contact. At a minimum, you need to enter the contact's name for each new contact.

To Adding Contacts via Phone interface

1. Select Directory or navigate to Menu -> Directory -> Local Contacts.
2. Select the desired contact group or Contacts.
3. Press Add soft key.
4. Enter your contact's information, name (Name cannot be empty).

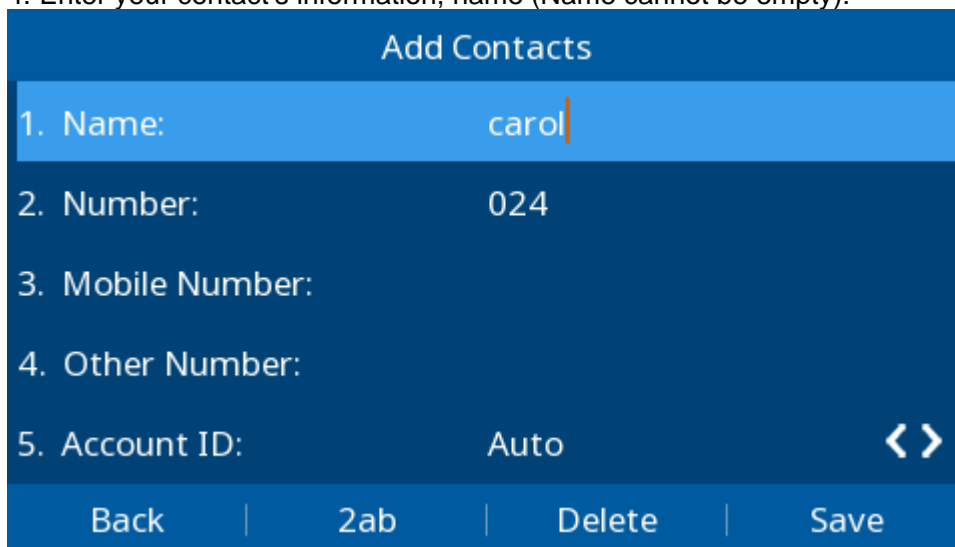

1. Name: carol

2. Number: 024

3. Mobile Number:





4. Other Number:

5. Account ID: Auto < >

Back | 2ab | Delete | Save

5. Press the Save softkey or press  to save the configuration.

To add contacts from history via Phone interface:

1. Press History soft key or press Menu→ History→ All/ Missed/ Received/ Dialed/ Forwarded Calls
2. Press  and  to select the targeted one. (Press  and  switched among the All Calls, Missed Calls, Received Calls, Dialed Calls and Forwarded Calls).
3. Press Option soft key→ Add to Contacts
4. Edit the necessary information as Name, Phone number...
5. Press Save soft key or  to add the contacts successfully.

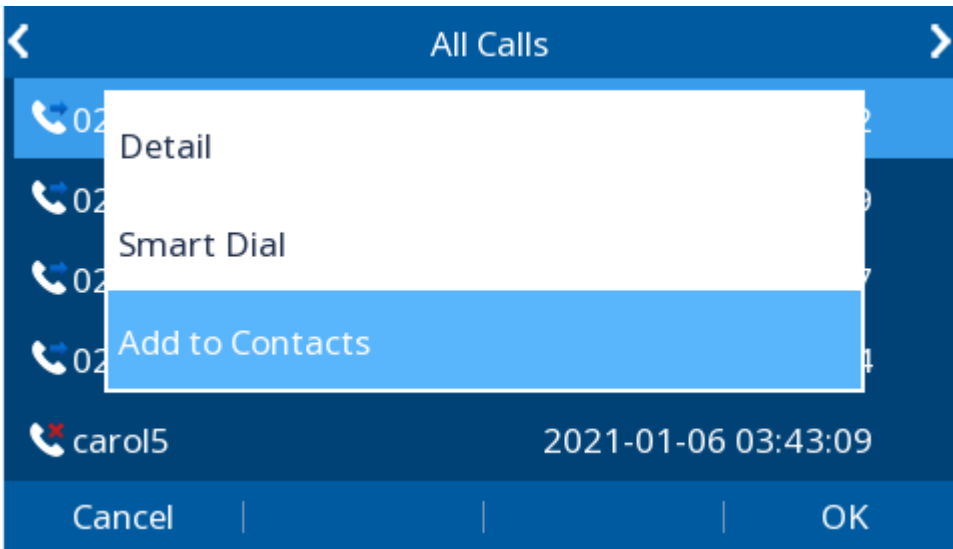

To add contacts via Web interface:

1. Click Directory→ Directory
2. Enter the name, number, and some other information.
3. Press and then press button.



15. Viewing Contacts



To view Contacts in the Local Contacts:

1. Select Directory or navigate to Menu -> Directory -> Local Contacts.
2. Select the desired contact group or Contacts.
3. Press Enter soft key or press .

16. Editing Contacts

You can update your contacts' information.



To edit Contacts in the Local Contacts:

1. Select Directory or navigate to Menu -> Directory -> Local Contacts.
2. Select the desired contact group or Contacts.
3. Press Enter soft key or press .
4. Press the Option soft key.
5. Select the "Detail" option and press the OK or .
6. Edit the contact information (Name, Number).
7. Press the Save softkey or press  to save the configuration.

17. Deleting a Contact

You can delete any contact from the Local Contacts.



To delete Contacts in the Local Contacts:

1. Select Directory or navigate to Menu -> Directory -> Local Contacts.
2. Select the desired contact group or Contacts.
3. Press Enter soft key or press .
4. Press the Option soft key.
5. Select the "Delete" option and press the OK or .
6. And prompt "Are you sure to delete this item?".
7. Press OK soft key or .

18. Deleting All Contacts

You can delete all contacts from the Local Directory.





To delete all Contacts in the Local Contacts:

1. Select Directory or navigate to Menu -> Directory -> Local Contacts.
2. Select the desired contact group or Contacts.
3. Press Enter soft key or press .
4. Press the Option soft key.
5. Select the "Delete" option and press the OK or .
6. And prompt "Are you sure to delete this item?".
7. Press OK soft key or .

Moving a Local Directory Contact to Blacklist

You can move a contact in the Local Directory to blacklist. Incoming calls from this contact will be rejected automatically.

To move a local Contacts to Blacklist:

1. Select Directory or navigate to Menu -> Directory -> Local Contacts.
2. Select the desired contact group or Contacts.
3. Press Enter soft key or press .
4. Press the Option soft key.
5. Press  and  and select the "Add to Blacklist" option and press the OK or .
6. And prompt "Move item to Blacklist, Are you sure?".
7. Press OK soft key or .

Searching for Contacts

In the Local Directory, you can enter search criteria to find your desired contact quickly.

To search contacts in the local contacts:

1. Select Directory or navigate to Menu -> Directory -> Local Contacts.
2. Press Search soft key, Enter your search criteria in the search field.

Upload Contacts photo

Upload Contacts photo via Web interface:

1. Click Directory→ Directory and select the desired contact.

2. Click  to select the photo for the contact.

3. Click  to upload the photo.

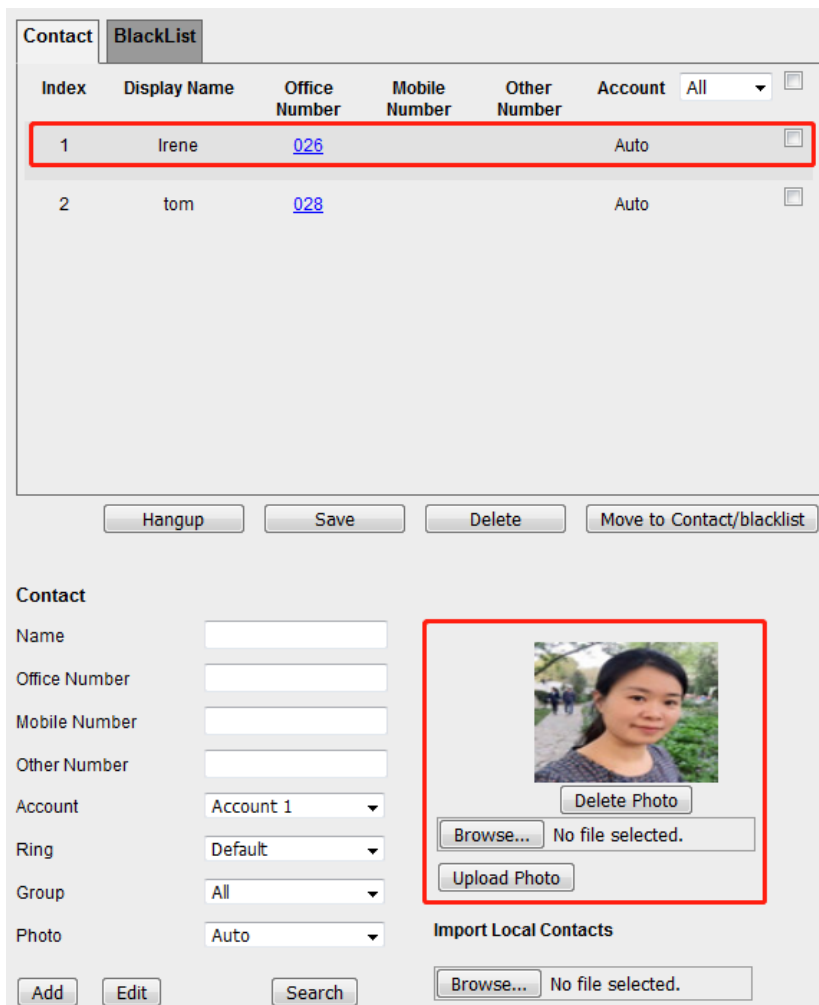

Index	Display Name	Office Number	Mobile Number	Other Number	Account
1	Irene	026			Auto
2	tom	028			Auto

Buttons: Hangup, Save, Delete, Move to Contact/blacklist

Contact Form Fields:

- Name:
- Office Number:
- Mobile Number:
- Other Number:
- Account: Account 1 (dropdown)
- Ring: Default (dropdown)
- Group: All (dropdown)
- Photo: Auto (dropdown)

Photo Upload Section:

- Photo: 
- Delete Photo
- Browse... No file selected.
- Upload Photo

Import Local Contacts:

- Browse... No file selected.

When you place a call from the contact, the phone idle screen will show the contact photo.

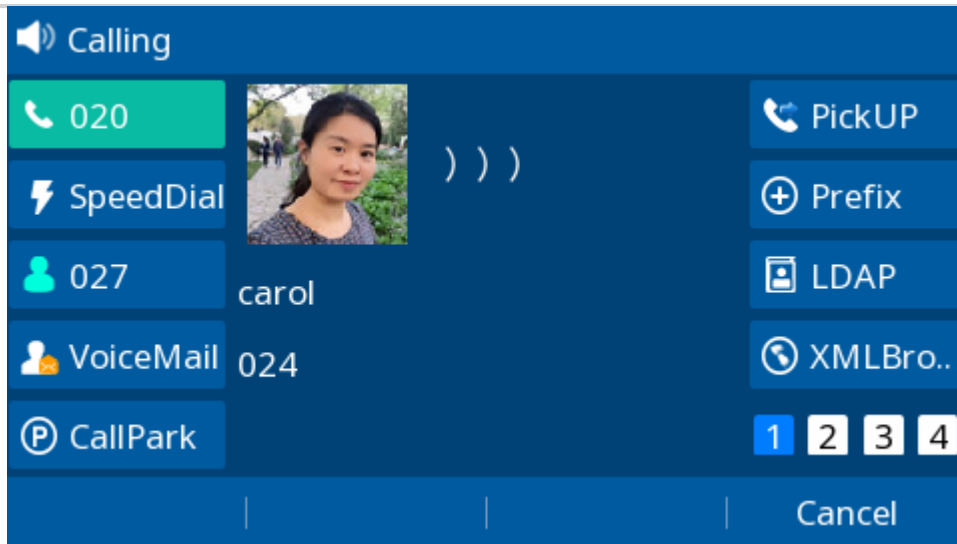

Note:

The size of each photo file cannot exceed 10KB, and the size does not exceed 100x100 pixels.

Contacts photo server

The user can obtain the latest photo of the corresponding account contact through the server. First, click Setting→ Preference, and fill in the Contacts Photo Server path (e.g. <http://192.168.1.18/photo/>). Maximum length of contact photo server parameter 255.

Contacts Photo Server

<http://192.168.1.18/photo/>

Then, place the photo files in the server folder, the file name format is "XXX.jpg", "XXX" is the extension number of the corresponding contact.

When the phone is on a call, the corresponding photos will be obtained from the server for display.

```
<?xml version="1.0" encoding="UTF-8"?>
<contactData>
  <group>
    <contact sDisplayName="075" sOfficeNumber="075" sMobilNumber="" sOtherNumber="" sAccountIndex="255" sRing="Auto" group="" photoDefault="Config:gee.jpg" photoSelect="0" />
    <contact sDisplayName="076" sOfficeNumber="076" sMobilNumber="" sOtherNumber="" sAccountIndex="255" sRing="Auto" group="" photoDefault="Config:gtek.jpg" photoSelect="0" />
  </group>
  <blacklist>
  </blacklist>
  <groupinfo>
  </groupinfo>
</contactData>
```

Note:

- 1.If the photo of the corresponding contact in the phone book has been configured through the web page, it will be used first instead of the photo on the server.
- 2.The size of each photo file on the server cannot exceed 10KB.

To import or export the contact list

You can manage your phone's local directory via phone or web user interface. But you can only import or export the contact list via Web interface.

To import an XML file of contact list via Web interface:

1. Click on Directory→ Directory
2. Click to select a contact list file (file format must be .xml) from your local system.
3. Click to import the contact list.

To export an XML file of contact list via Web interface:

1. Click on Directory→ Directory
2. Click to export the contact list.

To import a CSV file of contact list via Web interface:

1. Click on Directory→ Directory
2. Click to select a contact list file (file format must be .csv) from your local system.
3. Click to import the contact list.

To export a CSV file of contact list via Web interface:

1. Click on Directory→ Directory
2. Click to export the contact list.

Contact

Name

Office Number

Mobile Number

Other Number

Account

Ring

Group

Photo

GroupInfo

Group

Ring

Import Local Contacts

No file selected.

No file selected.

Show Title

Note:

If the XML file or CSV file has more than 10000 contacts, the phone will only upload 10000 contacts.

Blacklist

Incoming calls from the Blacklist are rejected automatically.

Adding a Blacklist Contact

You can add a blacklist contact on the phone to prevent someone from calling you.

To add a blacklist contact via phone interface:

1. Select Directory or navigate to Menu -> Directory -> Blacklist.
2. Select Add soft key.
3. Enter the desired value (Name, Number...)
4. Press the Save button to save the configuration.

To add a blacklist contact via web interface:

1. Click the webpage->Directory->Directory -> BlackList
2. Fill in the desired value in the contact (Name, Number).
3. Click the Add button and save the configuration.

Index	Display Name	Office Number	Mobile Number	Other Number	Account
1	Lucy	027			Auto

Buttons: Hangup, Save, Delete, Move to Contact/blacklist

Contact details form:
Name: Lily
Office Number: 030
Mobile Number:
Other Number:
Account: Auto
Buttons: Add, Edit, Search, Delete Photo, Browse..., Upload Photo

Viewing Blacklist Contacts

You can view the blacklist contacts from the Blacklist on your phone.

To view blacklist contact via phone interface:

1. Select Directory or navigate to Menu -> Directory -> Blacklist.

Editing a Blacklist Contact

You can update your blacklist contacts' information.

To edit a blacklist contact via phone interface:

1. Select Directory or navigate to Menu -> Directory -> Blacklist.
2. Press the Option soft key and select the Detail.
3. Modify the desired value (Name, Number...)
4. Press the Save button to save the configuration.

Deleting Blacklist Contacts

You can delete one or all blacklist contacts. If a contact is removed from the blacklist, you can answer the call from the contact normally.

19. Deleting a Blacklist Contact

If you want to answer a call from a specific contact, you need to remove it from the Blacklist.

To delete blacklist contact via phone interface:

1. Select Directory or navigate to Menu -> Directory -> Blacklist.
2. Press the Option soft key and select the Delete.
3. Press the OK soft key and a pop-up box "Are you sure to delete this item?".
4. Press OK soft key to confirm deletion.

20. Deleting All Blacklist Contacts

You can delete all contacts from the Blacklist when you are ready to answer calls from them again.

To delete all blacklist contact via phone interface:

1. Select Directory or navigate to Menu -> Directory -> Blacklist.
2. Press the Option soft key and select the Delete All.
3. Press the OK soft key and a pop-up box "Are you sure to delete all items?".
4. Press OK soft key to confirm deletion.

Moving a Blacklist Contact to the Local Directory

You can move a blacklist contact to a Local Directory. Incoming calls from this contact will not be rejected automatically.

To move a blacklist contact to the Local Directory via phone interface:

1. Select Directory or navigate to Menu -> Directory -> Blacklist.
2. Press the Option soft key and select the Add to Contacts.
3. Press the OK soft key and a pop-up box "Move item to contacts, Are you sure?".
4. Press OK soft key.

To move a blacklist contact to the Local Directory via web interface:

1. Click the webpage->Directory->Directory -> BlackList
2. Select the contact you want to remove.
3. Click the Move to Contact/blacklist.

Contact BlackList

Index	Display Name	Office Number	Mobile Number	Other Number	Account	All
1	Lily	030			Auto	<input type="checkbox"/>
2	Lucy	027			Auto	<input checked="" type="checkbox"/>

Hangup Save Delete Move to Contact/blacklist

Remote Phonebook

To set Remote Phonebook via Web interface:

1. Login the webpage and click Directory→ Remote Phone Book
2. Fill in the URL of the remote file in the Phone Book URL field. For example, `http://10.2.0.140/Phonebook/remotephonebook.xml`
3. Fill in the Name and then click SaveSet to save the configuration.

Index	PhoneBook URL	Name
1	<input type="text" value="http://10.2.0.140/Phonebook/remotephoneboc"/>	<input type="text" value="test1"/>
2	<input type="text"/>	<input type="text"/>
3	<input type="text"/>	<input type="text"/>
4	<input type="text"/>	<input type="text"/>
5	<input type="text"/>	<input type="text"/>

Update Time Interval(minutes) ?

SaveSet Cancel

To check the contacts via Phone interface:

1. Press Directory→ Remote Contacts or Menu→ Directory→ Remote Contacts, and then you can see the item you set.
2. Select the item and press Update.
3. After updating completely, press Enter and you will find the detail.

Note:

Every remote phonebook, only supports 10000 contacts.

To search contact in Remote Contacts:

1. Click the Directory soft key on Idle interface.
2. Select the Remote Contacts and click Enter.
3. Select the desired remote phonebook and click Enter soft key.
4. Click the Search soft key, you can enter the desired part of name or part of number.
5. With the search content to match the contact will be automatically displayed on the LCD within 5 seconds.

LDAP Phonebook

When use the LDAP feature, you can get the LDAP Phonebook directly.

To configure LDAP via Web interface:

1. Login webpage and click Directory→ LDAP
 2. Fill in the LDAP Name Filter:
 - a) This parameter specifies the name attributes for LDAP searching. The “%” symbol in the filter stands for the entering string used as the prefix of the filter condition.
 - b) For example, (cn=%), when the name prefix of the cn of the contact record matches the search criteria, the record will be displayed on the IP PHONE LCD.
 3. Fill in the LDAP Number Filter: This parameter specifies the number attributes for LDAP searching.
 4. Fill in Server Address: Fill in the domain name or IP address of the LDAP Server. For example: 192.168.0.253
 5. Port (the port of the LDAP Server), Base, User Name, Password
 6. Max.Hits(1-32000): the maximum number of the search results to be returned by the LDAP server.
 7. LDAP Display Name: the display name of the contact record displayed on the LCD screen.
 8. Filled in the relative value and then click to save the settings.
- Following is the example screenshot for the configuration.

LDAP Name Filter	<input type="text" value="(cn=%)"/>	?
LDAP Number Filter	<input type="text" value="((telephoneNumber=%)"/>	?
Server Address	<input type="text" value="192.168.0.107"/>	?
Port	<input type="text" value="389"/>	?
Base	<input type="text" value="dc=pbx,dc=com"/>	?
User Name	<input type="text" value="cn=admin,dc=pbx,dc=cc"/>	?
Password	<input type="password" value="●●●●●●●●"/>	?
Max.Hits(1~32000)	<input type="text" value="32000"/>	?
LDAP Name Attributes	<input type="text"/>	?
LDAP Number Attributes	<input type="text"/>	?
LDAP Display Name	<input type="text" value="cn"/>	?
Protocol	<input checked="" type="radio"/> Version2 <input type="radio"/> Version3	?
LDAP Lookup For Call	<input type="radio"/> On <input checked="" type="radio"/> Off	?
LDAP Sorting Results	<input type="radio"/> On <input checked="" type="radio"/> Off	?
LDAP Synchronize Time(0~9999mins)	<input type="text"/>	?

To configure LDAP Key via Web interface:

1. Click Function Keys→ Line Key→ choose Line Key2(for example)
2. Select LDAP in the Type field.
3. Click to save the configuration.

Line	Type	Mode	Value	Label	Account	Extension
Key1	Line	Default		243	Account 1	
Key2	LDAP	Default			Account 1	

To Configure LDAP Key via Phone interface:

1. Press Menu→ Features→ Function Keys→ Line Keys as Function Keys→ Line Key2
2. Select LDAP in the Type field
3. Press Save or key to save the configuration.

When press the LDAP Key the LCD will display as following:

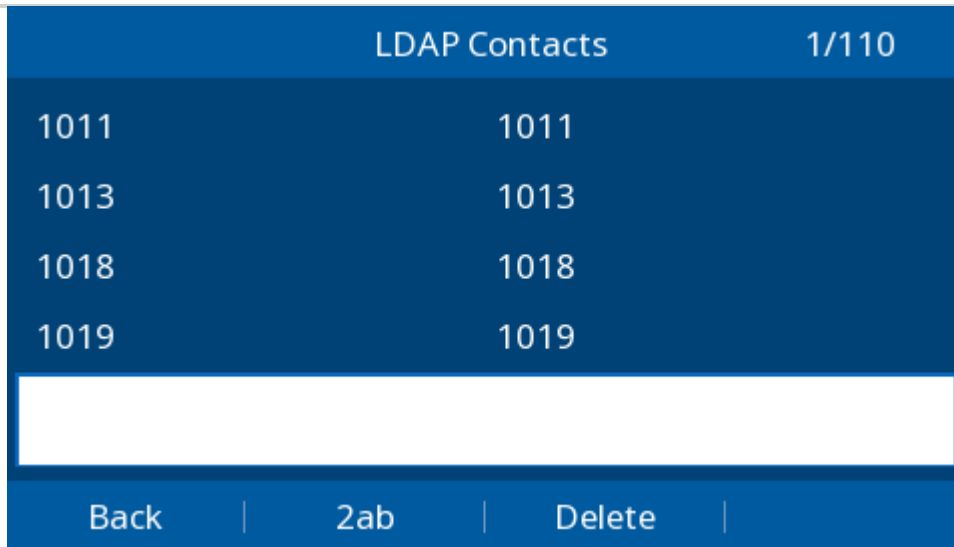

To search contact in LDAP contacts:

1. Click the Directory soft key on Idle interface.
2. Select the LDAP Contacts and click Enter.
3. Enter the first character or more of contact's name or number.
4. With the search content to match the contact will be automatically displayed on the LCD within 5 seconds.

Call History Setting

Call History

This phone maintains call history lists of All Calls, Dialed Calls, Received Calls, Missed Calls and Forwarded Calls. The call history list supports up to 100 entries in all on phone interface and more than 1500 items. You can check the call history, dial a call, add a contact, or delete an entry from the call history list. You should enable the history record feature in advance.



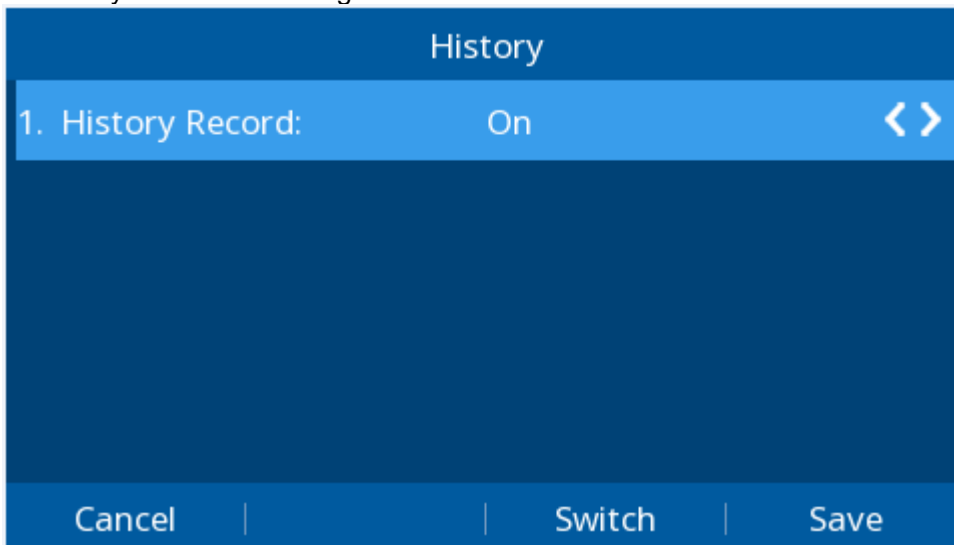

To enable the history record feature via Phone interface:

1. Press Menu→ Features→ History
2. Press and or Switch soft key set History record: On.
3. Press Save soft key to save the configuration.





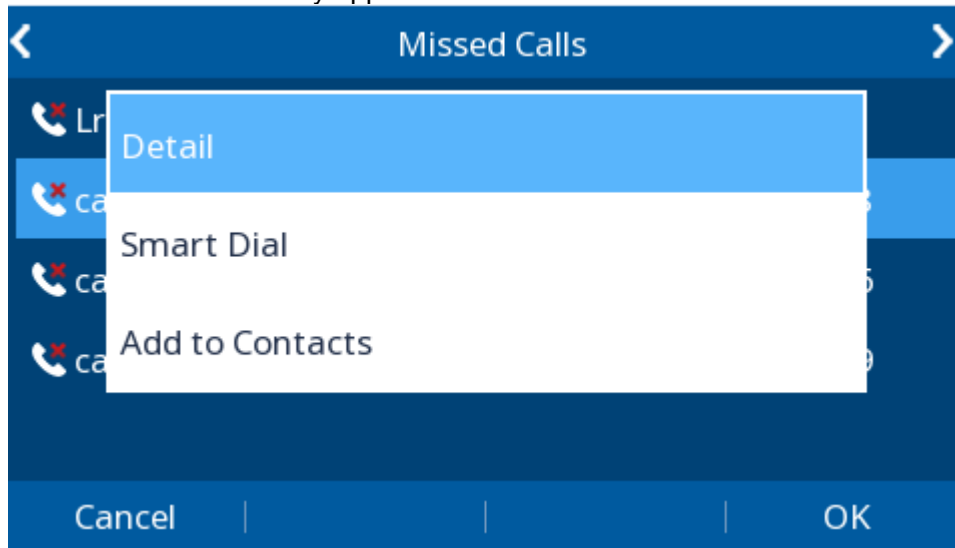

To view the call history via Phone interface:

1. Press the History soft key or press Menu→ History→ All/ Missed/ Received/ Dialed/ Forwarded Calls. The LCD screen displays All Calls list.





2. Press  and  to switch among All Calls, Missed Calls, Received Calls, Dialed Calls and Forwarded Calls.
3. Press  or  to select the desired entry.
4. Press the Option soft key, then select Detail from the prompt list and press the OK soft key.
5. The detailed information of the entry appears on the LCD screen.





To Dial a call from Call History via Phone interface:

1. Press the History soft key or press Menu→ History→ All/ Missed/ Received/ Dialed/ Forwarded Calls.
2. Press  and  to switch among All Calls, Missed Calls, Received Calls, Dialed Calls and Forwarded Calls.
3. Press  or  to select the desired entry.
4. Press the send soft key or .





To delete an entry from the call history list via Phone interface:

1. Press the History soft key or press Menu→ History→ All/ Missed/ Received/ Dialed/ Forwarded Calls.
2. Press  and  to switch among All Calls, Missed Calls, Received Calls, Dialed Calls and Forwarded Calls.
3. Press  or  to select the desired entry.
4. Press the Delete soft key.

To delete all entries from the call history list via Phone interface:





1. Press the History soft key or press Menu→ History→ All/ Missed/ Received/ Dialed/ Forwarded Calls.
2. Press  and  to switch among All Calls, Missed Calls, Received Calls, Dialed Calls and Forwarded Calls.
3. Press the Option soft key, and then select Delete All from the prompt list.
4. Press the OK soft key to confirm the deleting or the Cancel soft key to cancel.

To add to Local Contacts from history via Phone interface:

1. Press History soft key or press Menu→ History→ All/ Missed/ Received/ Dialed/ Forwarded Calls
2. Press  or  to select the targeted one. (Press  and  switched among the All Calls, Missed Calls, Received Calls, Dialed Calls and Forwarded Calls).
3. Press Option soft key→ Add to Contacts.
4. Edit the necessary information as Name, Phone number...
5. Press Save soft key or  to add successfully.

To add to blacklist from history via Phone interface:

1. Press History soft key or press Menu→ History→ All/ Missed/ Received/ Dialed/ Forwarded Calls

2. Press  or  to select the targeted one. (Press  and  switched among the All Calls, Missed Calls, Received Calls, Dialed Calls and Forwarded Calls).
3. Press Option soft key→ Add to Blacklist
4. Edit the necessary information as Name, Phone number...
5. Press Save soft key or  to add successfully.

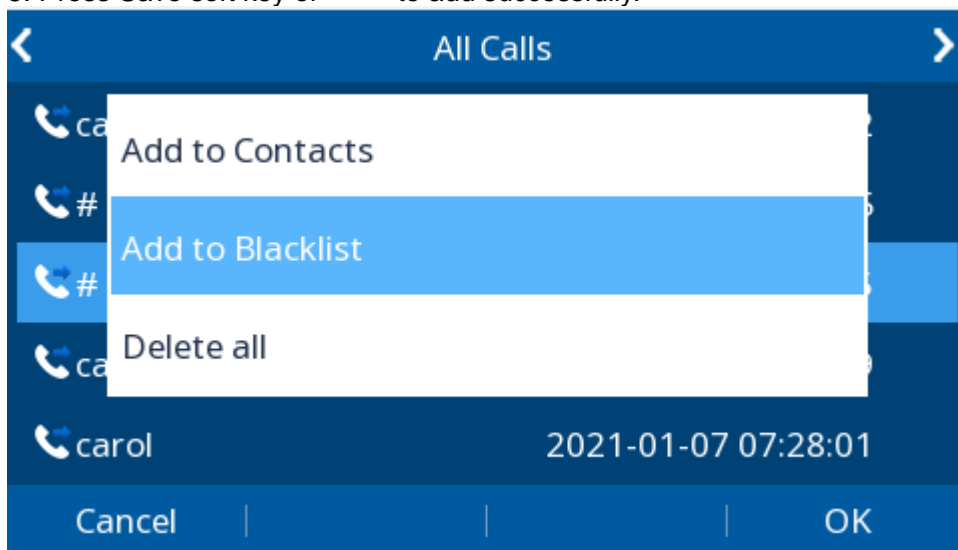

To check the call history via Web interface:

1. Click Directory→ Call History
2. Click Dialed List, Missed List, Received List, or Forwarded List, then you can see the history list.

Dial List						Missed List						Received List						Forwarded List					
Index	Date	Time	Local Identity	Name	Tel Number																		
1	05-07-2019	05:26:21		amy	013																		
2	05-07-2019	04:39:40		004	004																		
3	03-04-2019	07:34:57		1105	1105																		
4	03-04-2019	07:33:43		1105	1105																		
5	03-04-2019	07:32:23		1105	1105																		
6	03-04-2019	07:31:09		1105	1105																		
7	03-04-2019	07:29:55		1105	1105																		
8	03-04-2019	07:28:41		1105	1105																		
9	03-04-2019	07:27:27		1105	1105																		
10	03-04-2019	07:26:13		1105	1105																		
11	03-04-2019	07:24:59		1105	1105																		
12	03-04-2019	07:23:45		1105	1105																		
13	03-04-2019	07:22:31		1105	1105																		
14	03-04-2019	07:21:17		1105	1105																		
15	03-04-2019	07:20:02		1105	1105																		
16	03-04-2019	07:18:48		1105	1105																		
17	03-04-2019	07:17:34		1105	1105																		
18	03-04-2019	07:16:09		1105	1105																		

Export XML Export Csv

To Dial a call from Call History via Web interface:

1. Click Directory→ Call History
2. Select the desired history item and click Tel Number.
3. Then the call is dialed on phone.

Dialed List				Missed List		Received List		Forwarded List	
Index	Date	Time	Local Identity	Name	Tel Number				
1	05-07-2019	05:26:21		amy	013				
2	05-07-2019	04:39:40		004	004				
3	03-04-2019	07:34:57		1105	1105				
4	03-04-2019	07:33:43		1105	1105				
5	03-04-2019	07:32:23		1105	1105				
6	03-04-2019	07:31:09		1105	1105				
7	03-04-2019	07:29:55		1105	1105				
8	03-04-2019	07:28:41		1105	1105				
9	03-04-2019	07:27:27		1105	1105				
10	03-04-2019	07:26:13		1105	1105				
11	03-04-2019	07:24:59		1105	1105				
12	03-04-2019	07:23:45		1105	1105				
13	03-04-2019	07:22:31		1105	1105				
14	03-04-2019	07:21:17		1105	1105				
15	03-04-2019	07:20:02		1105	1105				
16	03-04-2019	07:18:48		1105	1105				
17	03-04-2019	07:17:34		1105	1105				
18	03-04-2019	07:16:09		1105	1105				



Export XML Export Csv

Audio Settings

Ring Tone

You can adjust the type and volume of the ring tone.

To adjust the Ring Tone Type via Phone interface:

1. Press Menu → Settings → Basic Setting → Ring Tone.
2. Press  or  to select the aimed one.
3. Press  or Save soft key to save the configuration.



To adjust the Ring Tone Type via Web interface

1. Setting→ Preference→ Ring Tones
2. Select the wanted one and enter the Ring Volume
3. Click to save the configuration.

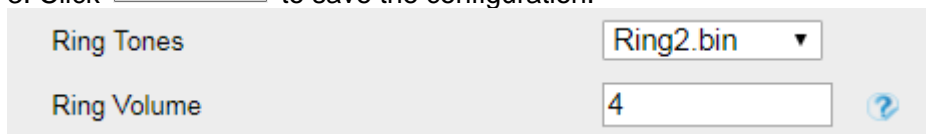

To configure Distinctive Ring Tone via Phone interface

1. Press Directory→ Local Contacts/ LDAP
2. Select the target contact.
3. Press Option soft key and select detail to edit the contact.
4. Press and to select the wanted Ring Tone for the contact
5. Press Save soft key to save the contact.

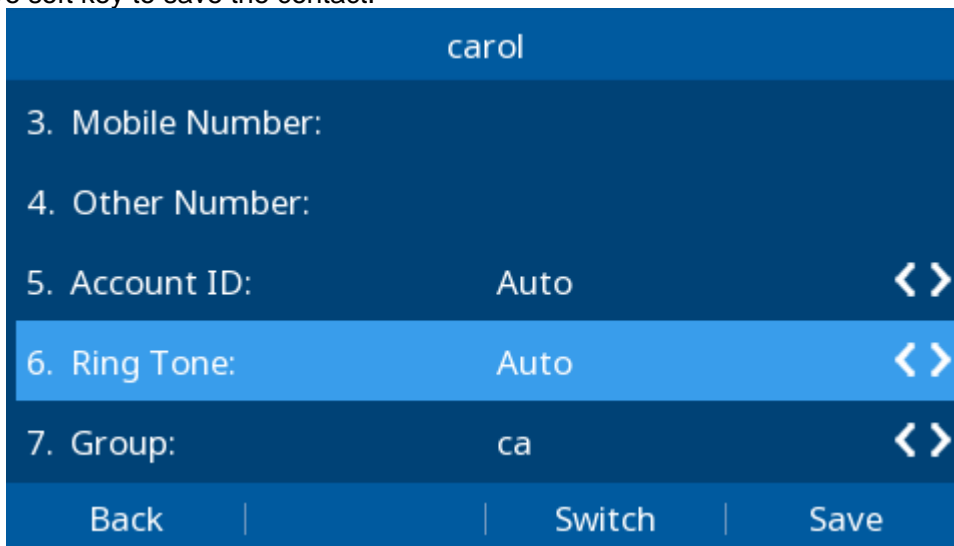



To configure Distinctive Ring Tone via Web interface

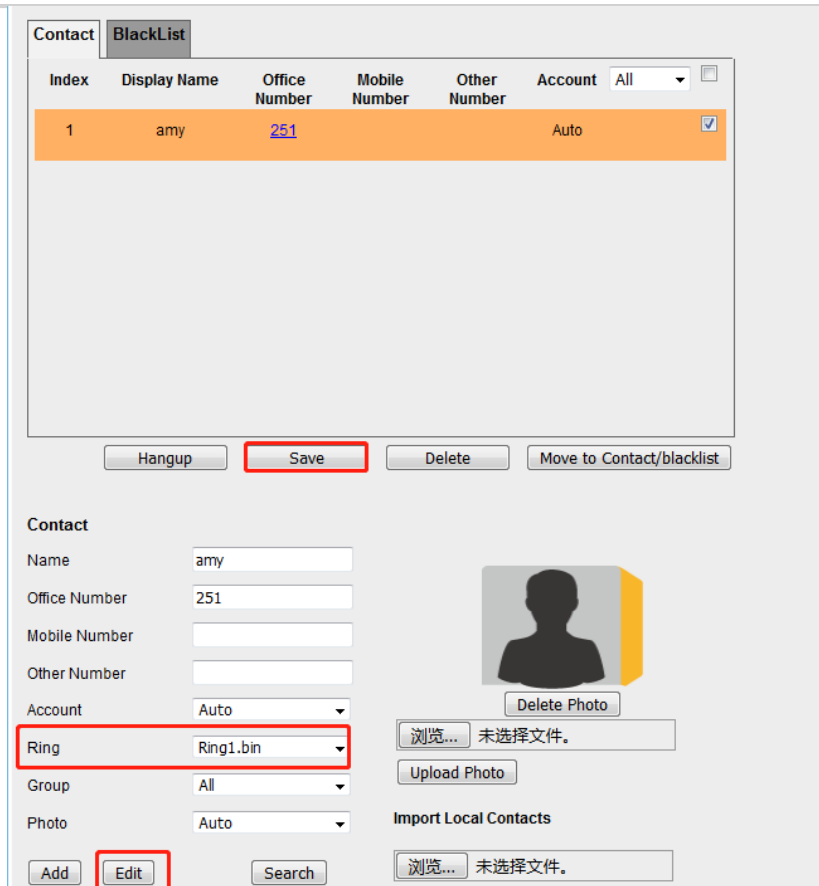

1. Directory→ Directory→ Contact
2. Select the target contact.
3. Choose the Ring Tone you want to use.
4. Click → to save the configuration.



Volume



You can adjust the volume for the phone by the volume keys:  and .

To adjust the Ring tone volume via Phone interface:

1. Option 1: To press  and  on the idle page



2. Option 2: To press  and  during the call is ringing.

To adjust the handset volume via Phone interface:

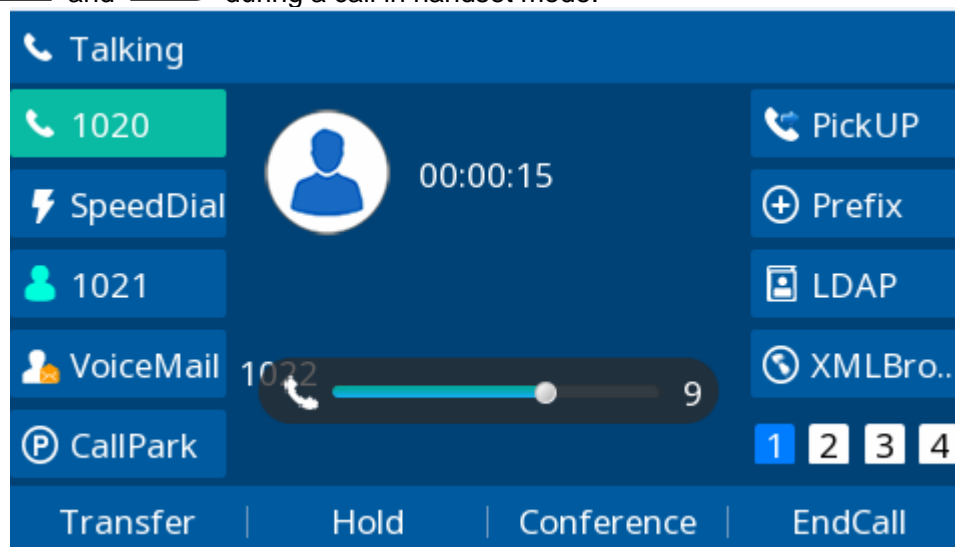
To press  and  during a call in handset mode.



To adjust the headset volume via Phone interface:

To press  and  during a call in headset mode.

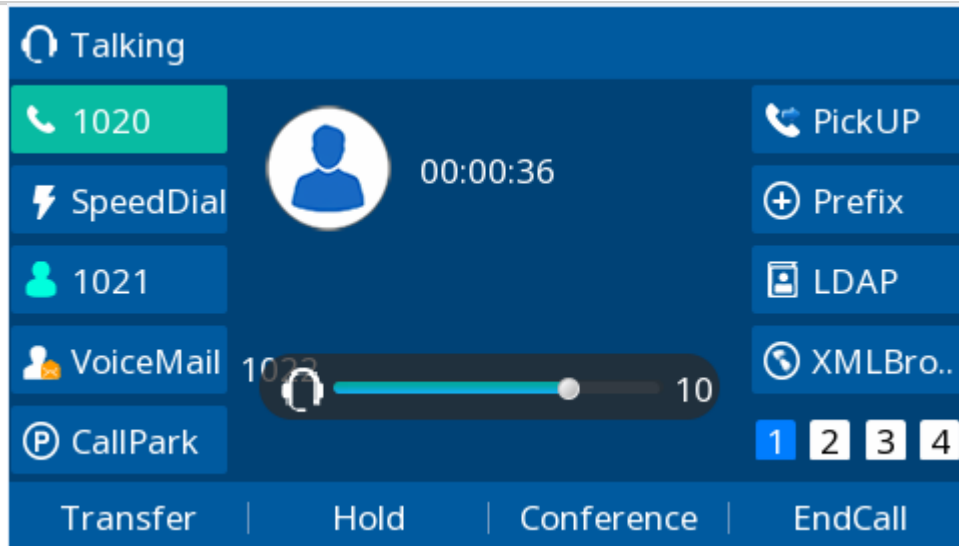

To adjust the speaker Volume via Phone interface:

To press and during a call in speaker mode.

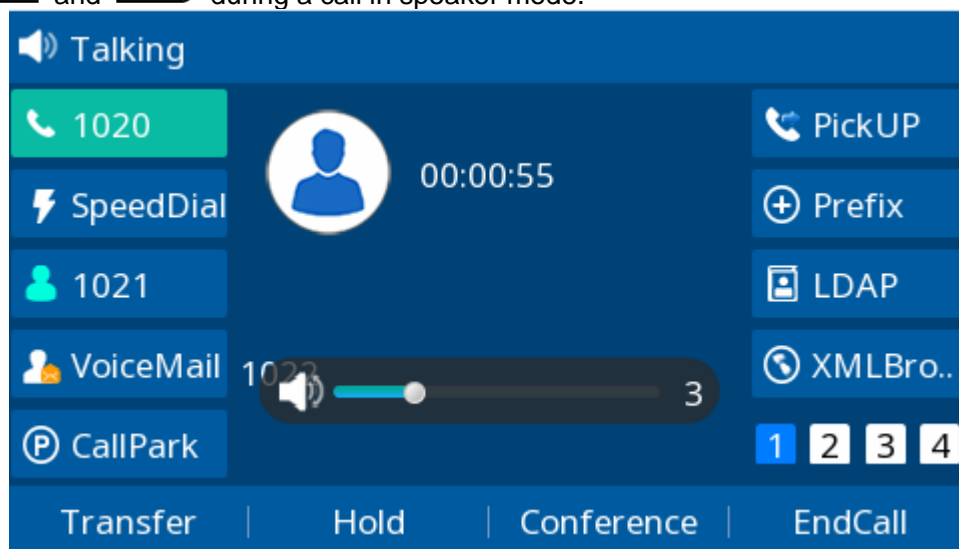

Voice Mail Tone

This option can set whether to play the beep for phone's voice mail.

1. Login webpage, and click the Setting→ Preference
2. Select On or Off for Voice Mail Tone.
3. Click for the setting.

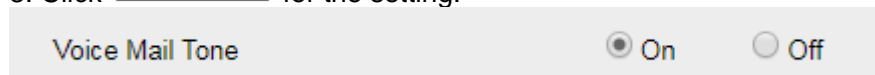

Play Hold Tone

When you hold the phone, whether to play hold tone.

1. Login webpage, and click the Setting→ Preference
2. Set On or Off for Play Hold Tone.
3. Click for the setting.

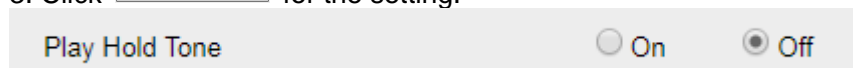

Play Hold Tone Delay

When you hold the phone. How many seconds to play beep?

1. Login webpage, and click the Setting→ Preference
2. Set the value for Play Hold Tone Delay.

3. Click for the setting.

Play Hold Tone Delay	<input type="text" value="3"/>
----------------------	--------------------------------

Voice

Handfree AGC

AGC is the automatic gain control, which amplifies the sound according to the loudness of the speech during use. The most ideal effect when using AGC is that when the sound source is off, when the mic is closer or farther, the sound level on the opposite end is the same.

To configure Handfree AGC via Web interface:

1. Click Setting → Voice.
2. Enable the Handfree AGC field (Default).
3. Click to save the configuration.

[logout](#)

The screenshot shows the IP PHONE web interface. The top navigation bar includes Home, Profile, Account, Network, Function Keys, Setting, Directory, and Management. The left sidebar lists various settings categories: Preference, Features, BLF Settings, Line Settings, Date&Time, Tones, Voice, SMS, Action URL, Softkey Layout, TR069, and SIP. The main content area is titled 'Handfree AGC' and is highlighted with a red box. It contains several configuration options under the 'Volume Amplification' section, including HandSet Send Volume, HeadSet Send Volume, HandFree Send Volume, Handset extra loud, Headset extra loud, Handfree extra loud, Mute Type, VAD Eanble, Jitter Buffer Type, and Jitter Buffer Length. The 'Handfree AGC' field is set to 'Enable'. The 'VAD Eanble' field is set to 'Disable'. The 'Jitter Buffer Type' field is set to 'Adaptive'. The 'Jitter Buffer Length' field is set to 'Medium'. There are 'SaveSet' and 'Cancel' buttons at the bottom of the configuration area. A 'NOTE' section on the right side of the page contains the text 'TR069: Set the TR069.'

Volume Amplification

Handset Send Volume

A fixed gain that controls the volume sent by the Handset.

The AGC feature for handset is enabled by default. If you set this option, the AGC feature for handset will be closed.

To configure Handset Send Volume via Web interface

1. Click Setting → Voice.
2. Select the desired value in the Handset Send Volume field.
3. Click to save the configuration.

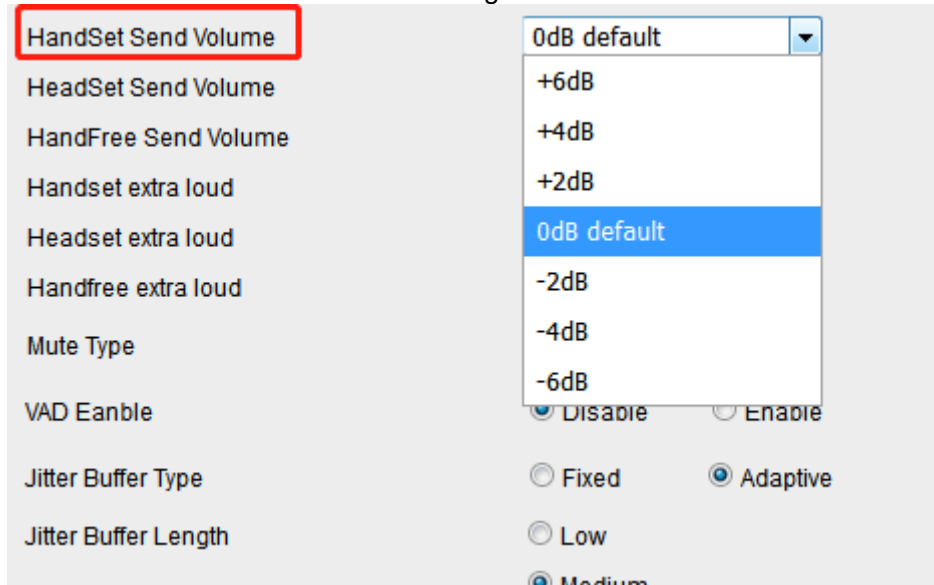

Headset Send Volume

A fixed gain that controls the volume sent by the Headset.

To configure Headset Send Volume via Web interface

1. Click Setting → Voice.
2. Select the desired value in the Headset Send Volume field.
3. Click to save the configuration.

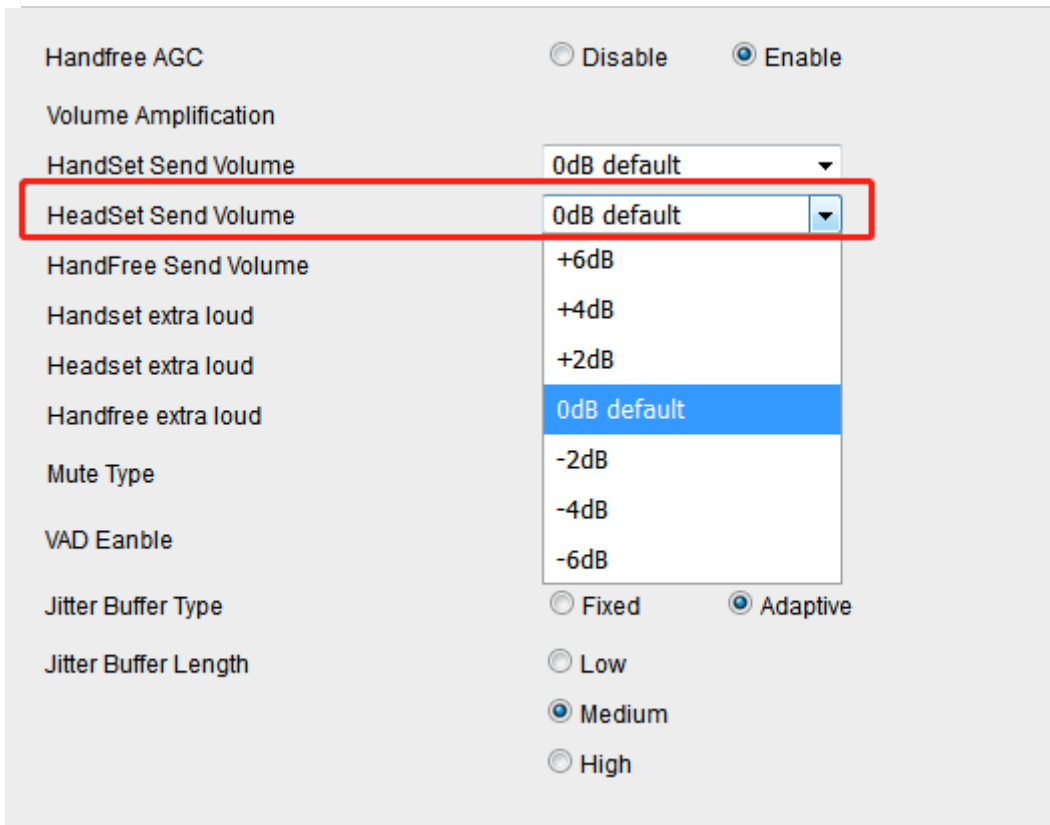

Handfree Send Volume

A fixed gain that controls the volume sent by the Handfree (speakerphone). If Handfree AGC is enable, Handfree Send Volume option will not work.

To configure Handfree Send Volume via Web interface

1. Click Setting → Voice.
2. Select the desired value in the Handfree Send Volume field.
3. Click to save the configuration.

Extra Loud

To configure Handset /Headset/Handfree extra loud via Web interface:

Handset /Headset/Handfree extra loud can control the size of the sound emitted from the speaker, and you can control an additional +2~+12 dB.

1. Click Setting → Voice.
2. Select the desired value in the Handset /Headset/Handfree extra loud field.
3. Click to save the configuration.

Handfree AGC	<input type="radio"/> Disable <input checked="" type="radio"/> Enable
Volume Amplification	
HandSet Send Volume	0dB default ▾
HeadSet Send Volume	0dB default ▾
HandFree Send Volume	0dB default ▾
Handset extra loud	0dB default ▾
Headset extra loud	0dB default
Handfree extra loud	+2dB
Mute Type	+4dB
VAD Eanble	+6dB
Jitter Buffer Type	+8dB
Jitter Buffer Length	+10dB
	+12dB
	<input checked="" type="radio"/> Medium
	<input type="radio"/> High

Note:
Only when the volume adjustment on the LCD is greater than +7, the extra loud will take effect.

USB

USB Recording

You can record active calls onto a USB flash drive connected to your phones, and the recordings are saved as *.wav files.

Recording using a USB flash drive is not available by default. Contact your system administrator for enabling this feature for you.

Supported model: UC507U UC505U UC503U

Note:

The size of a single recording file should be less than 2G.

Before you use USB Recording:

Connect your USB flash driver to your phone, and the phone will show that U Disk Connected.

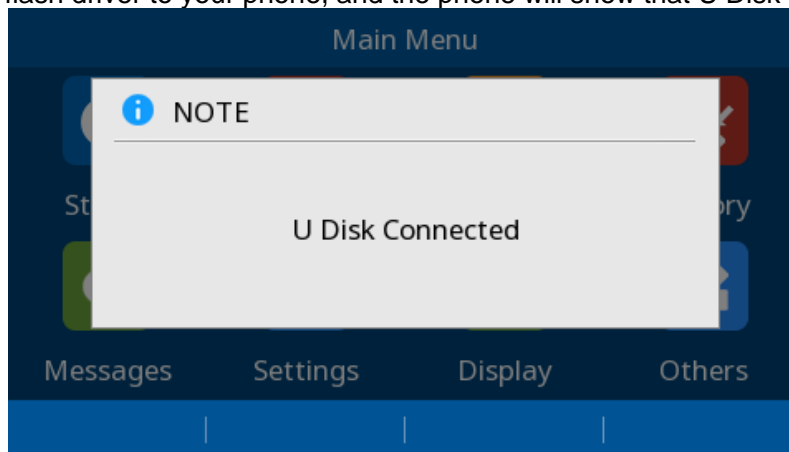

To record a call:

- During a call, press More soft key → Start Rec soft key

When recording starts, the recording icon and recording duration are displayed in the notification bar, and the recording start and available rec time are displayed in a note:

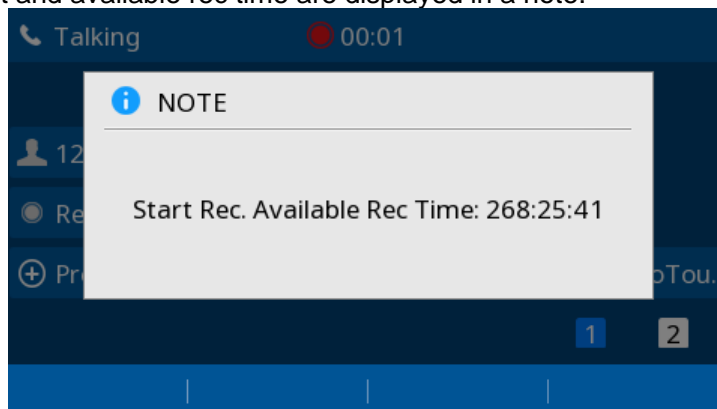

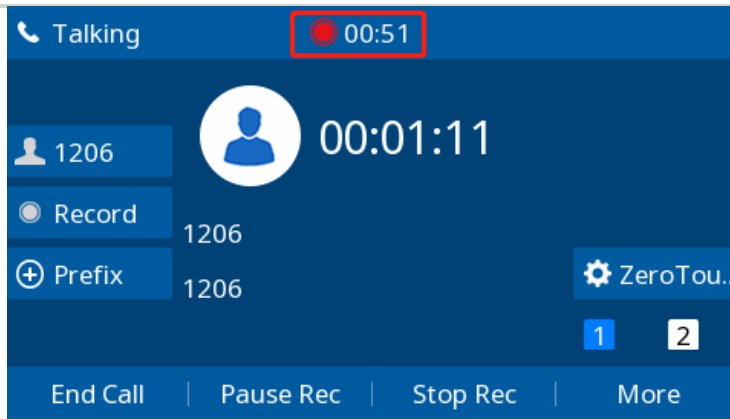

To pause/resume a recording:

- Press Pause Rec soft key to pause the current recording. When a recording is paused, the recording pause icon are displayed in the notification bar.

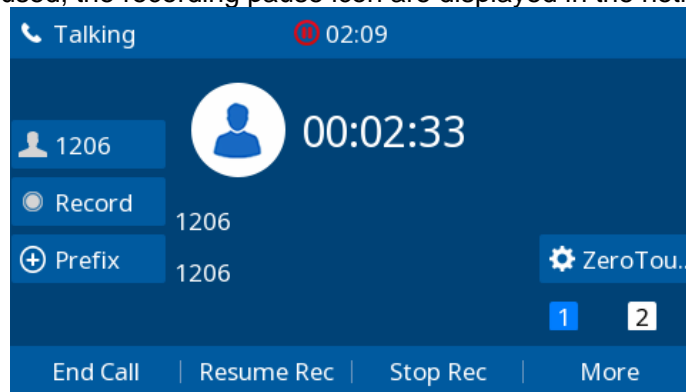

- Press Resume Rec soft key to resume the paused recording.

To stop a recording:

There are two ways to stop recording:

1. End the call directly
2. Press Stop Rec soft key

The call recording will be automatically saved in. Wav format in the corresponding folder of USB drive

Manage your recordings



After stopping recording, you can manage the recordings on your phone. Make sure the USB flash drive is still inserted in the phone.

To listen a recording:

You can view all recorded files in the Browse recordings.

1. Press soft key Menu→ USB→Browse recordings





- press  and  to choose the recording you want to play
- Press  or play soft key to listen the recording

To control playback Progress:

When playing a recording, you can pause, fast forward and rewind.







Pause: Press  to pause or resume the recording.

Fast forward and rewind: Press  and  soft key to fast forward or rewind the recording



To toggle list loop mode:

- Press  to adjust the list loop mode.

There are four loop modes to choose from:

-  mode will loop through all the music in the list.
-  mode will loop single current recording.
-  mode will play the recording until the end of the list.
-  mode will only play to end the current recording.

To delete recordings:

- Press soft key Menu→ USB→Browse recordings
- Press  and  to choose the recording you want to delete
- Press Delete soft key

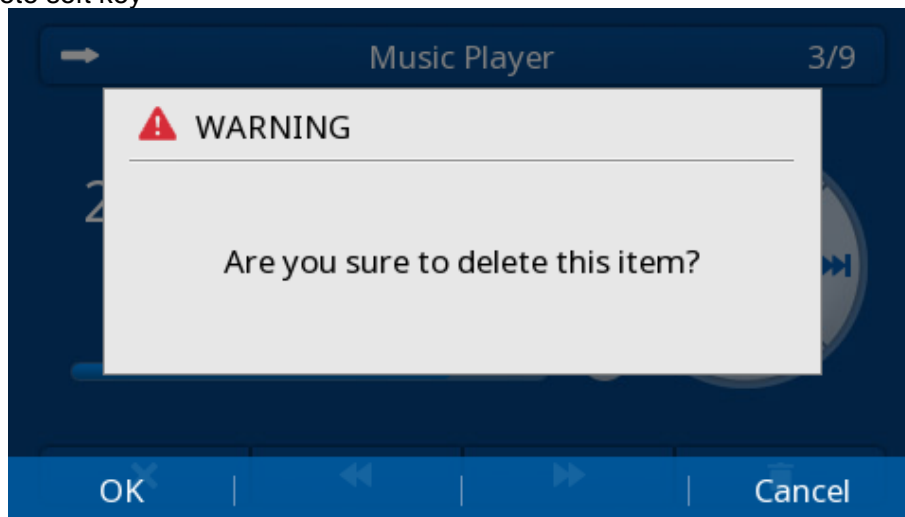

- Press OK soft key

You can also delete the recording that is playing:

- Press  soft key
- Press OK soft key

USB Headset

You can use a USB headset to handle calls on the phones.

After connecting a headset to your phone, you can activate the headset mode and use the headset when answering and placing calls. If you do not want to use a headset to handle calls, you can deactivate the headset mode.

Supported model: UC507U UC505U UC503U

To use a USB Headset:

1. Plug the headset into the USB port

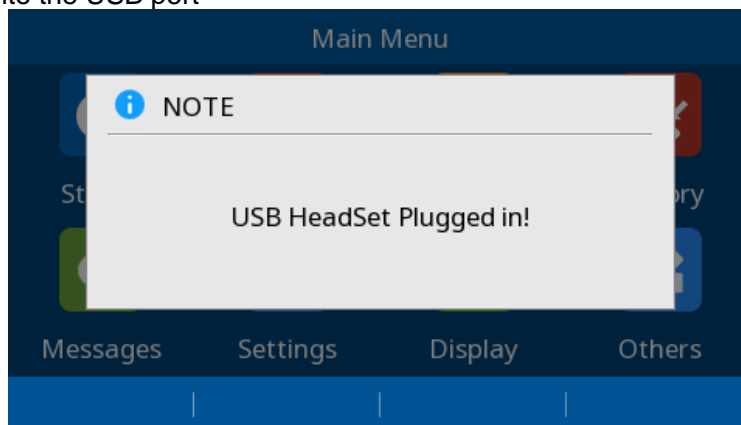

2. Press the headset key to open Headset mode
3. Press the headset key again to close Headset mode

For information on how to configure the headset mode, see [Headset Mode](#)

Adding a Wallpaper from a USB Flash Drive





You can use a picture that is stored on a USB flash drive as the wallpaper of your phone.

Make sure that the picture is in Browse photos directory of your USB flash drive, and the USB flash drive is connected to your phone successfully.

When you connect the USB flash drive successfully, the phone will pop up a note that U Disk Connected.

Supported model: UC507(U) UC505(U) UC503U

To add a wallpaper from a USB Flash Drive:

1. Press Menu soft key
2. Enter the USB app and select Browse photos
3. Press  and  to choose the picture and you can press  to view the pictures
4. Press Set As soft key
5. Press  and  to choose Wallpaper

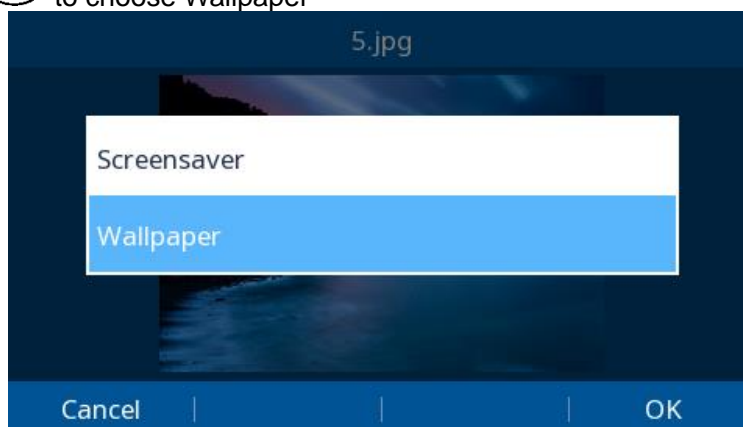

6. Press OK soft key
- The phone wallpaper will change to the selected picture

Note:

Photo size should be less than 100KB, name length should be less than 48.
You can only upload screen photos in format of '.bmp' and '.jpg'.



Adding a Screen Saver from a USB Flash Driver

You can use a picture that is stored on a USB flash drive as the screen saver of your phone. Make sure the USB flash drive is connected to your phone successfully.

When you connect the USB flash drive successfully, the phone will pop up a note that U Disk Connected.

Supported model: UC507(U) UC505U UC503U

To add a screen saver from a USB Flash Drive:

1. Press Menu soft key
2. Enter the USB app and select Browse photos
3. Press  and  to choose the picture and you can press  to view the pictures
4. Press Set As soft key

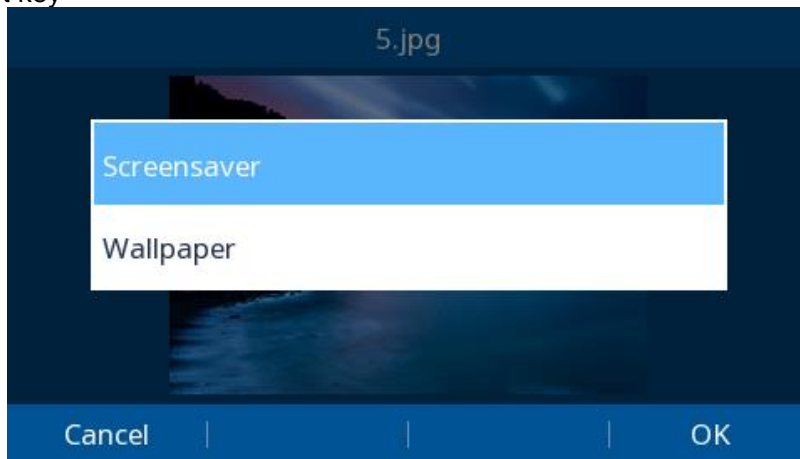

5. Press  and  to choose Screen Saver
6. Press OK soft key

The phone screen saver will change to the selected picture

Note:

Photo size should be less than 100KB, name length should be less than 48.
You can only upload screen photos in format of '.bmp' and '.jpg'.

Bluetooth

IP Phone Model **UC507U UC507 UC503E** support the Bluetooth feature.

How to Activate Bluetooth?

To activate Bluetooth via Phone interface:

1. Find Menu then navigate as follows:
Menu->Settings->Basic Setting->Bluetooth:

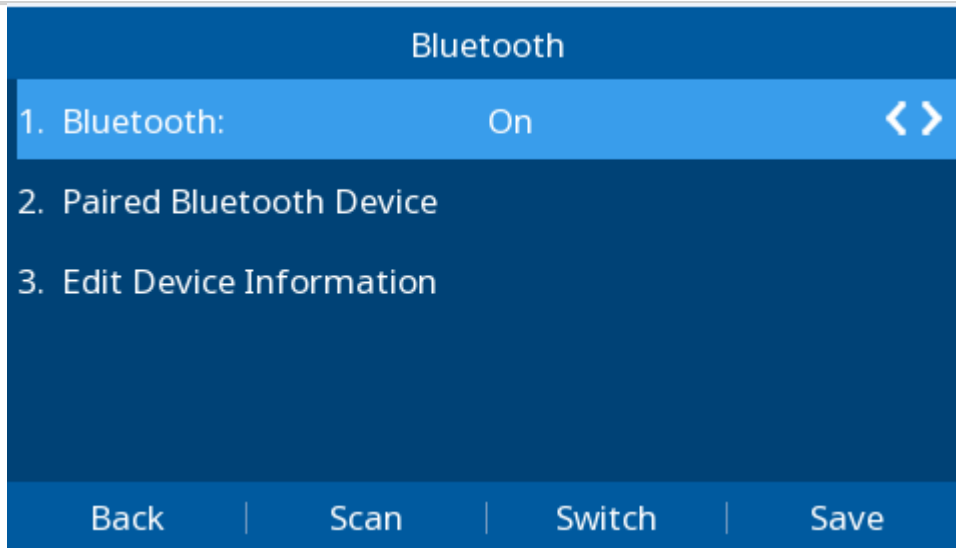

2. Press the save soft key to save the configuration.

3. You will see the Bluetooth icon on phone's homepage status bar during the idle status.
(This icon means that phone has no pair the Bluetooth device)

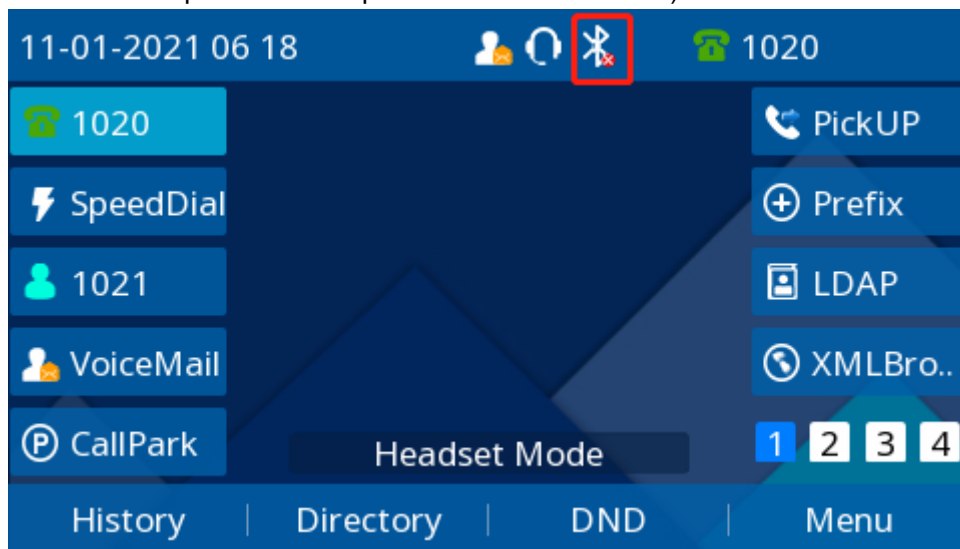

How to Pair the Bluetooth Headset to the Phone?

Open the Bluetooth pairing mode on Bluetooth headset:

1. Turn on the Bluetooth headset.
2. Long press the multifunction key on the Bluetooth headset until the indicator LED alternately flashes red and blue.

The Bluetooth headset is in pairing mode.

How to scan the Bluetooth headset device on phone interface:

1. Select "Paired Bluetooth Device". Press the "Scan" button on phone interface:

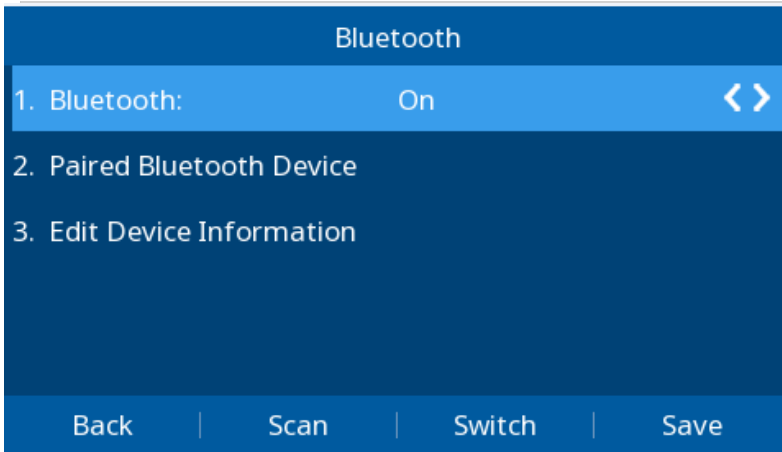

2. The phone will enter the scan interface, the phone starts searching for Bluetooth headsets within the working range of 10 meters (32 feet).

3. All detected Bluetooth headsets will display on the phone:

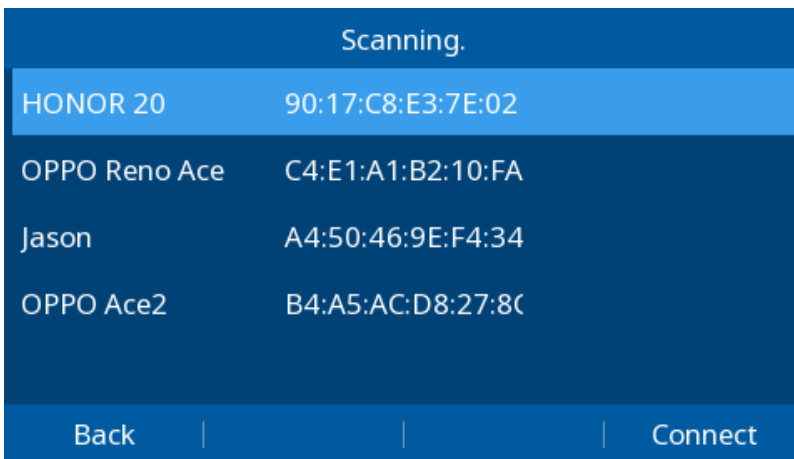

4. Choose the desired Bluetooth Device from the list and connect to it:

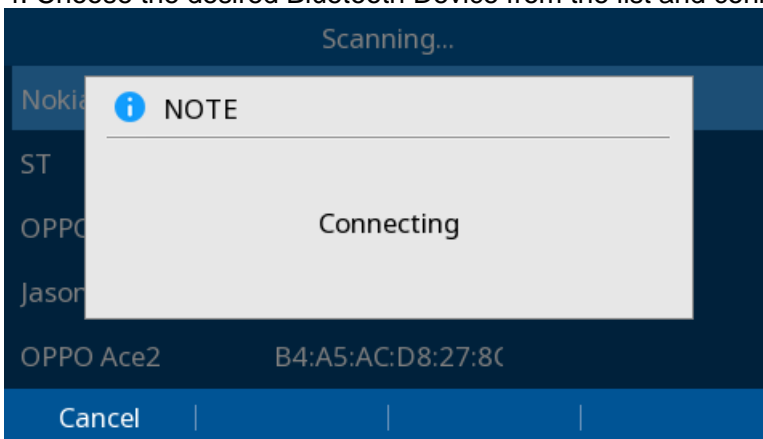

5. If the Bluetooth Device is connected/paired successfully, you will see the “Connect Success!” and successfully connected icon.

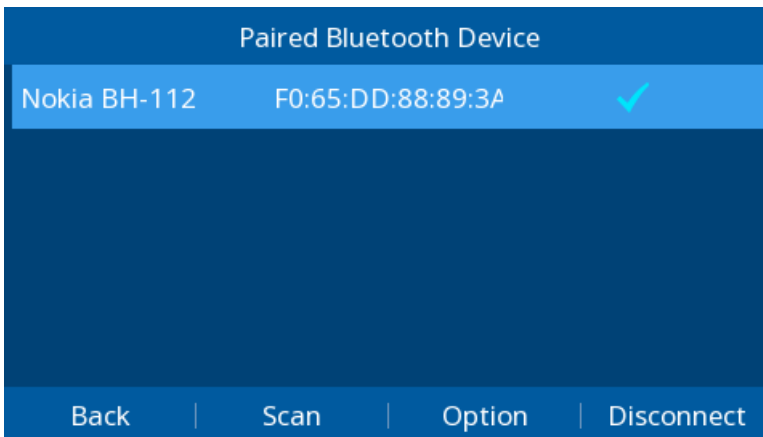
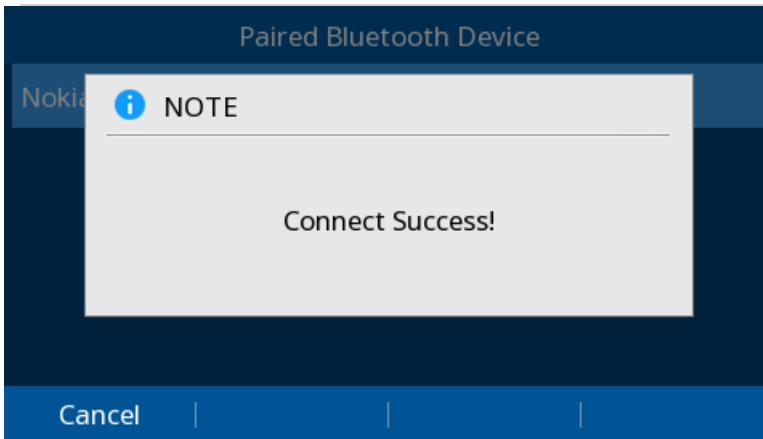

6. If you want to disconnect with this Bluetooth device, you can press the “Enter” button, then press the “Disconnect” button.

7. When you back to idle interface, you will see the connected successfully icon:

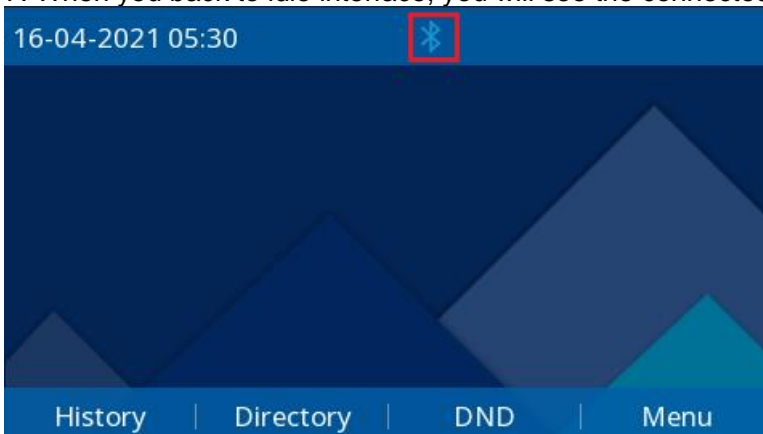

How to edit device information?

How to edit device information on phone interface:

1. Find Menu then navigate as follows:
Menu->Settings->Basic Setting->Bluetooth: Edit Device Information.

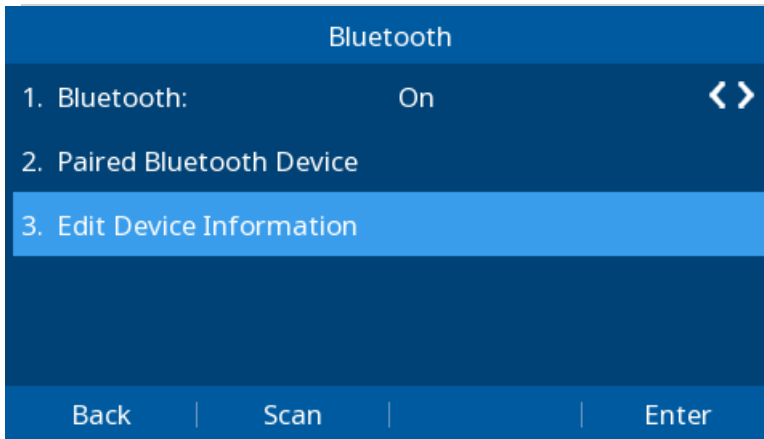

2. Press the enter button, you can edit the Device Name:

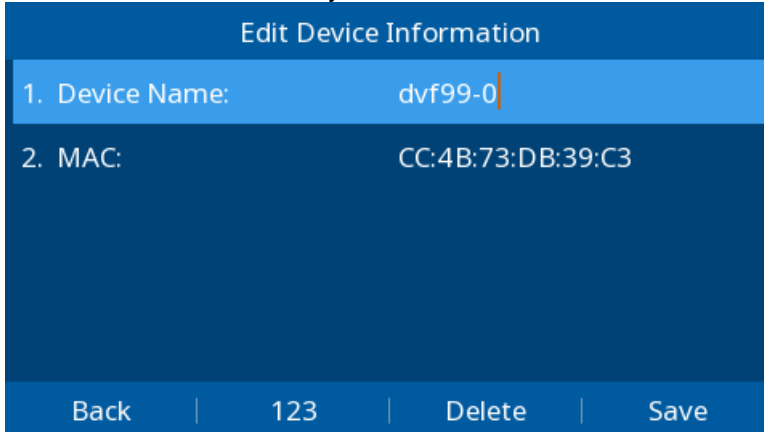

Note:

The phone must be in the headphone mode to normally use the Bluetooth function.

How to answer an incoming call?

With the Bluetooth headset paired, press the multifunction key on the Bluetooth headset to answer an incoming call.

How to adjust the earphone volume during a call?

With the Bluetooth headset paired, you can do the following:

- Press the Volume key (+) on the Bluetooth headset to increase the volume. Press the Volume key (-) on the Bluetooth headset to decrease the volume.
- Press the Volume key (+) on the phone to increase the volume. Press the Volume key (-) on the phone to decrease the volume.

How to End Call?

To end a call:

With the Bluetooth headset paired, press the multifunction key on the Bluetooth headset to end a call.

Wi-Fi

UC507U UC507 UC503E support Wi-Fi function which allows users to experience the flexible deployment. When the Wi-Fi feature is enabled, the IP phone will automatically scan the available wireless networks. All the available wireless networks will display in scanning list on the LCD screen.

The Wi-Fi feature can be configured in two different ways: Manual and Provision.

How to Enable Wi-Fi feature?

Enabling Wi-Fi feature via Phone interface:

1. Find Menu then navigate as follows Menu->Settings->Basic Setting->Wi-Fi. Press the Switch button.

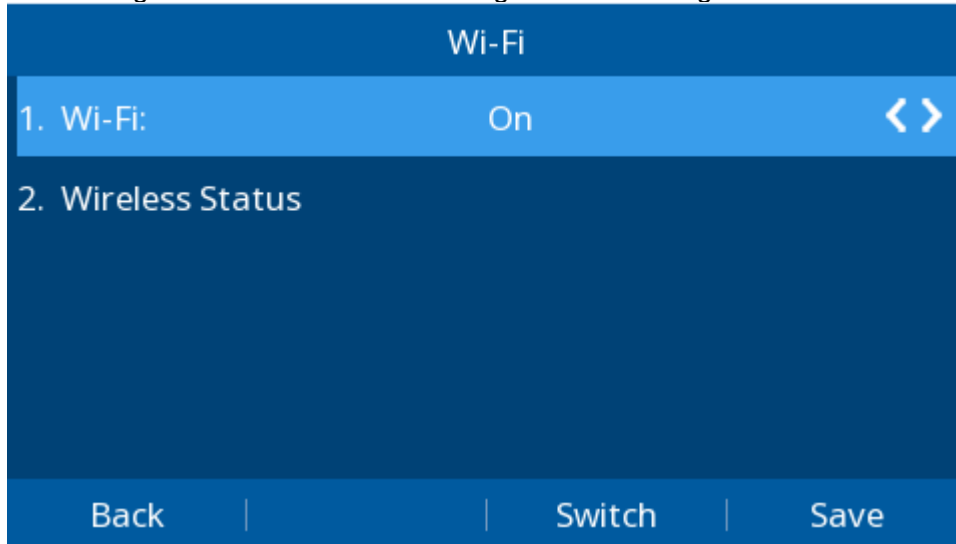

2. Press the Save soft key.

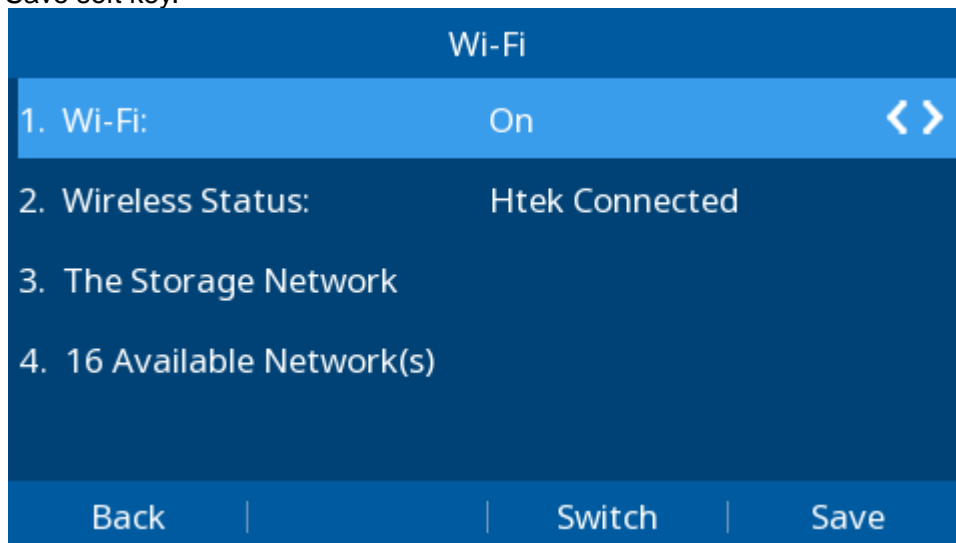

How to Connect an Available Wireless Network?

Connect to an available wireless network via Phone interface:

1. Find Menu then navigate as follows:
Menu->Settings->Basic Setting->Wi-Fi: Available Network(s)

2. Press the Enter button, you will see many available wireless networks:

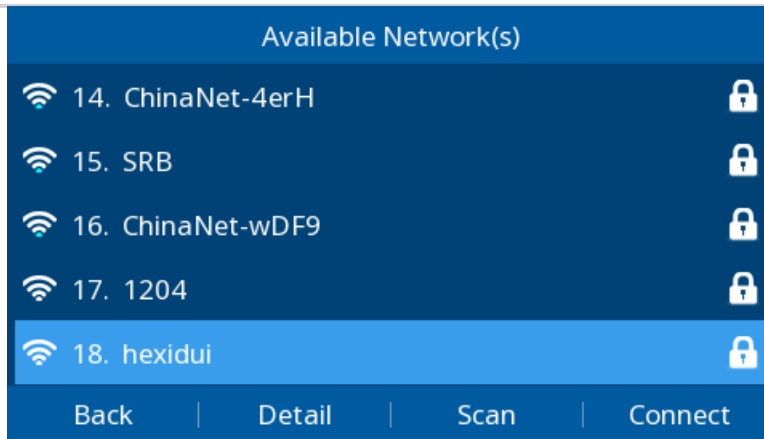

- 3. You can press the “scan” button to scan the wireless network.
- 4. You can press the “Detail” button to view a wireless network’s detail information.
- 5. Choose desired wireless network and then press the “Connect” button:

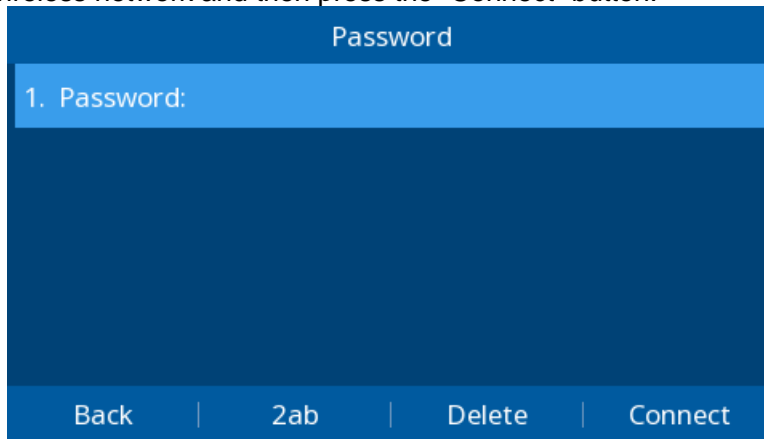

- 6. You must enter the wireless network’s password:

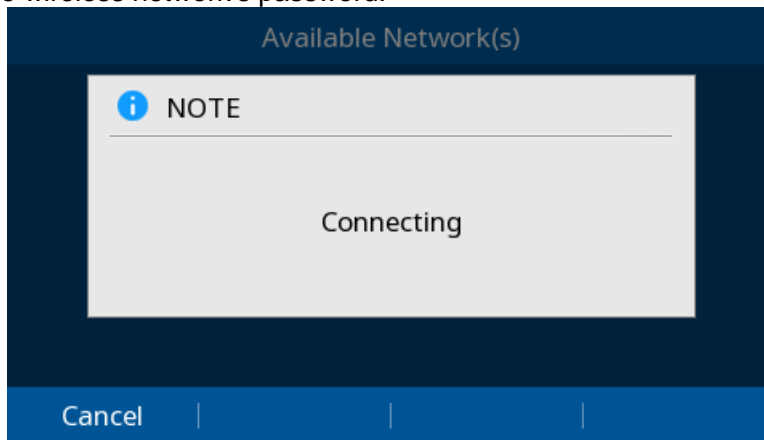

- 7. If the wireless network’s password is correct, the wireless network will connect successfully:

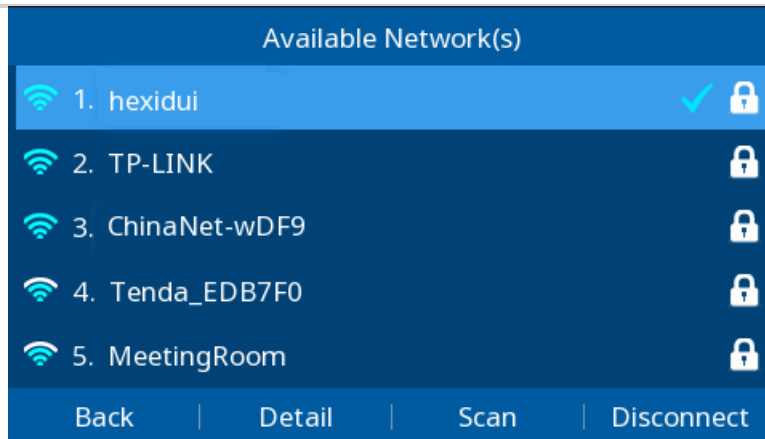

How to view Wireless Network status?

1. You will see the wireless network successfully connected icon when phone connects wireless network successfully and back to idle interface:

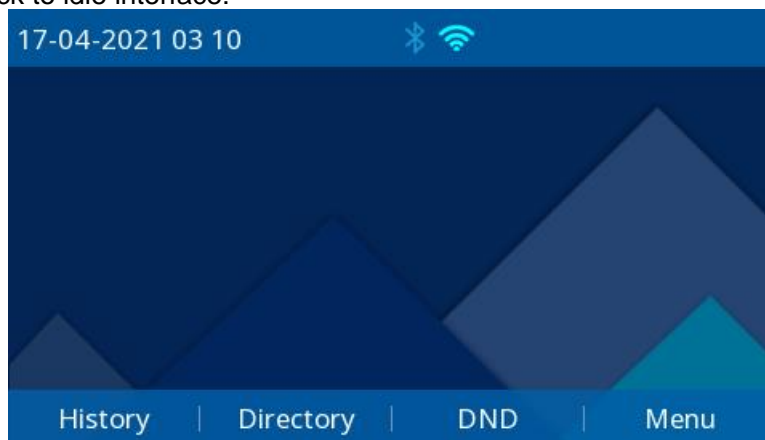

2. You can see the wireless network's detail information as follow: Menu->Status->Information:

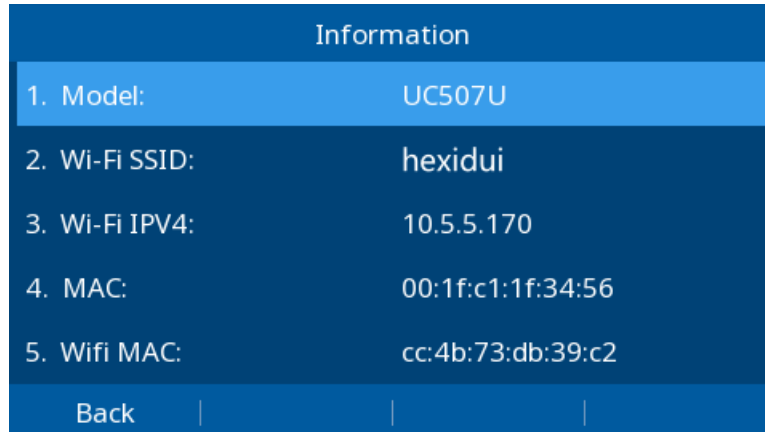

Or as follow:
Menu->Settings->Basic Setting->Wi-Fi: wireless status:

How to Disconnect Wireless Network?

Disconnect wireless network via Phone interface:

1. Enter Menu->Settings->Basic Setting->Wi-Fi: The Storage Network
2. Select the current connected Wi-Fi.
3. Press Disconnect Soft key.

How to Manually add a Wireless Network?

Add a Wireless Network Manually via Phone interface:

1. Enter Menu->Settings->Basic Setting->Wi-Fi: The Storage Network.
2. Press the “Add” button and then complete the fields:

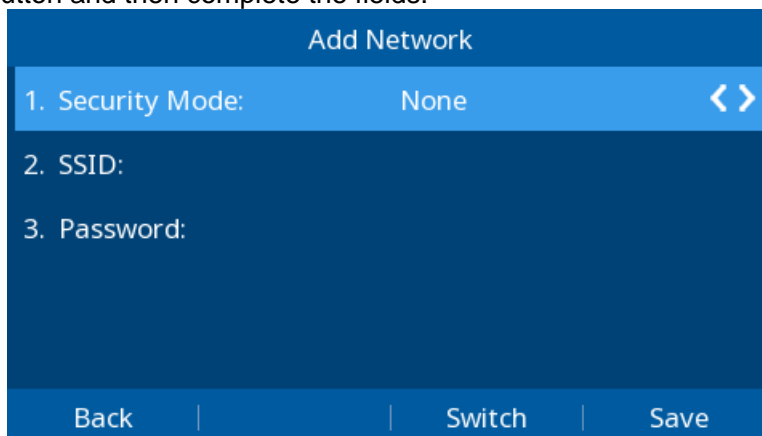

Select a Security Mode

Enter the desired wireless network (SSID)

If the wireless network is secure, please enter its password in the password field.

3. Press the “Save” button, and then you can choose this wireless network to connect it.

How to Disable Wi-Fi feature?

To disable the Wi-Fi feature via Phone interface:

1. Find Menu then navigate as follows Menu->Settings->Basic Setting->Wi-Fi:
2. Press the Switch button to turn off Wi-Fi feature.
3. Press the Save button to save the configuration.

Function Key

The function key supports the **Line Label Length**, **Line Page Indicator**, **BLF list MODE**, **BLF blink**.

Line Label Length: If this option is set Long label, then the label’s length will be longer, it is used if the string is too long.

Line Page Indicator: Enable this option when the IP Phone has been configured for multiple pages. For example, when current page is the first page, the second page has a BLF and BLF’s status is changed, the second page’s button will flash the red indicator.

BLF list MODE: You can configure the line key as BLF List manually, automatically, or automatically to the expansion.

BLF blink: Turn this option on to make the BLF key blink when the monitored extension is ringing or talking.

Line Keys

Line

Key type Line supports two modes: Default and Lock.

Default mode: Line Key will only be displayed on the configured page and will not automatically jump to incoming calls.



Lock mode: The line key will reflect on the same position on every page when the line key is set as the Line type.

If set to Lock Mode, the DSSKey at the corresponding location will be locked (not configurable).

Line	Type	Mode	Value	Label	Account	Extension
Key1	Line	Lock		025	Account 1	
Key2	BLF	Default	136		Account 1	
Key3	BLF	Default	137		Account 1	
Key4	Speed Dial	Default	136		Account 1	
Key5	Voice Mail	Default	999		Account 1	
Key6	Direct Pickup	Default	*20*		Account 1	
Key7	Prefix	Default	1		Account 1	
Key8	LDAP	Default			Account 1	
Key9	ACD	Default			Account 1	
Key10	URL	Default	443		Account 1	
Key11	N/A	Default			Account 1	
Key12	N/A	Default			Account 1	
Key13	N/A	Default			Account 1	
Key14	N/A	Default			Account 1	
Key15	N/A	Default			Account 1	

To configure Line feature via phone interface

1. Press Menu → Features → Function → Line → Line Key1 (for example)

2. Press  and  key to select the Line in the Type field.

3. Select the Account ID.

4. Press  or Save soft key to save the configuration.
Then the selected Line Key will work as Line.

To configure Line Feature via Web interface

1. Click Function Keys → Line Key.

2. Select the wanted Line Key and set as Line.

3. Select the Account.

4. Click the  button to save the configuration.



Line	Type	Mode	Value	Label	Account	Extension
Key1	Line	Default		025	Account 1	
Key2	BLF	Default	136		Account 1	
Key3	BLF	Default	137		Account 1	

Speed Dial

With this feature, you can dial one number by pressing the configured Speed Dial key.

To configure Speed Dial feature via Phone interface

1. Press Menu→ Features→ Function Keys→ Line keys as Function Keys→ Line Key2(for example)

- Press  and  key to select the Speed Dial in the Type field.
- Enter the targeted Number in the Value field.
- Select the Account ID.

5. Press  or Save soft key to save the configuration.
Then the selected Line Key will work as Speed Dial.

To configure Speed Dial feature via Web interface

- Click Function Keys→ Line Key.
- Select the wanted Line Key and set as Speed Dial.
- Enter the desired phone number in the Value field.
- Select the Account
- Click the  button to save the configuration.

Line	Type	Mode	Value	Label	Account	Extension
Key1	Line	Default		243	Account 1	
Key2	Speed Dial	Default	245		Account 1	





BLF

You can use the BLF (Busy Lamp Field) feature to monitor a specific extension number whether the extension is busy or free.

- When the extension you are monitoring is idle, the light is steady green.
- When the monitored extension is ringing, the light is blinking red, press the BLF key to pick the IP Phone up directly.
- When the monitored extension is calling or in a conversation, the light is steady red.

To configure a BLF key via phone interface

1. Press Menu→ Features→ Function→ Line Keys as Function Key → Line Key1(for example).

- Press  and  key to select the BLF in the Type field.
- Enter the targeted Number in the Value field.
- Press  and  key to select the Account ID.
- Enter the Pickup Code.
- Press  or Save soft key to save the configuration.

To configure a BLF key via Web interface

1. Click Function Keys→ Line Key.
2. Select the desired Line Key and select BLF in the Type field.
3. Enter the monitored phone number in the Value field.
4. Select the Account.
5. Fill in the Extension.
6. Click to save the configuration.

Line	Type	Mode	Value	Label	Account	Extension
Key1	Line	Default		025	Account 1	
Key2	BLF	Default	136		Account 1	

DTMF

When the key is configured as DTMF key, you can send out the desired DTMF number during the conversation.



To use this feature, you should sure that the DTMF Tone is on.

To configure the DTMF Tone via Web interface

1. Click Setting→ Preference
2. Select On for Keypad DTMF Tone.
3. Click to save the configuration.

Keypad DTMF Tone On Off

To configure the DTMF via Phone interface

1. Press Menu→ Features→ Function Keys→ Line Keys as Function Keys→ Line Key2(for example)
2. Press  and  key to select the DTMF in the Type field.
3. Enter the Value field with the desired DTMF number.
4. Press  or Save soft key to save the configuration.

To configure the DTMF via Web interface



1. Click Function Keys→ Line Key.
2. Select the desired Line Key and select DTMF in the Type field.
3. Fill in the Value field with the desired DTMF number.
4. Click the to save the configuration.

Line	Type	Mode	Value	Label	Account	Extension
Key1	Line	Default		243	Account 1	
Key2	DTMF	Default	0012		Account 1	

Prefix

If the key is configured as Prefix key, you can set the number prefix (e.g. Before the number plus 9), then you don't input 9, press the key and 9 will display on the LCD interface.

To configure the Prefix via Phone interface

1. Press Menu→ Features→ Function Keys→ Line Keys as Function Keys→ Line Key2(for example)
2. Press  and  key to select the Prefix in the Type field.
3. Enter the value field with number that you want to set as prefix.
4. Press  or save soft key to save the configuration.

To configure the Prefix via Web interface:

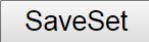

1. Click Function Keys→ Line Key.
 2. Select the desired Line Key and select Prefix in the Type field.
 3. Fill in the value field with number that you want to set as prefix.
 4. Click  to save the configuration.
- Then when you press this key, the set value is input directly.

Line	Type	Mode	Value	Label	Account	Extension
Key1	Line	Default		243	Account 1	
Key2	Prefix	Default	9		Account 1	

Local Group

When use the Local Group feature, press the key and enter the Local Contacts interface quickly.

To configure the Local Group via Phone interface

1. Press Menu→ Features→ Function Keys→ Line Keys as Function Keys→ Line Key2(for example)
2. Press  and  key to select the Local Group in the Type field.
3. Press  or Save soft key to save the configuration.

To configure the Local Group via Web interface





1. Click Function Keys→ Line Key.
 2. Select the desired Line Key and select Local Group in the Type field.
 3. Click  to save the configuration.
- Then you can press the Local Group key to quickly enter the Local Contacts interface.

Line	Type	Mode	Value	Label	Account	Extension
Key1	Line	Default		243	Account 1	
Key2	Local Group	Default			Account 1	

XML Group

When use the XML Group feature, press the key and enter the Remote Contacts interface quickly.

To configure the XML group via Phone interface

1. Press Menu→ Features→ Function→ Line Keys as Function Key→ Line Key2(for example)
2. Press  and  key to select the XML Group in the Type field.
3. Press  and  key to select the Account ID.
4. Press  or Save soft key to save the configuration.

To configure the XML Group via Web interface



1. Click Function Keys→ Line Key.
2. Select the desired Line Key and select XML Group in the Type field.
3. Select the desired remote phonebook in the Account field.
4. Click  to save the configuration.

Line	Type	Mode	Value	Label	Account	Extension
Key1	Line	Default		243	Account 1	
Key2	XML Group	Default			remote pho	

XML Browser

You can use this key to access the Xml browser quickly. The Xml browser allows you to create custom services which meet your functional requirements on the server. You can customize practical applications, such as weather report, stock information, Google search, etc.

To configure the XML Browser via Phone interface

1. Press Menu→ Features→ Function Keys→ Line Keys as Function Keys→ Line Key2(for example)
2. Press  and  key to select the XML Browser in the Type field.
3. Fill in the access URL for xml browser in the Value field.
4. Press  or Save soft key to save the configuration.

To configure the XML Browser via Web interface





1. Click Function Keys→ Line Key.
2. Select the desired Line Key and select Xml Browser in the Type field.
3. Fill in the access URL for xml browser in the Value field. (e.g.: <http://10.2.0.140/XMLBrowser/TextMenu.xml>)
4. Click  button to save the configuration.

Line	Type	Mode	Value	Label	Account	Extension
Key1	Line	Default		243	Account 1	
Key2	XML Browser	Default	http://10.2.0		Account 1	

Network Directories

When using the BroadSoft Directory feature, by just pressing the key you can enter the Broadsoft Contacts interface its fast and convenient.

To configure the Network Directories via Phone interface

1. Press Menu→ Features→ Function Keys→ Line Keys as Function Keys→ Line Key2(for example)
2. Press  and  key to select the BS Group in the Type field.
3. Press  and  key to select the Account ID.
4. Press  or Save soft key to save the configuration.

To configure the Network Directories via Web interface

1. Click Function Keys→ Line Key.
2. Select the desired Line Key and select Network Directories in the Type field.
3. Select the Account.
4. Click the  button to save the configuration.

Line	Type	Mode	Value	Label	Account	Extension
Key1	Line	Default		243	Account 1	
Key2	Network Direct	Default			Account 1	

Then you can press the Network Directories key to quickly enter the Broadsoft Contacts interface.

To configure the Network Group via Web interface

1. Click Function Keys→ Line Key.
2. Select the desired Line Key and select Network Group in the Type field.
3. Select All Contacts/Group/Interoperability/GroupCommon/EnterpriseCommon/Personal/Custom Directories for the Account.
4. Click the  button to save the configuration.



Line	Type	Mode	Value	Label	Account	Extension
Key1	Line	Default		243	Account 1	
Key2	Network Group	Default			All Contact	

Then you can press the Network Group key to quickly enter the selected secondary directory of Broadsoft Contacts.

Conference

The IP Phone supports up to 5-way conference. You can configure the line key to be used as a conference key.

To configure the Conference via Phone interface

1. Press Menu→ Features→ Function Keys→ Line Keys as Function Keys→ Line Key2(for example)
2. Press  and  key to select the Conference in the Type field.

3. Press  or save soft key to save the configuration.

To configure Conference via Web interface

1. Click Function Keys→ Line Key.
2. Select the desired Line Key and select Conference in the Type field.
3. Click the  button to save the configuration.

Line	Type	Mode	Value	Label	Account	Extension
Key1	Line	Default		243	Account 1	
Key2	Conference	Default			Account 1	

Forward

1. If the Forward Key has no configuration value, press it to enter the Always Forward configuration page.

Always Forward

1. Always:
Disable
< >



2. Forward to:

Back
Switch
Save

2. If the forward key is configured with a value, please press this key to always turn it on, and this notification message will be displayed on the phone LCD. Press the forward key again to turn off this function. At this time, there is an incoming call, which can be dynamically forward.

To configure the Forward via Phone interface

1. Press Menu→ Features→ Function Keys→ Line Keys as Function Keys→ Line Key2(for example)

2. Press  and  key to select the Forward in the Type field.
3. Enter the Number to forward to in the Value field.
4. Press  or Save soft key to save the configuration.

To configure Forward via Web interface

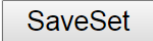
1. Click Function Keys→ Line Key.
2. Select the desired Line Key and select Forward in the Type field.
3. Enter the Value field with the number you want to forward to.
4. Click the  button to save the configuration.



Line	Type	Mode	Value	Label	Account	Extension
Key1	Line	Default		243	Account 1	
Key2	Forward	Default	245		Account 1	

Transfer

1. If the Transfer Key is configured with a value, then transfer will be executed directly, and it is related to [Transfer Mode via DSSKey](#).
2. If Transfer Key has no configuration value, it will be used as Transfer Softkey.

To configure the Transfer via Phone interface

1. Press Menu→ Features→ Function Keys→ Line Keys as Function Keys→ Line Key2(for example)

2. Press  and  key to select the Transfer in the Type field.
3. Enter the Number to transfer to in the Value field.
4. Press  or Save soft key to save the configuration.

To configure Transfer via Web interface



1. Click Function Keys→ Line Key.
2. Select the desired Line Key and select Transfer in the Type field.
3. Enter the Value field with the number that wanted transfer to
4. Click the  button to save the configuration.

Line	Type	Mode	Value	Label	Account	Extension
Key1	Line	Default		243	Account 1	
Key2	Transfer	Default	245		Account 1	

Hold

The key can be configured as a hold key. You can use this key to hold and resume a call during the conversation.

To configure the Hold via Phone interface

1. Press Menu→ Features→ Function Keys→ Line Keys as Function Keys→ Line Key2(for example)
2. Press  and  key to select the Hold in the Type field.
3. Press  or Save soft key to save the configuration.

To configure the Hold via Web interface

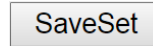
1. Click Function Keys→ Line Key.
2. Select the desired Line Key and select Hold in the Type field.
3. Click the  button to save the configuration.

Line	Type	Mode	Value	Label	Account	Extension
Key1	Line	Default		243	Account 1	
Key2	Hold	Default			Account 1	

DND

If the key is configured as DND key, allows you to activate the DND function immediately when you press it and the phone will reject all incoming calls automatically. Press it again to deactivate DND mode.

To configure the DND via Phone interface

1. Press Menu→ Features→ Function Keys→ Line Keys as Function Keys→ Line Key2(for example)

2. Press  and  key to select the DND in the Type field.

3. Press  or Save soft key to save the configuration.

To configure DND via Web interface

1. Click Function Keys→ Line Key.

2. Select the desired Line Key and select DND in the Type field.

3. Click the  button to save the configuration.

Line	Type	Mode	Value	Label	Account	Extension
Key1	Line	Default		243	Account 1	
Key2	DND	Default			Account 1	

To enable DND feature

Press the DND key when the phone is idle status, and then DND icon is shown on the LCD.

To disable DND feature

Press the DND key again, then there is no DND icon on the LCD.

Redial

If the key is configured as Redial key, you can redial the last placed call from the IP Phone.

To configure Redial via Phone interface

1. Press Menu→ Features→ Function Keys→ Line Keys as Function Keys→ Line Key2(for example)

2. Press  and  key to select the Redial in the Type field.

3. Press  or Save soft key to save the configuration

To configure Redial via Web interface

1. Click Function Keys→ Line Key

2. Select the desired Line Key and select Redial in the Type field.

3. Click the  button to save the configuration.

Line	Type	Mode	Value	Label	Account	Extension
Key1	Line	Default		243	Account 1	
Key2	Redial	Default			Account 1	

Record

With record feature, you can record your calls by pressing the record key.

To configure the Record via Phone interface

1. Press Menu→ Features→ Function Keys→ Line Keys as Function Keys→ Line Key2(for example)

2. Press  and  key to select the Record in the Type field.

3. Press  or Save soft key to save the configuration.

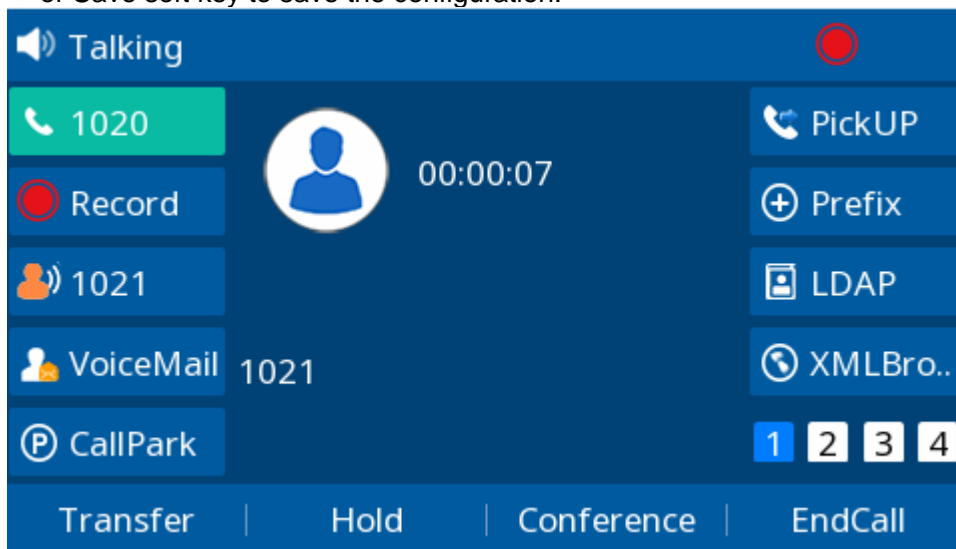

To configure the Record via Web interface

1. Click Function Keys→ Line Key.

2. Select the desired Line Key and select Record in the Type field.

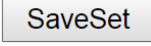
3. Click the  button to save the configuration.

[logout](#)

IP PHONE Home | Profile | Account | Network | **Function Keys** | Setting | Directory | Management

Line Key

Programmable Key

EXP KEY

Line Label Length: Default

BLF list MODE: Manually

BLF blink: Off

Line Page Indicator: Disable

line key as cancel: Disable

Line	Type	Mode	Value	Label	Account	Extension
Key1	Line	Lock			Account 1	
Key2	Record	Default			Account 1	

NOTE



Note:

Please contact the system administrator whether support this feature or not.

URL Record

The phone sends HTTP URL request to trigger a recording. Contact your system administrator for the predefined URL.

To configure the URL Record via Phone interface

1. Press Menu→ Features→ Function Keys→ Line Keys as Function Keys→ Line Key2(for example)
2. Press  and  key to select the URL Record in the Type field.
3. Enter the predefined URL in the Value field.
4. Press  or Save soft key to save the configuration.

To configure the URL Record via Web interface

1. Click Function Keys→ Line Key.
2. Select the desired Line Key and select URL Record in the Type field.
3. Fill in the predefined URL in the Value field.
4. Click the  button to save the configuration.

Line	Type	Mode	Value	Label	Account	Extension
Key1	Line	Default		243	Account 1	
Key2	URL Record	Default	http://10.2.0		Account 1	





Note:

Please contact the system administrator whether support this feature or not.

Paging

With this feature, you can call a paging group directly.

To configure the Paging via Phone interface

1. Press Menu→ Features→ Function Keys→ Line Keys as Function Keys→ Line Key2(for example)
2. Press  and  key to select the Paging in the Type field.
3. Enter the paging code followed the number in the Value field.
4. Press  and  key to select the Account ID.
5. Press  or Save soft key to save the configuration.

To configure the Paging via Web interface

1. Click Function Keys→ Line Key.
2. Select the desired Line Key and select Paging in the Type field.
3. Enter the paging code followed the number in the Value field.
4. Select the Account.
5. Click the  button to save the configuration.

Line	Type	Mode	Value	Label	Account	Extension
Key1	Line	Default		243	Account 1	
Key2	Paging	Default	*88039		Account 2	

Note:



Please contact the system administrator whether support this feature or not.

Group Listening

With this feature, when you have an active call, you can listen using Handset and speakerphone, but only can use the handset to speak.

To configure the Group Listening via Phone interface

1. Press Menu→ Features→ Function Keys→ Line Keys as Function Keys→ Line Key2(for example)

2. Press  and  key to select the Group Listening in the Type field.
3. Press  or Save soft key to save the configuration.

To configure the Group Listening via Web interface

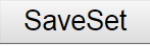
1. Click Function Keys→ Line Key.
2. Select the desired Line Key and select Group Listening in the Type field.
3. Click  to save the configuration.



Line	Type	Mode	Value	Label	Account	Extension
Key1	Line	Default		243	Account 1	
Key2	Group Listenin	Default			Account 1	

Public Hold

The key can be configured as a public hold key. During a conversation, all members belonging to that SLA group can use this key to hold or resume a call.

To configure the Public Hold via Phone interface

1. Press Menu→ Features→ Function Keys→ Line Keys as Function Keys→ Line Key2(for example)

2. Press  and  key to select the Public Hold in the Type field.
3. Press  or Save soft key to save the configuration.

To configure the Public Hold via Web interface

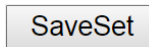
1. Click Function Keys→ Line Key.
2. Select the desired Line Key and select Public Hold in the Type field.
3. Click the  button to save the configuration.

Line	Type	Mode	Value	Label	Account	Extension
Key1	Line	Default		243	Account 1	
Key2	Public Hold	Default			Account 1	

Note:



Please contact the system administrator whether support this feature or not.

Private Hold

The key can be configured as a private hold key. During a conversation, all members belonging to that particular SLA group can use this key to hold the call, but only the initiator can resume the call.

To configure the Private Hold via Phone interface

1. Press Menu→ Features→ Function Keys→ Line Keys as Function Keys→ Line Key2(for example)

2. Press  and  key to select the Private Hold in the Type field.

3. Press  or Save soft key to save the configuration.

To configure the Private Hold via Web interface

1. Click Function Keys→ Line Key.

2. Select the desired Line Key and select Private Hold in the Type field.

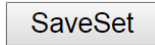
3. Click the  button to save the configuration.

Line	Type	Mode	Value	Label	Account	Extension
Key1	Line	Default		243	Account 1	
Key2	Private Hold	Default			Account 1	

Note:



Please contact the system administrator whether support this feature or not.

Zero Touch

You can use this key feature to configure auto provision and network parameters quickly.

To configure the Zero Touch via Phone interface

1. Press Menu→ Features→ Function Keys→ Line Keys as Function Keys→ Line Key2(for example)

2. Press  and  key to select the Zero Touch in the Type field.

3. Press  or Save soft key to save the configuration.

To configure the Zero Touch via Web interface:

1. Click Function Keys→ Line Key.

2. Select the desired Line Key and select Zero Touch in the Type field.

3. Click the **SaveSet** button to save the configuration.

Line	Type	Mode	Value	Label	Account	Extension
Key1	Line	Default		243	Account 1	
Key2	Zero Touch	Default			Account 1	

To use the zero touch feature on the user interface:

1. Press the Zero Touch key when the IP Phone is idle.
2. Press the OK soft key and the IP Phone will enter the WAN Port interface; you can change the WAN Type by pressing the Navigation keys.
3. Press the Next soft key to enter Network interface, then you can configure some information.
4. Press the Next soft key again, you can configure Auto Provision information.
5. When you finish the setting, you can press the OK to accept the changes.

Note:



This feature is not available on all servers. For more information, contact your system administrator.

Multicast Paging

You can use multicast paging to forward out time sensitive announcements quickly and easily to people within the multicast group. You can configure a multicast paging key or a paging list key on the phone, which allows you to send a Real Time Transport Protocol (RTP) stream to the pre-configured multicast address/addresses without involving SIP signaling. You can configure the phone to receive an RTP stream from pre-configured multicast listening address/addresses without involving SIP signaling. You can specify up to 10 multicast listening addresses.

21. Sending RTP Stream

To configure a Multicast Paging key via Phone interface

1. Press Menu→ Features→ Function Keys→ Line Keys as Function Keys→ Line Key2(for example).
2. Press  and  or Switch soft key to select the Multicast Paging in the Type field.
3. Enter the multicast IP address and port number (e.g., 224.5.6.20:2000) in the Value field. The valid multicast IP addresses range from 224.0.0.0 to 239.255.255.255.
4. Press  or Save soft key to save the configuration.

To configure a Multicast Paging key via Web interface

1. Click Function Keys→ Line key:
2. Select the desired Line Key and select Multicast Paging in the Type field.
3. Enter the multicast IP address and port number (e.g., 224.5.6.20:2000) in the Value field. The valid multicast IP addresses range from 224.0.0.0 to 239.255.255.255.
4. Click the **SaveSet** button to save the configuration.

Line	Type	Mode	Value	Label	Account	Extension
Key1	Line	Default		243	Account 1	
Key2	MultiCast Pagi	Default	224.5.6.20:2		Account 1	

Sending RTP Stream:

Press the Multicast Paging key when the phone is idle.

The phone sends RTP to a preconfigured multicast address (IP: Port). Any phone in the local network then listens to the RTP on the preconfigured multicast address (IP: Port). For both sending and receiving of the multicast RTP, there is no SIP signaling involved.

The Multicast Paging key LED will be solid green.

22. Receiving RTP Stream

You can configure the phone to receive a Real Time Transport Protocol (RTP) stream from the pre-configured multicast address/addresses without involving SIP signaling. You can specify up to 10 multicast addresses that the phone listens to on the network.

How the phone handles incoming multicast paging calls depends on Paging Barge and Paging Priority Active parameters configured via web user interface.

Paging Barge

The paging barge parameter defines the priority of the voice call in progress. If the priority of an incoming multicast paging call is lower than that of the active call, it will be ignored automatically. If Disabled is selected from the pull-down list of Paging Barge, the voice call in progress will take precedence over all incoming multicast paging calls.

Valid values in the Paging Barge field:

- 1 to 10: Define the priority of the active call, 1 with the highest priority, 10 with the lowest.
- Disabled: The voice call in progress will take precedence over all incoming paging calls.

Paging Priority Active

The paging priority active parameter decides how the phone handles incoming multicast paging calls when there is already a multicast paging call on the phone. If enabled, the phone will ignore incoming multicast paging calls with lower priorities, otherwise, the phone will answer incoming multicast paging calls automatically and place the previous multicast paging call on hold. If disabled, the phone will automatically ignore all incoming multicast paging calls.

Multicast Codec

You can only configure the codec via Web interface.

To configure Multicast Codec via Web interface

1. Click Directory→ Multicast Paging
2. Select the desired codec from the pull-down list of Multicast Codec
3. Click the button to save the configuration.

Listening Address

To configure multicast listening addresses via Web interface:

1. Click Directory→ Multicast Paging.
2. Select the desired value from the pull-down list of Paging Barge.
3. Select the desired value from the pull-down list of Paging Priority Active.
4. Enter the multicast IP address and port number (e.g., 224.5.6.20:2000) which the phone listens to for incoming RTP multicast in the Listening Address field.
5. Enter the label in the Label field.
6. Click button to save the configuration.

Paging Barge

Paging Priority Active

Multicast Codec

Index	Listening Address	Label	Multi Priority
IP Address 1	<input type="text" value="224.5.6.20:2000"/>	<input type="text"/>	1
IP Address 2	<input type="text"/>	<input type="text"/>	2
IP Address 3	<input type="text"/>	<input type="text"/>	3
IP Address 4	<input type="text"/>	<input type="text"/>	4
IP Address 5	<input type="text"/>	<input type="text"/>	5
IP Address 6	<input type="text"/>	<input type="text"/>	6
IP Address 7	<input type="text"/>	<input type="text"/>	7
IP Address 8	<input type="text"/>	<input type="text"/>	8
IP Address 9	<input type="text"/>	<input type="text"/>	9
IP Address 10	<input type="text"/>	<input type="text"/>	10

Note:

The priorities of listening to multicasting addresses can be predefined: 1 being the highest priority, 10 with the lowest in priority order. Both the multicast paging sender and receiver's phones play a warning tone when establishing a multicast paging call. Listening to Multicasting addresses can be configurable via Web interface only.

Programmable Key

Soft Keys, Navigation Keys and Hard Keys are Programmable. You can define them as some other features rather than the default in idle status.

And please note that if the blank is gray, it means that the type is not editable.

Customizing the Soft Keys

You can customize the soft key functions displayed at the bottom of the phone screen.

These soft keys are usually used to access frequently used functions and create menu shortcuts to access frequently used phone settings.

To configure the soft keys via Web interface:

1. Click webpage →Function keys→ Programmable Key→ softkey.
2. Select the desired softkey(softkey1-4)
3. Select the desired key type from the Type field.
4. (Optional.) Enter the string that will appear on the phone screen in the label field.
5. (Optional.) Select the desired line from the Account ID field.
6. (Optional.) Enter the corresponding value in the Value field.
7. Click button to save the configuration.

The screenshot shows the 'IP PHONE' web interface. The top navigation bar includes 'Home | Profile | Account | Network | Function Keys | Setting | Directory | Management'. On the left, there are buttons for 'Line Key', 'Programmable Key', and 'EXP KEY'. The main content area features a table with columns: Key, Type, Label, Account, and Value. The table contains four rows for SoftKey1 through SoftKey4. A red box highlights the table. To the right of the table is a 'NOTE' section.

Key	Type	Label	Account	Value
SoftKey1	History		Account 1	
SoftKey2	Directory		Menu View	
SoftKey3	DND		Account 1	
SoftKey4	Menu		Account 1	

LCD display:

The screenshot shows the phone's LCD display. At the top, it displays the date and time '12-01-2021 01:05' and the number '1020'. Below this, there are several function buttons: '1020', 'Record', '1021', 'VoiceMail', 'CallPark', 'PickUP', 'Prefix', 'LDAP', 'XMLBro..', and a row of buttons labeled '1', '2', '3', '4'. At the bottom, there is a row of softkey buttons: 'History', 'Directory', 'DND', and 'Menu'. A red arrow points to the 'softkey' label above the 'Voice Mail 50 new' button, and a red box highlights the bottom row of softkey buttons.

Note:

We recommend that you keep a Menu soft key, otherwise you cannot access the phone settings.

Customizing the hard Keys

You can customize the hard keys on the phone, such as navigation keys, volume keys, voicemail, headset, mute, Speaker, conference, HOLD, transfer.

To configure the hard keys via Web interface:

1. Click webpage →Function keys →Programmable Key
2. Select the desired key.
3. Select the desired key type from the Type field.
4. (Optional.) Select the desired line from the Account ID field.
5. (Optional.) Enter the corresponding value in the Value field.

6. Click button to save the configuration.

Key	Type	Account	Value
Up	History	Account 1	
Down	Directory	Menu View	
Left	Switch Account Up	Account 1	
Right	Switch Account Down	Account 1	
OK	Status	Account 1	
Cancel	N/A	Account 1	
MUTE	N/A	Account 1	
CONF	N/A	Account 1	
TRAN	Forward	Account 1	
HOLD	N/A	Account 1	
Speaker	Speaker	Account 1	
Headset	Headset	Account 1	
VM	VM	Account 1	
Volume Up	Volume Up	Account 1	
Volume Down	Volume Down	Account 1	

Note:
We recommend that you keep a Menu soft key, otherwise you cannot access the phone settings.

Exp Key

When the extension module is turned on, the configuration items will be displayed(Only **UC507U** support).

To configure the soft keys via Web interface:

1. Click webpage → Function keys → EXP KEY
2. Select the desired Expansion Key (Expansion1-Expansion6)
3. Select the desired key type from the Type field.
4. (Optional.) Enter the string that will appear on the phone screen in the label field.
5. (Optional.) Select the desired line from the Account ID field.
6. (Optional.) Enter the corresponding value in the Value field.
7. Click button to save the configuration.
8. (Optional) Click NextPage/PrePage button to turn the page.

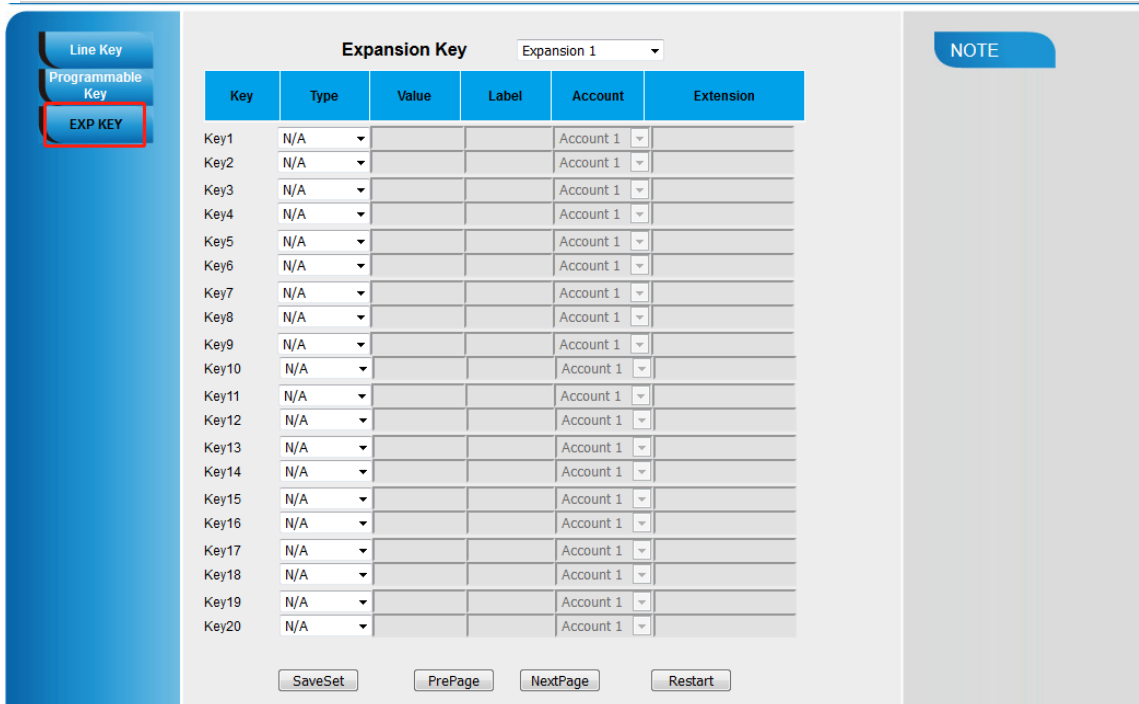

For detailed information about expansion modules, refer to [Expansion module](#).

Customizing Your Phone

Administrator Password

The password is mainly used for login the web interface or set the advanced settings through phone interface. And the default password of the administrator is: **admin**.

To change to password via phone interface

1. Press Menu→ Settings→ Advanced setting→ Password (default: admin) → Phone Setting → set Password
2. Enter the Current PWD (password), New PWD and confirm the new password.
3. Press Save soft key or  to save the new password.

To change to password via Web interface

1. Management→ Password

2. Fill in the value (Maximum length of Current Password/New Password/Confirm Password)

3. Click to save the configuration.

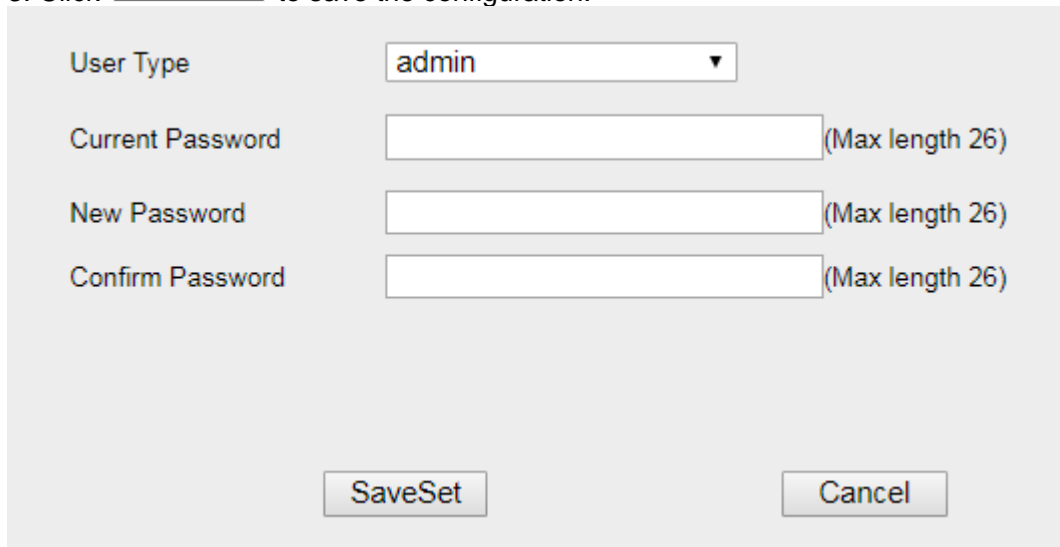

The screenshot shows a configuration form with the following fields and controls:

- User Type:** A dropdown menu with "admin" selected.
- Current Password:** A text input field with "(Max length 26)" to its right.
- New Password:** A text input field with "(Max length 26)" to its right.
- Confirm Password:** A text input field with "(Max length 26)" to its right.
- Buttons:** "SaveSet" and "Cancel" buttons are located at the bottom of the form.

Note:
When you use the web interface, default:
username: admin
password: admin

Language

The default Phone interface language is English.

To change the language via Phone interface

1. Press Menu→ Settings→ Basic Setting→ Language.
2. Select the necessary one.

3. Press  or Save soft key to save the configuration.

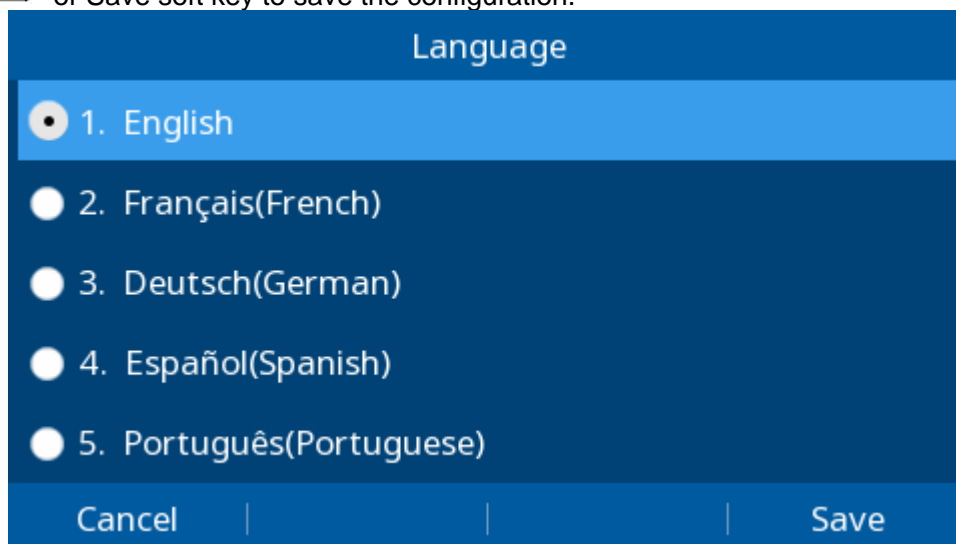

The screenshot shows a "Language" selection menu with the following options:

- 1. English (Selected)
- 2. Français(French)
- 3. Deutsch(German)
- 4. Español(Spanish)
- 5. Português(Portuguese)

At the bottom of the menu, there are "Cancel" and "Save" buttons.

To change the language via Web interface

1. Setting→ Preference→ Web Language & LCD Language
2. Select the necessary one.

3. Press to save the configuration.



Web Language	English	?
LCD Language	English	?

Note:
All languages may not be available for selection. The available languages depend on the language packs currently loaded to the IP phone.

Wallpaper

To change wallpaper, go by the following steps:

To change the wallpaper via Phone interface:

1. To press Menu→ Display→ Wallpaper
2. Press  and  or press Switch soft key to display the different pictures.
3. Press  or Save soft key to save the selected picture as the wallpaper.

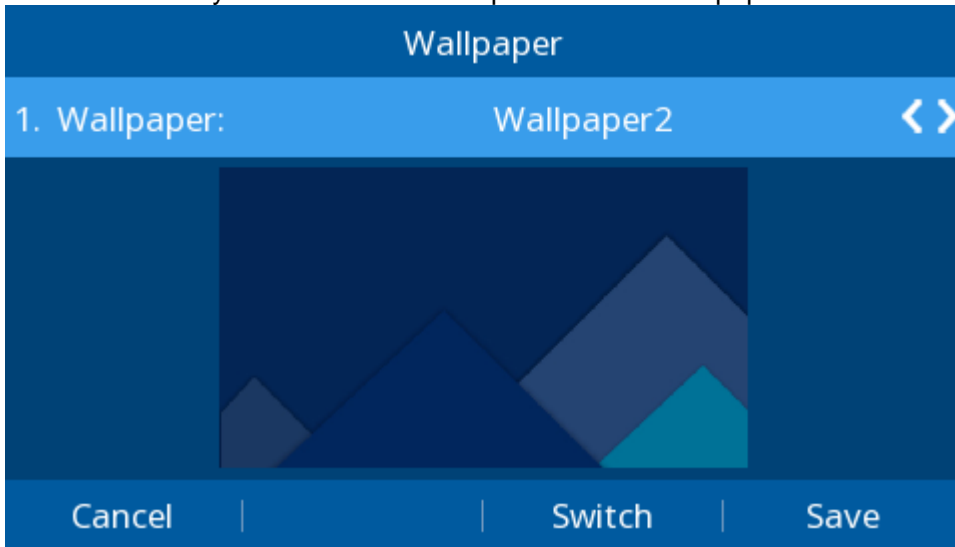

To change the wallpaper via Web interface:

1. Click Setting→ Preference
2. Select the desired wallpaper picture to upload.
3. Click to save the setting.

Wallpaper	Wallpaper2	?
Upload Wallpaper	<input type="button" value="Choose File"/> <input type="button" value="No file chosen"/>	?
	<input type="button" value="Upload Photo"/> <input type="button" value="Cancel"/>	
(Photo size should be less than 100KB, name length should be less than 48)		

To delete the wallpaper via Web interface:

1. Click Setting→ Preference
2. Select the desired wallpaper to delete.
3. Click to save the setting.

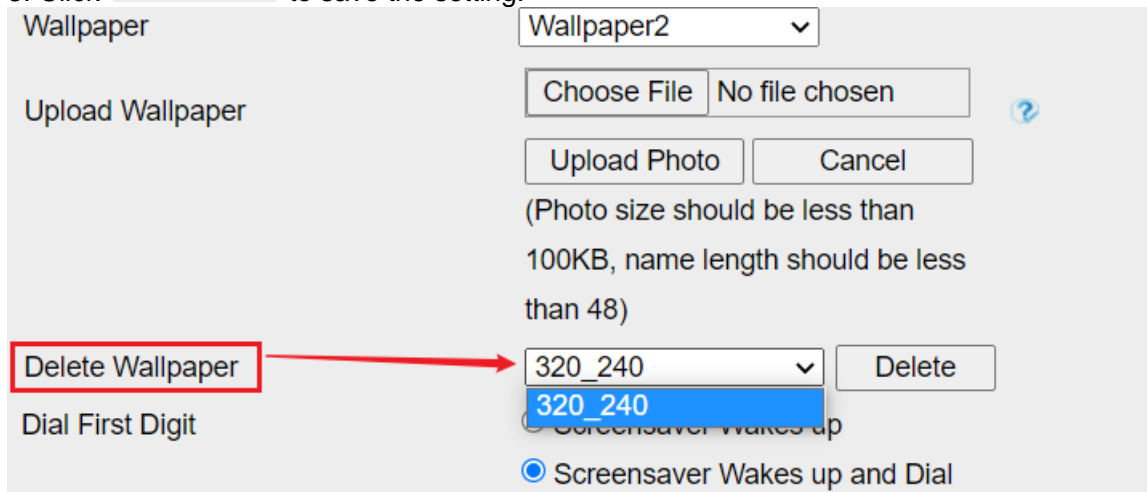

Note:

System wallpaper (Wallpaper1-Wallpaper3) cannot be deleted and only color Phone support upload wallpaper (Default: Wallpaper2).

Screen Saver

There are four types of screen saver: Time & Logo, Time Only, Photo Switch and Static Photo.

Time & Logo: when the screensaver works, it will show Time and logo in turns.

Time Only: when the screensaver works, it will only show Time

Photo Switch: all screensaver pictures display one by one.

Static Photo: Only the selected picture will display as screensaver.

Text Logo: It works with the **Time & Logo**, when enter the value, it will display the time and the entered value in turns.

To enable screen saver via Phone interface:

1. To press Menu→ Display→ Screensaver.

2. Press and or press Switch soft key or press and press and to choose the Screensaver as 1 minute or 2/5/10/30 minutes.

3. Press Save soft key to save the selected configuration.

4. Press Menu→ Display→ Screensaver → ScreenSaver Type and Enter soft key to enter Screensaver type, choose the Screensaver: Time & Logo, Time Only, Photo Switch and Photo.

5. Press Save soft key to save the selected configuration.

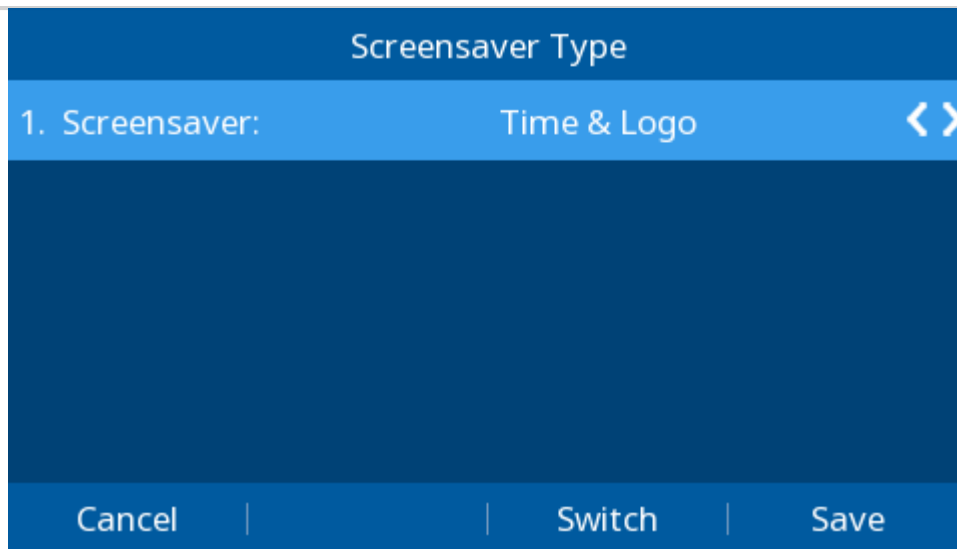

To disable screen saver via Phone interface

1. To press Menu→ Display→ Screensaver...

2. Press and or press Switch soft key or press and press and to choose the Screensaver as off.

3. Press or Save soft key to save the selected configuration.

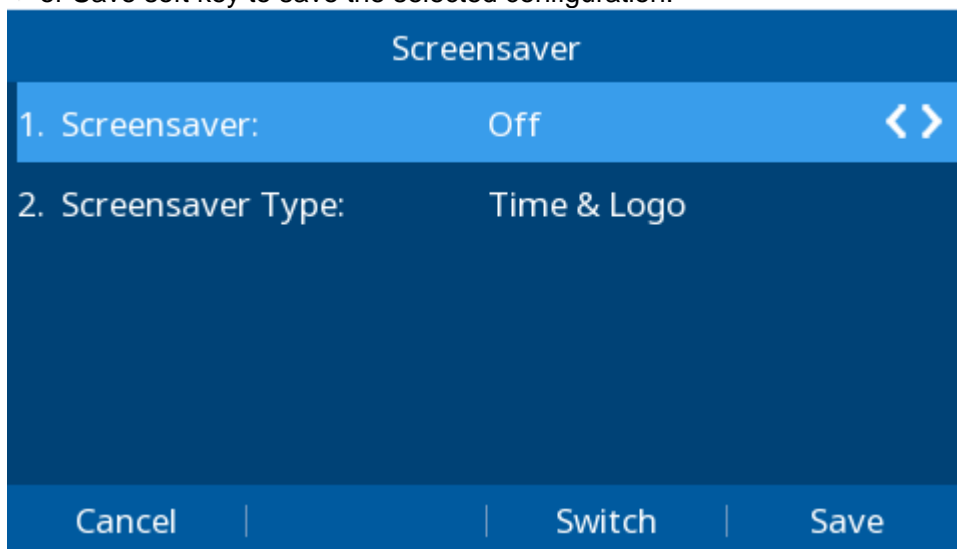

To upload screen saver via Web interface:

1. Setting→ Preference

2. Choose the picture wanted to use as screen saver

3. Click to save the upload picture

ScreenSaver Type

Upload Screen Photo No file chosen ?

(Photo size should be less than 100KB, name length should be less than 48)

ScreenSaver Photo

To delete upload screen saver photo via Web interface:

1. Setting→ Preference
2. Select the photo that to delete.
3. Click to delete the photo.

ScreenSaver Type

Upload Screen Photo No file chosen ?

(Photo size should be less than 100KB, name length should be less than 48)

ScreenSaver Photo

Note:

System Screen Photo (ScreenSaver1-ScreenSaver3) cannot be deleted and only color IP Phone support upload wallpaper.

To custom text logo via Web interface:

1. Click Setting→ Preference.
2. Choose the Screen Time Out as 1 min or 2/5/10/30 minute and choose the ScreenSaver Type as time & logo.
3. Enter the desired value in the Text Logo field.
4. Click to save the configuration.

Screen Time Out

Text Logo

ScreenSaver Type

it will work when screensaver type is time & logo or logo only, and ";" represents the newline

To wake up screen saver via Web interface:

1. Setting→ Preference
2. Choose Dial First Digit: Screensaver Wakes up or Screensaver Wakes up and Dial
3. Click to save the configuration.

Dial First Digit

Screensaver Wakes up

Screensaver Wakes up and Dial

Note:

1. The upload Photo size should be less than 100KB, name length should be less than 48 characters, and the File name should be letters, numbers, or underline '_' and photo number should be less than 9.
2. The default screensaver photos cannot be deleted.
3. You can only upload screen photos in format of '.bmp' and '.jpg'.

Backlight

To set Backlight via Web interface:

1. Click Setting→ Preference
2. Enter the time for Backlight time (In seconds).
The default is 0, which means Backlight is always on.
3. Click to save the configuration.







Note:

Backlight Time refers to the time into the backlight.

Time and Date



Time and date is displayed on the idle page, and it can be set automatically by SNTP server or manually by manual setting.

To configure the time and Date by SNTP setting via Phone interface

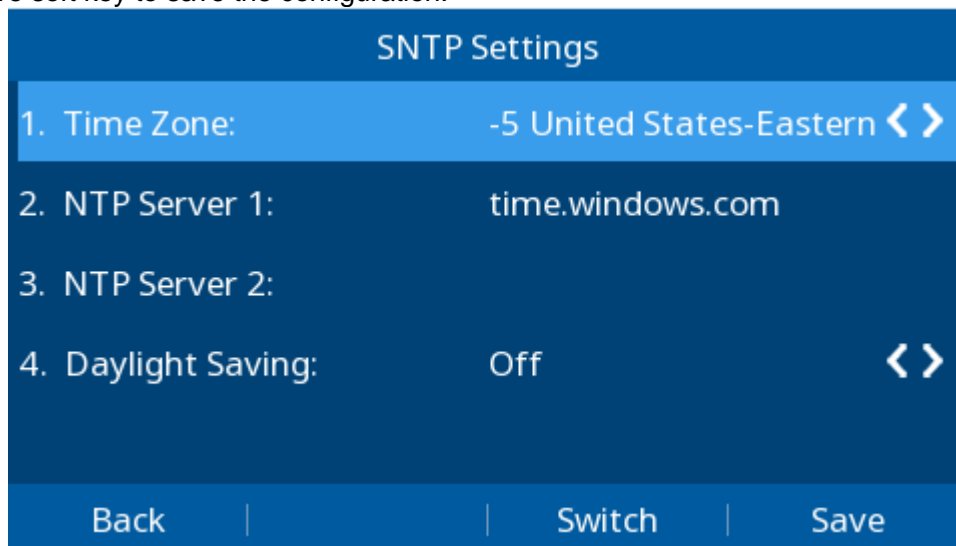
1. Press Menu→ Settings→ Basic Setting→ Time & Date→ SNTP Settings
2. Press  and  or Switch soft key or press  and press  and  to change the Time zone.
3. Fill in the NTP Server1, NTP Server2, and select the mode of Daylight Saving.
4. Press Save soft key to save the configuration.





To configure time and date manually via Phone interface

1. To press Menu→ Settings→ Basic Setting→ Time & Date→ Manual
2. Press  and  to change the right time, or you can input the right time.
3. Press Save soft key to save the configuration.

To configure the Time & Date Format via Phone interface

1. Press Menu→ Settings→ Basic Setting→ Time & Date Format

2. Press  and  or Switch soft key or press  and press  and  to change between 12 Hour or 24 Hour time display.

3. Press  and  or Switch soft key or press  and press  and  to change date display format.

4. Press Save soft key to save the configuration.

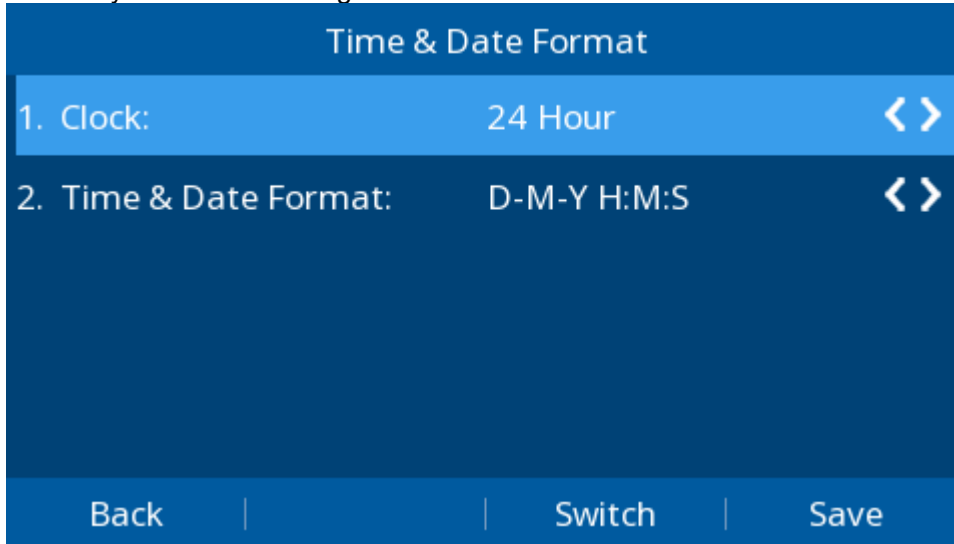

To configure the DHCP time via Phone interface

1. To press Menu→ Settings→ Basic Setting→ DHCP time

2. Press  and  or Switch soft key or press  and press  and  to change between Disable and Enable.

3. Press Save soft key to save the configuration.

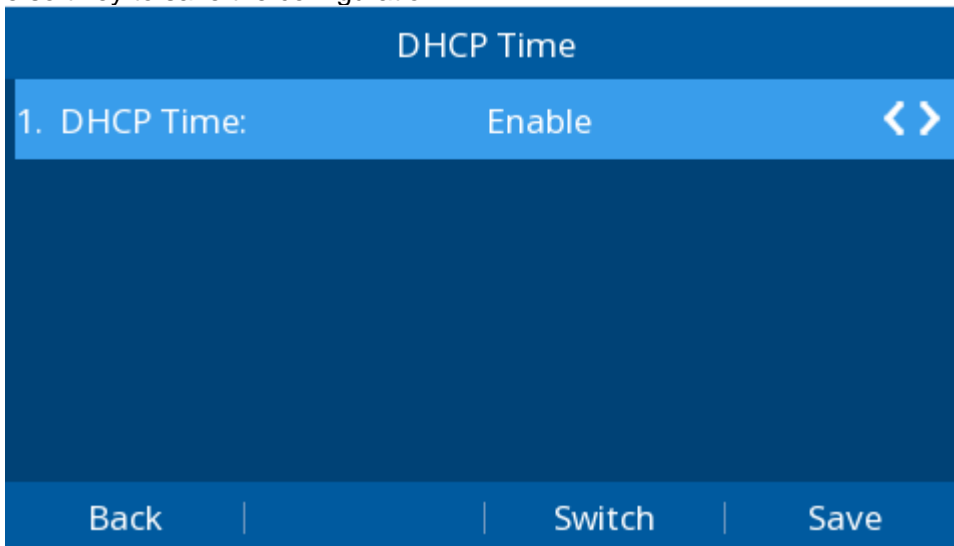

To configure the DHCP Option 100 via Web interface:

1. Log into the webpage (default username: admin, password: admin)

2. Setting→ Date & Time→ DHCP Option 100

3. Select Yes for the DHCP Option 100

4. Click  to save the configuration.

To configure the NTP Server via Web interface

1. Log into the webpage (default username: admin, password: admin)
2. Setting→ Date & Time→ NTP Server
3. Fill in the value in the blank.
4. Click to save the configuration.

NTP Server	<input type="text" value="time.windows.com"/>	?
Backup NTP Server	<input type="text"/>	?

To change the Time Zone and Date Display Format via Web interface

1. Setting→ Date & Time
2. Select the necessary one.
3. Click to save the configuration.

DHCP Option 100	<input type="radio"/> No <input checked="" type="radio"/> Yes	?
DHCP Time	<input checked="" type="radio"/> No <input type="radio"/> Yes	?
Time Zone	<input type="text" value="-5 United States-Eastern Time"/>	?
NTP Server is Covered with DHCP	<input checked="" type="radio"/> No <input type="radio"/> Yes	?
NTP Server	<input type="text" value="time.windows.com"/>	?
Backup NTP Server	<input type="text"/>	?
Update Interval (15~86400s)	<input type="text" value="120"/>	?
Current Time	NTP Server DNS Resolve Failure	?
SIP Date Override Time	<input checked="" type="radio"/> No <input type="radio"/> Yes	?
Account(SIP Date Override Time)	<input type="text" value="Account 1"/>	?
Daylight Saving Time	<input checked="" type="radio"/> Disable <input type="radio"/> Enable <input type="radio"/> Auto	?
Time Format	<input checked="" type="radio"/> 24 Hour <input type="radio"/> 12 Hour	?
Date Display Format	<input type="radio"/> Year - Month - Day <input type="radio"/> Month - Day - Year <input checked="" type="radio"/> Day - Month - Year	?

To change the SIP Date Override Time via Web interface

1. Setting→ Date & Time→ SIP Date Override Time
2. Select Yes or No for SIP Date Override Time.
3. Click to save the configuration.

SIP Date Override Time	<input checked="" type="radio"/> No <input type="radio"/> Yes	?
------------------------	---	---

To change the Account via Web interface

1. Setting→ Date & Time→ Account.
2. Select Yes for SIP Date Override Time and select desired Account.
3. Click to save the configuration.

DHCP Option 100	<input type="radio"/> No <input checked="" type="radio"/> Yes	?
DHCP Time	<input checked="" type="radio"/> No <input type="radio"/> Yes	?
Time Zone	-5 United States-Eastern Time	?
NTP Server is Covered with DHCP	<input checked="" type="radio"/> No <input type="radio"/> Yes	?
NTP Server	time.windows.com	?
Backup NTP Server		?
Update Interval (15~86400s)	120	?
Current Time	NTP Server DNS Resolve Failure	?
SIP Date Override Time	<input checked="" type="radio"/> No <input type="radio"/> Yes	?
Account(SIP Date Override Time)	Account 1	?

To change the Daylight Saving Time via Web interface

1. Setting→ Date &Time→ Daylight Saving Time
2. Select Disable or Enable or Auto for Daylight Saving Time.
3. Click to save the configuration.

Daylight Saving Time Disable Enable Auto [?](#)

Note:

If the IP Phone cannot obtain the time and date from the Simple Network Time Protocol (SNTP) server, please contact your system administrator for more information.

Daylight Saving Time

Daylight Saving Time (DST) is the practice of temporary advancing clocks during the summertime so that evenings have more daylight and mornings have less. Typically, clocks are adjusted forward one hour at the start of spring and backward in autumn. Many countries have used the DST at various times, details vary by location. The DST can be adjusted automatically from the time zone configuration. Typically, there is no need to change this setting.

LED Status Setting

The LED Status setting mainly defines the power indicator LED.

To configure LED Status via Web interface:

1. Click Setting→ Preference
2. Select Yes or No for Power Status, Ringing Status, Miss Calls Status and Voice Message Status.
3. Click for the setting.

For the LED status description, see LED Instruction [Power Indicator LED](#)

LED Status Setting:

Power Status	<input checked="" type="radio"/> Yes	<input type="radio"/> No
Ringing Status	<input checked="" type="radio"/> Yes	<input type="radio"/> No
MissCalls Status	<input type="radio"/> Yes	<input checked="" type="radio"/> No
Voice Message Status	<input type="radio"/> Yes	<input checked="" type="radio"/> No

Key as Send

To configure # as Send Key via Phone interface:

1. Press **Menu** → **Features** → **# as Send Key**
2. Switch the option to **Enable**.
3. Press **Save** soft key.

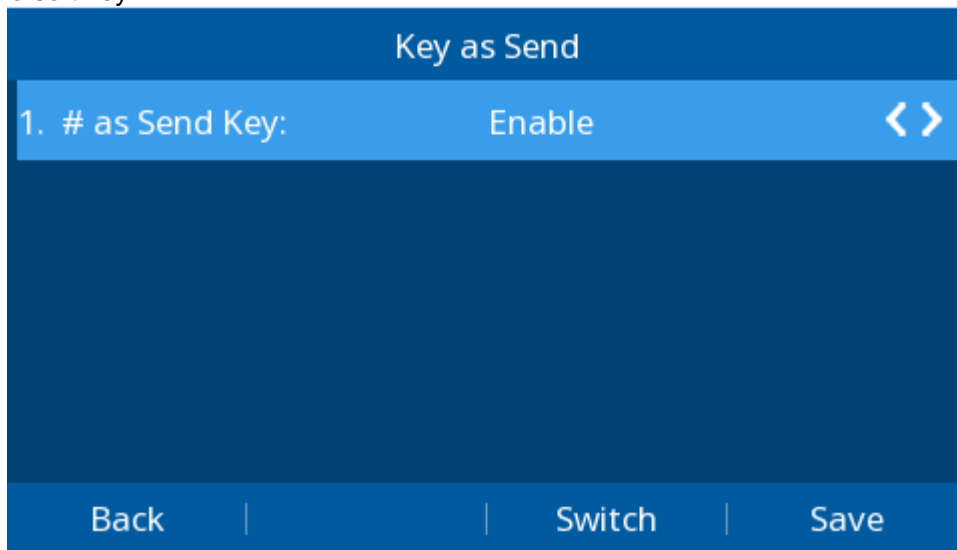

To cancel # as Send key via Phone interface:

1. Press **Menu** → **Features** → **# as Send key**
2. Switch the option to **Disable**.
3. Press **Save** soft key to save the configuration.

To configure # as Send key via Web interface:

1. Click **Setting** → **Preference**.
2. Select Yes or No for **Use # As Dial Key**.
3. Click **SaveSet** for the setting.

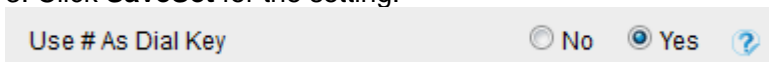

Dial Plan

Dial plan is a string of characters that governs the way this phone processes the inputs received from your phone keypad. This phone supports dial plan with following accepts digits:

1,2,3,4,5,6,7,8,9,0, *, #

Grammar	Description
x	any digit from 0-9;
xx+	at least 2-digit number;
^	exclude;
,	hear dial tone;
[3-5]	any digit of 3, 4, or 5;
[147]	any digit 1, 4, or 7;

<2=011>

replace digit 2 with 011 when dialing.

To configure dial plan via Web interface:

1. Click Account→ Basic.
2. Select the desired account from the pull-down list of Account in the Account field.
3. Fill in the value in Dial Plan field (Maximum length 1024).
4. Click to save the configuration.





Account	Account 1
Account Status	025@10.13.0.12:5060 : Registered; UDP
* Account Active	<input type="radio"/> No <input checked="" type="radio"/> Yes
Profile	Profile 1
Label	<input type="text"/> ?
* SIP User ID	025 ?
* Authenticate ID	025 ?
* Authenticate Password	●●●●●●●● ?
Name	<input type="text"/> ?
Local SIP Port	5060 ?
Use Random Port	<input checked="" type="radio"/> No <input type="radio"/> Yes
Voice Mail UserID	<input type="text"/> ?
Dial Plan	{[*]*+}
Eventlist BLF URL	<input type="text"/>
Shared Line	Disable
SCA Barge-In	Disable ?
Direct Call Pickup Code	<input type="text"/>
Group Call Pickup Code	<input type="text"/>
Feature Key Sync	Disable

Note:





1. Illegal input will fall back to default: {[*]*+}, illegal characters refer to all characters not within {}.
2. If the number you entered does not match the dial plan, you will not be able to make outgoing calls.

Phone Lock

To enable Keypad Lock via Phone interface:

1. Press Menu→ Settings→ Advanced Setting→ Phone Setting→ keypad Lock
2. Press ,  key or Switch soft key or press  and press  and  to change selected lock type: All keys, Menu Key, Function Key, Lock & Answer
3. Press Save soft key to save the configuration.

To disable Keypad Lock via Phone interface:

1. Press Menu→ Settings→ Advanced Setting→ Phone Setting→ keypad Lock
2. Press ,  key or Switch or press  and press  and  to change to choose Disable.
3. Press Save to save the configuration.

To enable Keypad Lock via Web interface:

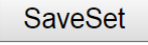
1. Click Setting→ Features→ Phone Lock
2. To choose All Keys, Menu Key, or Function Keys for the Keypad Lock.
3. Fill in the Phone Unlock Pin and Auto Lock Time-Out.
4. Fill in the Emergency number. When the phone is Lock, only Emergency number can be sent.
5. Click  to save the configuration.

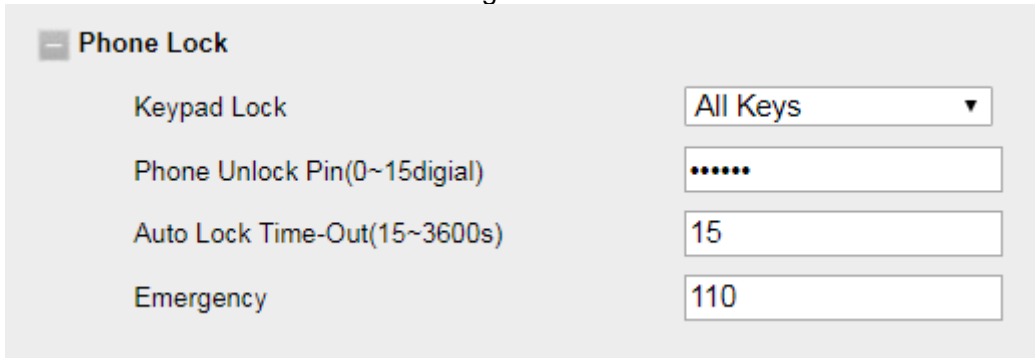
**To Disable Keypad Lock via Web interface:**

1. Click Setting→ Features→ Phone Lock
2. Choose Disable for the Keypad Lock.
3. Click  to save the configuration.

Emergency Call

Public telephone networks in countries around the world have a single emergency telephone number (emergency services number), that allows a caller to contact local emergency services for assistance when required. The emergency telephone number may differ from country to country. It is typically a three-digit number that can be easily remembered and dialed quickly. Some countries have a different emergency number for each of the different emergency services.

You can specify the emergency telephone numbers on the Desk Phone for contacting the emergency services in an emergency.

To configure emergency call via Web interface:

1. Click Setting→ Features→ Phone Lock
2. Enter the emergency services number in the Emergency field (maximum length 63).
3. Click  to save the configuration.

Phone Lock

Keypad Lock

Phone Unlock Pin(0~15digital)

Auto Lock Time-Out(15~3600s)

Emergency

Note: If multiple emergency calls are configured, they can be separated by commas. For example: 110,119,120.

Action URL

To configure action URL via Web interface:

1. Click Setting→ Action URL
2. Fill in the needed values in the designated blank spaces.
3. Click to save the configuration.

Setup Completed	<input type="text"/>	?
Log On	<input type="text"/>	?
Log Off	<input type="text"/>	?
Register Failed	<input type="text"/>	?
Off Hook	<input type="text"/>	?
On Hook	<input type="text"/>	?
Incoming Call	<input type="text"/>	?
Outgoing Call	<input type="text"/>	?
Call Established	<input type="text"/>	?
Call Terminated	<input type="text"/>	?
Open DND	<input type="text"/>	?
Close DND	<input type="text"/>	?
Open Always Forward	<input type="text"/>	?
Close Always Forward	<input type="text"/>	?

Open Busy Forward	<input type="text"/>	?
Close Busy Forward	<input type="text"/>	?
Open No Busy Forward	<input type="text"/>	?
Close No Busy Forward	<input type="text"/>	?
Transfer Call	<input type="text"/>	?
Blind Transfer call	<input type="text"/>	?
Attended Transfer Call	<input type="text"/>	?
Hold	<input type="text"/>	?
Unhold	<input type="text"/>	?
Mute	<input type="text"/>	?
Unmute	<input type="text"/>	?
Missed Call	<input type="text"/>	?
Idle To Busy	<input type="text"/>	?
Busy To Idle	<input type="text"/>	?
Forward Incoming Call	<input type="text"/>	?
Reject Incoming Call	<input type="text"/>	?
Answer New Incoming Call	<input type="text"/>	?
Transfer Finished	<input type="text"/>	?
Transfer Failed	<input type="text"/>	?

Softkey Layout

This feature mainly defines which shown on the soft key in some status. For example, what the soft key displays when dialing, or talking.

To configure Soft key via Web interface:

1. Click Setting→ Softkey Layout
2. Select Enable for Custom Softkey
3. Select Call States.
4. Select the feature from the Disable Keys to Enable Keys field by . moves the Disable key to Enable field. moves the Enable key, and it will back Disable field.
5. Click or to change to position for each feature.
6. Click to save the configuration.

Custom Softkey ?

Call States ?

Disable Keys Enable Keys

Unselected Softkeys Selected Softkeys(ordered
by position)**

<input type="text" value="Empty"/> <input type="text" value="History"/> <input type="text" value="Directory"/>	<input type="text" value="Send"/> <input type="text" value="IME"/> <input type="text" value="Delete"/> <input type="text" value="Cancel"/>
--	---

Note:

When there are more than 5 items in the Enable field, the last soft key will display More, and last two item will show on the next page of soft key, you can check by press More.

Settings

General Settings

Dial-Now Timeout

Dial-Now Timeout means that when you enter the number which is matching with dial plan, it will dial out automatically after some time when you stop entering the number.

To configure Dial-Now Timeout via Web interface:

1. Click Setting→ Preference
2. Fill the blank of Dial-Now Timeout: for example, 5(seconds).
0 means dial out immediately, default is 0 seconds, max is 29 seconds (between 0 to 29).
3. Click the button to save the configuration.

Dial-now Time-out (seconds) ?

No Key Entry Timeout

No Key Entry Timeout means that when you enter the number, it will dial out automatically after some time when you stop enter the number.

To configure No Key Entry Timeout via Web interface:

1. Click Setting→ Preference
2. Fill the blank of No Key Entry Timeout: for example, 5(seconds).
In seconds,0 means will not timeout, you should press the Dial key to dial out the number, default is 0 seconds, max is 29 seconds (between 0 to 29).
3. Click the button to save the configuration.

NO Key Entry Timeout(seconds)	<input type="text" value="5"/>	
-------------------------------	--------------------------------	---

Label Scroll

When setting function keys, you need to set the label of the function keys. If the words are too long to show on the label, you can use this function to make labels scroll. Another approach is to set the labels to Long Label mode.

To configure Label Scroll via Web interface:

1. Click Setting→ Preference
2. Select Enable or Disable for Label Scroll.
3. Click for the setting.

Lable Scroll	<input type="text" value="Enable"/>
--------------	-------------------------------------

Show Missed Calls

Whether to show missed call notification on LCD.

After turning off this function, all missed calls will not be displayed. If there are missed calls after turning it on again, the total number of missed calls during turning off and after turning on again will be displayed.

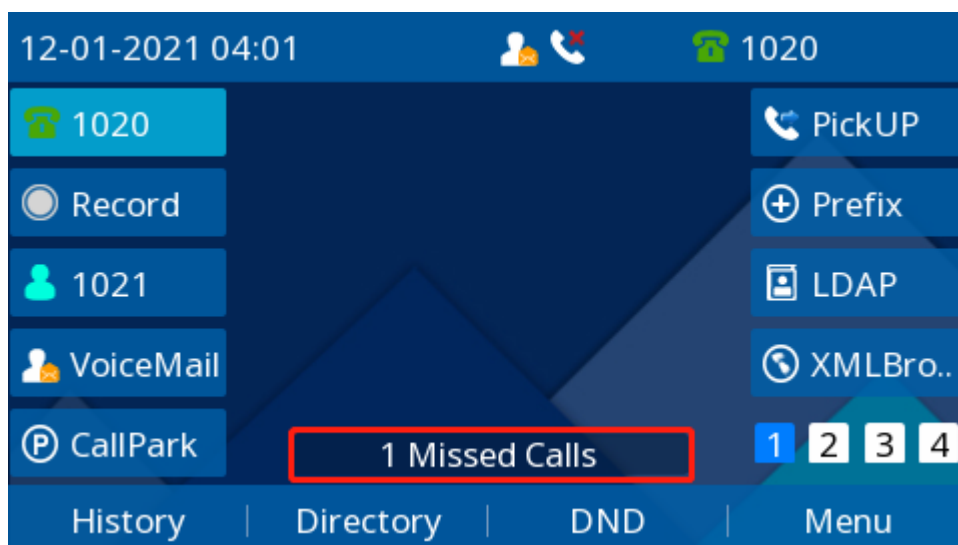

Note:

1. If it is turned on again, the missed call count during the closed period will not be displayed immediately but will be displayed together after the missed call count is increased again.
2. The data before closing Miss call will be cleared.

To configure Show Missed Calls via Web interface:

1. Click Setting→ Preference
2. Select Yes or No for Show Missed Calls.
3. Click for the setting.

Show Missed Calls Yes No

Auto Logout Time

Set the Web login timeout.

1. Login webpage, and click Setting→ Preference
2. Set number 1~5000 min for Auto Logout Time.
3. Click for the setting.

Auto Logout Time (1 ~ 5000 min)

Reboot in Talking

This function is to allow reboot during the calls or not. When this function is disabled, reboot will not be executed immediately during the call, but will be executed after the call ends. When this function is enabled, reboot will be executed immediately during the call.

1. Login webpage, and click Setting→ Preference
2. Set Enable or Disable for Reboot in Talking.
3. Click for the setting.

Reboot in Talking

Detect IP Conflict

The IP phone will detect whether there is an IP conflict after obtaining the IP address. If so, it will prompt the IP conflict in the LCD pop-up box; you can select "Cancel" to ignore it or "Reboot" to let the phone re-request an IP address.

1. Login webpage, and click Setting→ Preference
2. Set Enable or Disable for Detect IP Conflict.
3. Click for the setting.

Detect IP Conflict

Redial Mode

Call redial has two ways:

- (1) To redial the last placed call from the IP Phone.
- (2) To redial the call from all calls list.

1. Login webpage, and click Setting→ Preference
2. Set Direct Mode or Select Mode for Redial Mode.
3. Click for the setting.

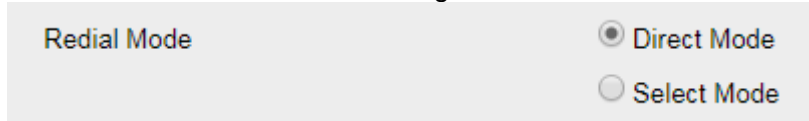

Redial Mode Direct Mode
 Select Mode

Suppress DTMF Display

Whether to hide DTMF during the call; if this function is enabled, the DTMF during the call will be displayed as *.

1. Login webpage, and click Setting→ Preference
2. Select On or Off for Suppress DTMF Display.
3. Click for the setting.



Suppress DTMF Display Off On

Suppress DTMF Display Delay

Whether to display briefly before hiding DTMF. The premise is suppressing DTMF Display On.

1. Login webpage, and click Setting→ Preference
2. Select On or Off for Suppress DTMF Display Delay.
3. Click for the setting.

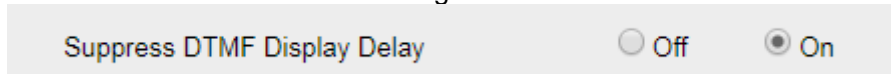

Suppress DTMF Display Delay Off On

Check-Syn With Authenticate

If this option is enabled, the server needs to be authenticated before the phone agrees to synchronize.

1. Login webpage, and click Setting→ Preference
2. Set Enable or Disable for Check-Syn With Authenticate.
3. Click for the setting.

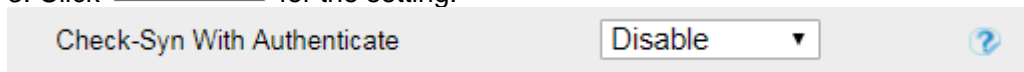

Check-Syn With Authenticate

Headset Mode

23. How to configure Headset Priority via Phone interface:

1. Find Menu then navigate as follows: Menu->Settings->Basic Setting->Headset:
2. Enable the Headset Priority.

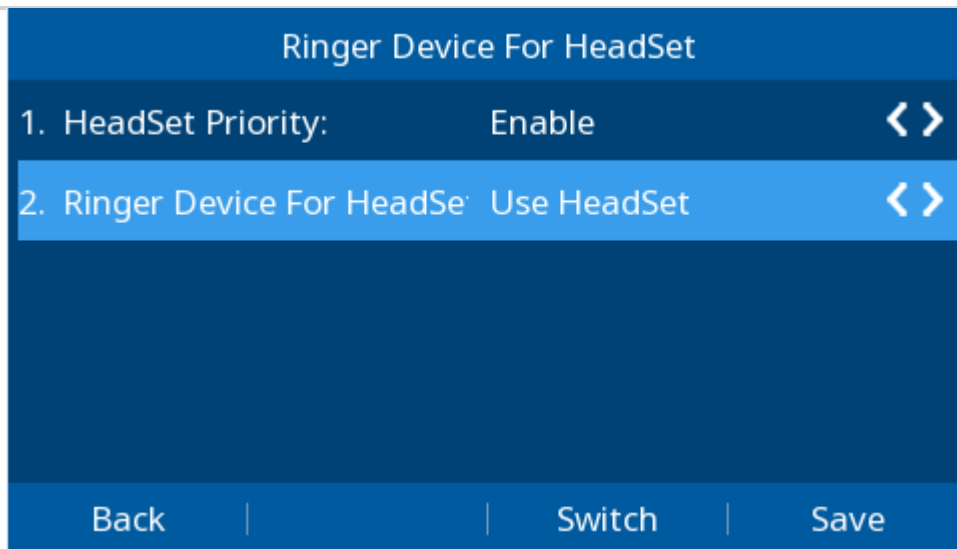

3. Choose the “Use Headset” or “Speaker&Headset” from “Ringer Device For Headset” option.
4. Press the save soft key to save the configuration.

24. To configure Headset Priority via web interface:

1. Login the phone’s webpage (Username: admin, Password: admin)
2. Setting->Preference. Enable the Headset priority. Choose the “Use HeadSet” or “Speaker&Headset” from “Ringer Device For Headset” option.

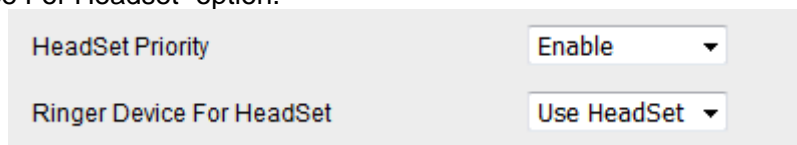

3. Click the  button to save the configuration.

25. To enable the headset mode:

Enable headset mode when headset priority is enabled:

1. Press the headset key on phone’s during the idle status when you accomplish the above-mentioned configuration.
2. Headset icon will display on phone status bar

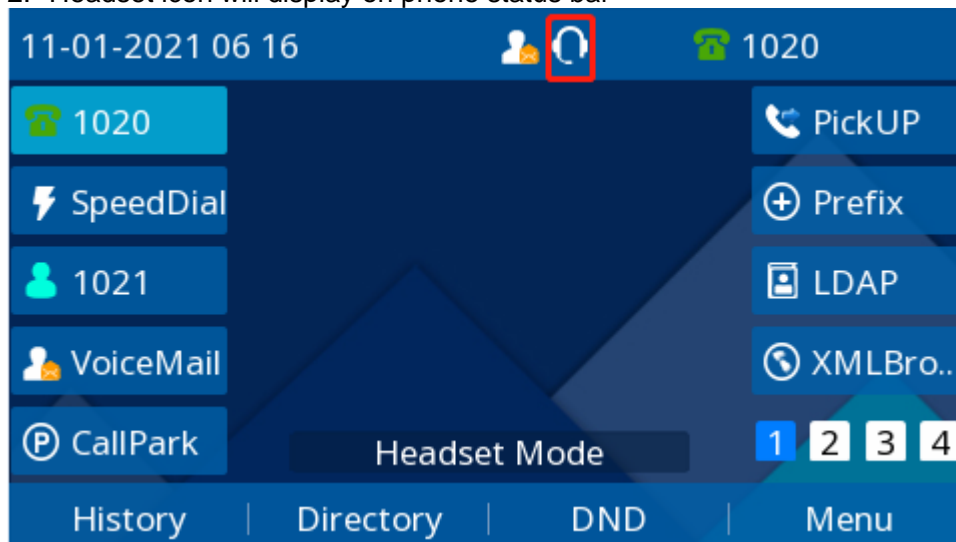

Enable headset mode when headset priority is not enabled:

- Press the headset key on phone

After pressing the headset key, the phone enters the dialing mode. And the headset is used only for calling.

When dialing or calling, the headset is used as an answer mode, and the headset is not used by default as in the preceding case.

Network setting

IP Phone supports IPv4, IPv6, IPv4&IPv6. They have two mode of Network: DHCP and Static. The default mode is DHCP, it will obtain IP address and other information automatically.

If your phone cannot contact a DHCP server for any reason, you need to configure a static IP address manually.

When switch DHCP and Static IP Address, or change the Static IP on webpage, it will show the warning of restart as following.

Network settings have been changed, Are you sure reboot the phone to save changes?

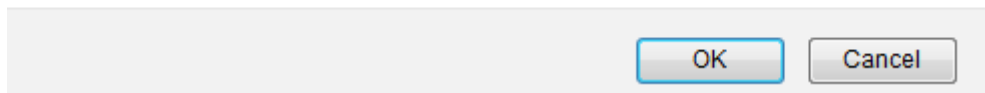



IPv4

If you set IP Mode to IPv4, IP phone will use IPv4 address. IPv4 has two network modes: DHCP and Static.

To configure IPv4 via Phone interface:

1. Press Menu→ Settings→ Advanced Setting (password: admin) → Network→ WAN Port→ IP Port Mode.

2. Press  and  or Switch soft key to change the IP Port Mode.

3. Press  or Save soft key to save the configuration.

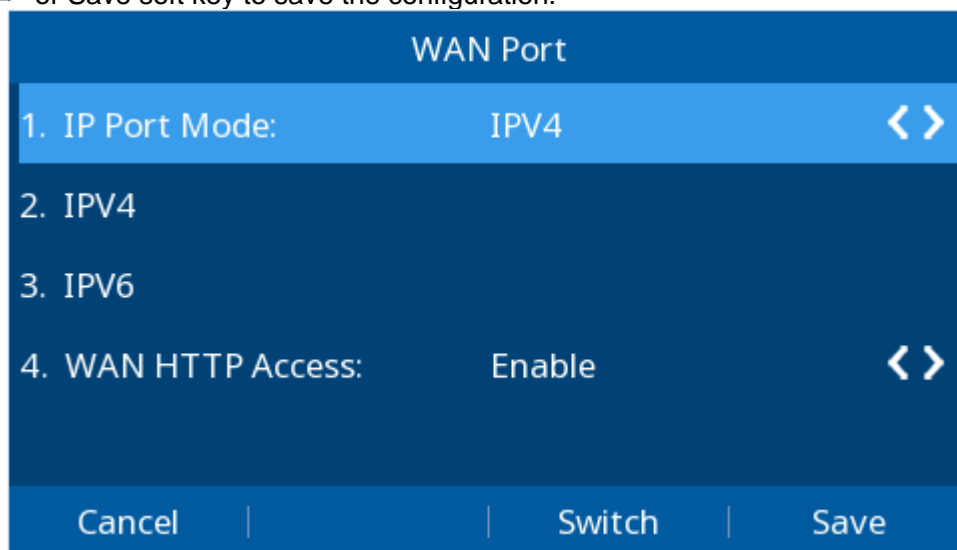

To configure IPv4 via Web interface:

1. Click Network→ Basic→ Internet Port

2. Select IPv4 for Internet Port.

3. Click  for the setting.

● Internet Port

IP Mode (IPv4/IPv6)

IPv4

To configure DHCP via Phone interface:

1. Press Menu→ Settings→ Advanced Setting (password: admin) → Network→ WAN Port→ IPv4→ DHCP mode.
2. Click Save and the pop-up box shows "System will reboot, Are you sure?".

To configure a static IP address via Phone interface:

1. Press Menu→ Settings→ Advanced Setting (password: admin) → Network→ WAN Port→ IPv4→ Static mode.
2. Enter the parameters: IP, Netmask, Gateway, Pri.DNS (primary DNS), Sec.DNS (second DNS) in the corresponding fields.

IPV4			
1. WAN Type:	Static mode <>		
2. IP:	10.20.0.43		
3. Netmask:	255.255.255.0		
4. Gateway:	8.8.8.8		
5. Pri.DNS:	114.114.114.114		
Back	2ab	Delete	Save

1. Click Save and the pop-up box shows "System will reboot, Are you sure?".
2. Press the OK soft key to accept the change or the Cancel soft key to cancel.

To configure Network via Web interface:

1. Click Network→ Basic→ IPv4 Setting
2. Select the desired Type: DHCP or Static IP Address.
3. Fill in the necessary information.
4. Click and the pop-up box shows "System will reboot, Are you sure?".

● **IPv4 Setting**

DHCP ?

DHCP HostName

DHCP Domain

DHCP Vendor Class Id

DHCP User Class

Static IP Address ?

IP Address . . .

Subnet Mask . . .

Default Gateway . . .

Static DNS No Yes

Primary DNS . . .



Secondary DNS . . .

IPv6

If you set IP Mode to IPv6, IP phone will use IPv6 address. IPv6 has two network modes: DHCP, Static IP Address.

To configure IPv6 via Phone interface:

1. Press Menu → Settings → Advanced Setting (password: admin) → Network → WAN Port → IP Port Mode.

2. Press  and  to change the IP Port Mode.

3. Press  or Save soft key to save the configuration.

WAN Port

1. IP Port Mode:	IPV6	< >
2. IPV4		
3. IPV6		
4. WAN HTTP Access:	Enable	< >

Cancel
Switch
Save

To configure IPv6 via Web interface:

1. Click Network → Basic → Internet Port
2. Select IPv6 for Internet Port.

3. Click **SaveSet** for the setting.

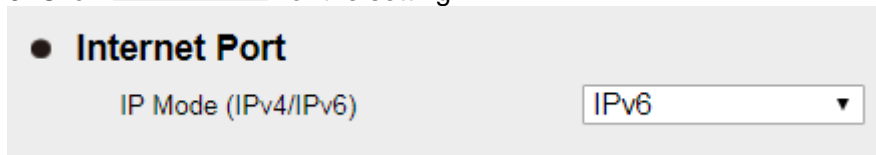

To configure DHCP via Phone interface:

1. Press Menu→ Settings→ Advanced Setting (password: admin)→ Network→ WAN Port→ IPv6→ DHCP mode.
2. Click Save and the pop-up box shows "System will reboot, Are you sure?".

To configure a static IP address via Phone interface:

1. Press Menu→ Settings→ Advanced Setting (password: admin) → Network→ WAN Port→ IPv6→ Static mode.
2. Enter the parameters: IP, IPV6 Prefix, Gateway, Pri.DNS (primary DNS), sec.DNS (second DNS) in the corresponding fields.

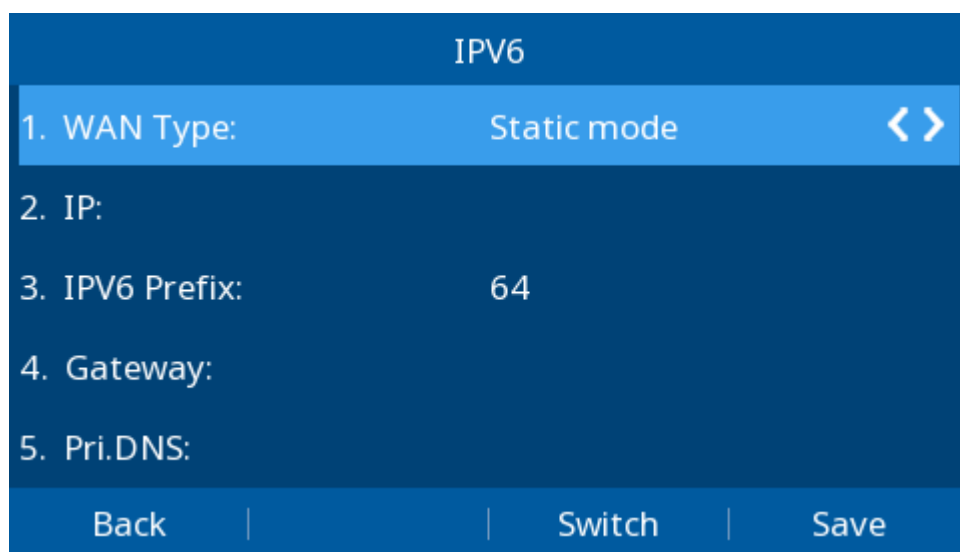

3. Click Save and the pop-up box shows "System will reboot, Are you sure?".

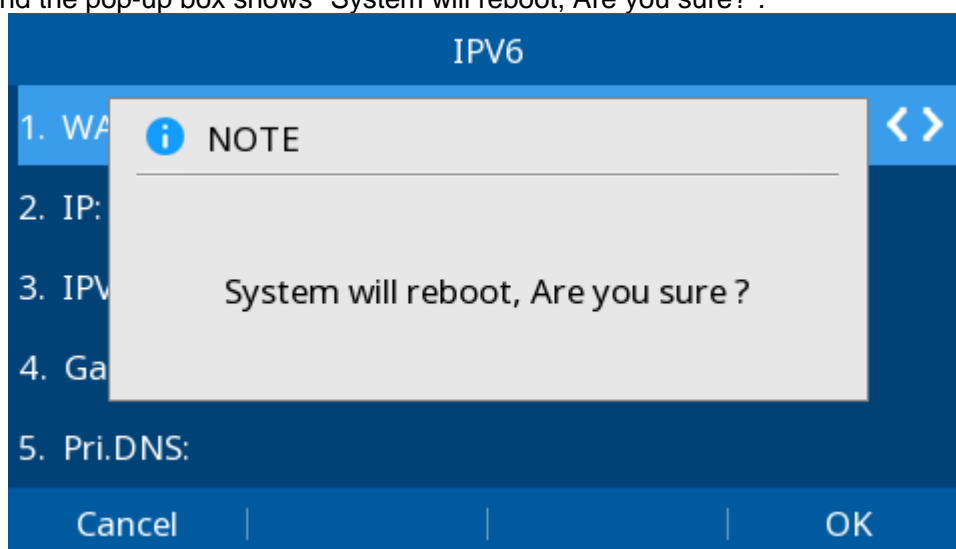

To configure Network via Web interface:

1. Click Network→ Basic→ IPv6 Setting
2. Select the desired Type: DHCP, Static IP Address.

3. Fill in the required fields.

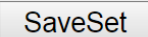
4. Click  and the pop-up box shows "System will reboot, Are you sure?".

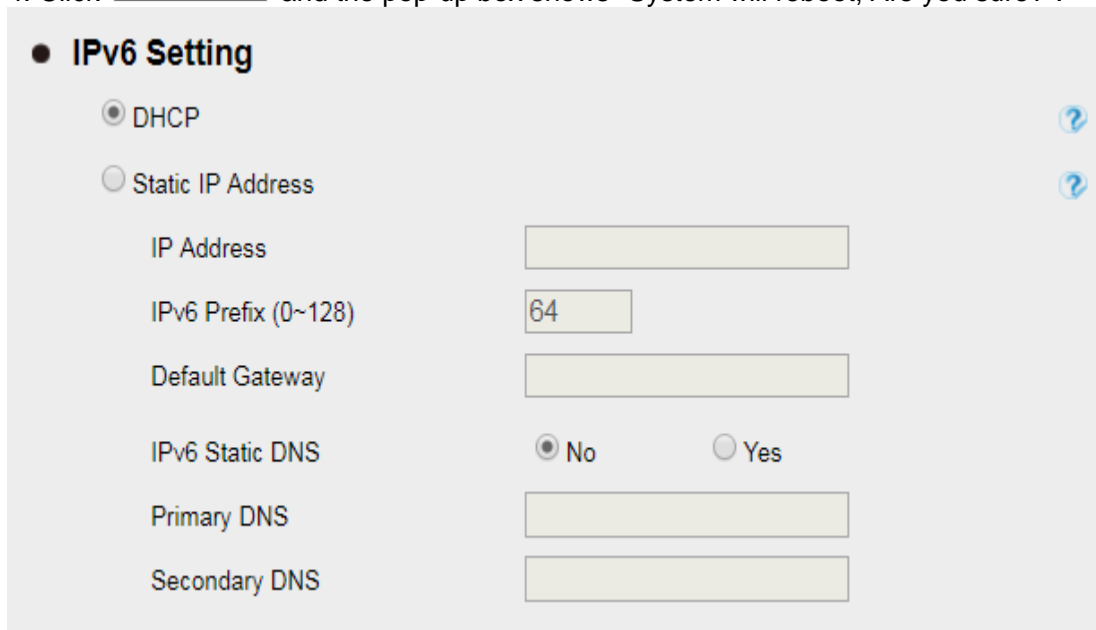



The screenshot shows the 'IPv6 Setting' configuration screen. It has two radio button options: 'DHCP' (selected) and 'Static IP Address'. Below these are several input fields: 'IP Address', 'IPv6 Prefix (0~128)' (with '64' entered), 'Default Gateway', 'IPv6 Static DNS' (with 'No' selected), 'Primary DNS', and 'Secondary DNS'. Each field has a corresponding input box or radio button.

IPv4&IPv6

If you set IP Mode to IPv4&IPv6, IP phone will support both IPv4 and IPv6 address. The settings of DHCP and Static IP Address are same as above.

To configure IPv4&IPv6 via Phone interface:

1. Press Menu → Settings → Advanced Setting (password: admin) → Network → WAN Port → IP Port Mode.

2. Press  and  to change the IP Port Mode.

3. Press  or Save soft key to save the configuration.

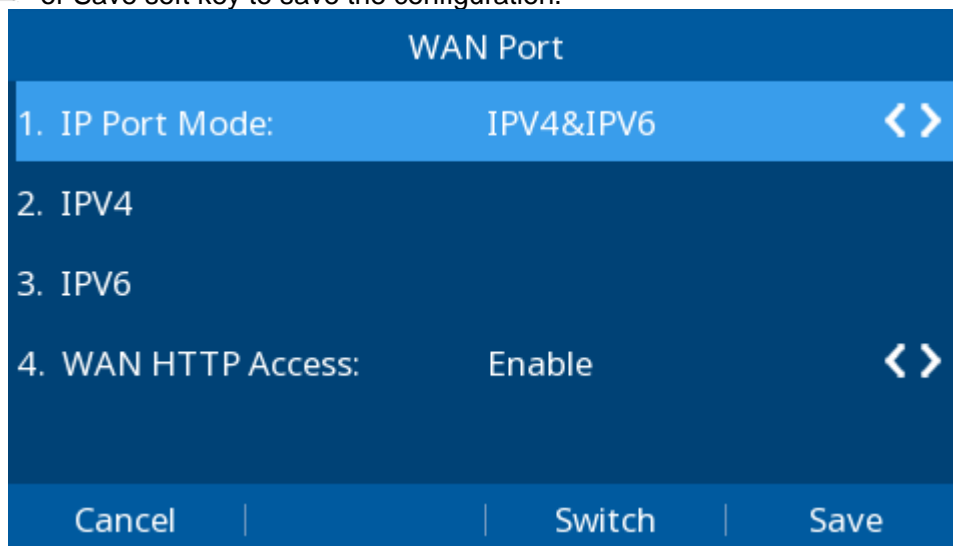

The screenshot shows the 'WAN Port' configuration screen. It has a title bar 'WAN Port'. Below it are four items: '1. IP Port Mode: IPV4&IPV6', '2. IPV4', '3. IPV6', and '4. WAN HTTP Access: Enable'. Each item has a double arrow icon to its right. At the bottom, there are three buttons: 'Cancel', 'Switch', and 'Save'.

To configure IPv4&IPv6 via Web interface:

1. Click Network → Basic → Internet Port

2. Select IPv4&IPv6 for Internet Port.

3. Click  for the setting.

● **Internet Port**

IP Mode (IPv4/IPv6)

Preference(IPv4/IPv6)

Note:

Wrong network parameters may result in inaccessibility of your phone and may also have an impact on your network performance. For more information about these parameters, contact your system administrator.

Preference (IPv4/IPv6)

When the network set as IPv4&IPv6 dual stack mode, you can set the parameter “Preference (IPv4/IPv6)” to choose which IP protocol will be used in the higher priority.

Note: This function will only be displayed in IPv4&IPv6 dual stack, that is, when IP Mode (IPv4/IPv6): IPv4&IPv6, the Preference function will be displayed.

To configure Preference via Web interface:

1. Click Network→ Basic→ Internet Port → Preference (IPv4/IPv6)
2. Select IPv4 or IPv6 as you prefer.
3. Click for the setting.

● **Internet Port**

IP Mode (IPv4/IPv6)

Preference(IPv4/IPv6)

4. If change the Preference on webpage, a warning window will pop up, "Network settings have been changed, are you sure reboot the phone to save changes?" Click OK, the phone will restart.

Network settings have been changed, Are you sure reboot the phone to save changes?

PC Port

Two modes for PC Port: bridge and Connect to Expansion Module.

To Select the PC Port via Phone interface:

1. Press Menu→ Settings→ Advanced Setting (password: admin) → Network→ PC Port→ Bridge mode/Expansion Module.
2. Click Save and the pop-up box shows "System will reboot, Are you sure?".
3. Click the OK button, then the phone will reboot.

To Select the PC Port via Web interface:

1. Click Network→ PC Port
2. Select As Bridge/Connect to Expansion Module.

3. Click and then click , the phone will reboot automatically.

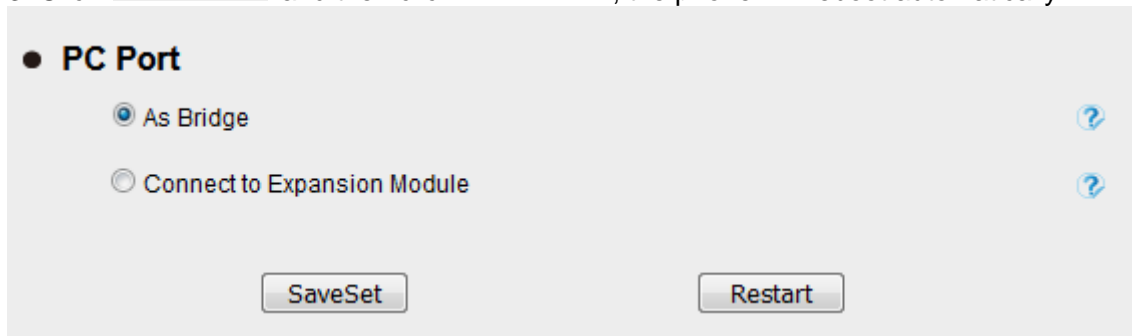

Note: The As Bridge mode is selected by default, and the “Connect to Expansion Module” mode is only required when the phone is connected to the expansion module.

System setting

Factory Reset

To set Factory Reset via Phone interface

1. Press Menu→ Settings→ Advanced Setting (default password: **admin**)→ Phone Setting→ Factory Reset
2. Press OK soft key in the warning page.

To set Factory Reset via Web interface

1. Click Management→ Upgrade
2. Click and then confirm the setting.

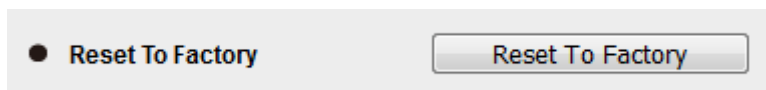

Pcap Feature

To use Pcap feature via Web interface:

1. Click Management→ Tools
2. Click and then operation the phone
3. When finishing the operation, click and then click .
4. Then you'll get the Pcap captures.

● Pcap Feature:

● Lcd Screen

● Port Mirror Disable Enable

● Rpcapd Disable Enable

● Diagnostic Mode

System Log

To download system log via Web interface:

1. Click Management→ Configuration
2. Select the Syslog Level

● **System Log**

Download System Log

Syslog Server

Syslog Level

3. Click of the System Log.
4. Then you will get a txt file: syslog.txt.

 syslog.txt

Upgrade

To upgrade via HTTP, the “Management” → “Auto Provision” → “Firmware Upgrade” → “Upgrade Mode” field needs to be set to HTTP, respectively. “Firmware Server Path” needs to be set to a valid URL of a HTTP server, server name can be in either FQDN or IP address format. Here are examples of some valid URL.

e.g. firmware.mycompany.com:5688/

e.g. www.mycompany.com:5688/fm

e.g. 218.2.83.110

Instructions for firmware upgrade via HTTP:

- (1) End users can choose to download the free HTTP server from <http://httpd.apache.org/> or use Microsoft IIS web server. Then setup HTTP server.
- (2) Unzip the firmware file and put all of them under the *root/fm* directory of the HTTP server.

To configure the server path via Web interface:

1. Click Management→ Auto Provision
2. Select the upgrade mode in the Upgrade Mode field

3. Enter the Firmware Server Path and Config Server Path (192.168.0.254 is HTTP server).
4. Enter the HTTP server's username and password (optional).
5. Click the **SaveSet** button to save the configuration.
6. Restart the UC507U, IP Phone will restart and auto-get firmware files from HTTP server.

Firmware Upgrade

PNP Active No Yes

Upgrade Mode TFTP HTTP FTP HTTPS

Firmware Server Path

Config Server Path

Allow DHCP Option

Server Pnp Port

Allow DHCP Option Server No Yes

AUTO Upgrade: No Yes

Power-on start No Yes

Repetition period No Yes

Update time : -- :

Upgrade EXP Firmware No Yes

HTTP/FTP/HTTPS UserName

HTTP/FTP/HTTPS Password

Pre/Postfix Control

Firmware/Config File Prefix

Firmware/Config File Postfix

Upgrade Check Mode :

NOTES:

- We recommend end-user use HTTP server. For large companies, we recommend maintaining their own TFTP/HTTP/FTP/HTTPS server for upgrade and provisioning procedures.
- Once a "Firmware Server Path" is set, user needs to update the settings and restart the IP Phone. If the configured firmware server is found and a new code image is available, the UC507U will attempt to retrieve the new image files by downloading them into the UC507U's SDRAM. During this stage, the UC507U's LEDs will blink fast until the checking/downloading process is completed. Upon verification of checksum, the new code image will then be saved into the Flash. If TFTP/HTTP/FTP/HTTPS fails for any reason (e.g. TFTP/HTTP/FTP/HTTPS server is not responding, there are no code image files available for upgrade, or checksum test fails, etc), the UC507U will stop the TFTP/HTTP/FTP/HTTPS process and simply boot using the existing code image in the flash.
- Firmware upgrade may take as long as 3 to 8 minutes over Internet, or just 1 minutes if it is performed on a LAN. It is recommended to conduct firmware upgrade in a controlled LAN environment if possible. For users who do not have a local firmware upgrade server.
- Please contact with your provider for the latest firmware.
- Oversea users are strongly recommended to download the binary files and upgrade firmware locally in a controlled LAN environment.

To upgrade manually via the Web configuration interface

1. Click Management → Upgrade
2. Click **Choose File** or the blank.

3. Select the firmware and then click

Upgrade

Configuration File

To download configuration file

1. Click Management→ Configuration→ Configure File

2. Click the or , then you can get a file: cfg.xml or cfg.bin.

The screenshot shows a web interface titled "Configure File". It contains several rows of configuration options, each with a text label and a corresponding button. The first two rows are highlighted with a red border:

Download Device Xml Configuration	<input type="button" value="Download Xml File"/>
Restore Xml Configuration	<input type="button" value="Choose File"/> No file chosen <input type="button" value="Restore Xml Configuration"/>
Download Device Bin Configuration	<input type="button" value="Download Bin File"/>
Restore Bin Configuration	<input type="button" value="Choose File"/> No file chosen <input type="button" value="Restore Bin Configuration"/>
Download User Bin Configuration	<input type="button" value="Download User Bin File"/>
Delete User Configuration	<input type="button" value="Delete User File"/>

To restore a configuration file

1. Click Management→ Configuration→ Configure File

2. Select the xxx.xml or xxx.bin file, and then Click the or , then IP Phone will reboot.

● **Configure File**

Download Device Xml Configuration	<input type="button" value="Download Xml File"/>
Restore Xml Configuration	<input type="button" value="Choose File"/> No file chosen
	<input type="button" value="Restore Xml Configuration"/>
Download Device Bin Configuration	<input type="button" value="Download Bin File"/>
Restore Bin Configuration	<input type="button" value="Choose File"/> No file chosen
	<input type="button" value="Restore Bin Configuration"/>
Download User Bin Configuration	<input type="button" value="Download User Bin File"/>
Delete User Configuration	<input type="button" value="Delete User File"/>

Optional Accessories with Your Phone

Headsets

The phone supports wired headset and Bluetooth headset to place and answer calls. You can use only one headset at a time.

Note: Bluetooth headset is only supported by UC507U.

Bluetooth Headset

You can use a Bluetooth headset to handle calls on the phones. For more information, refer to the documentation from your Bluetooth headset manufacturer.

Using Headsets

After connecting a headset to your phone, you can activate the headset mode and use the headset when answering and placing calls. If you do not want to use a headset to handle calls, you can deactivate the headset mode.

To use the headsets:

1. Press the HEADSET key  on the phone.
2. The headset icon appears on the phone screen.

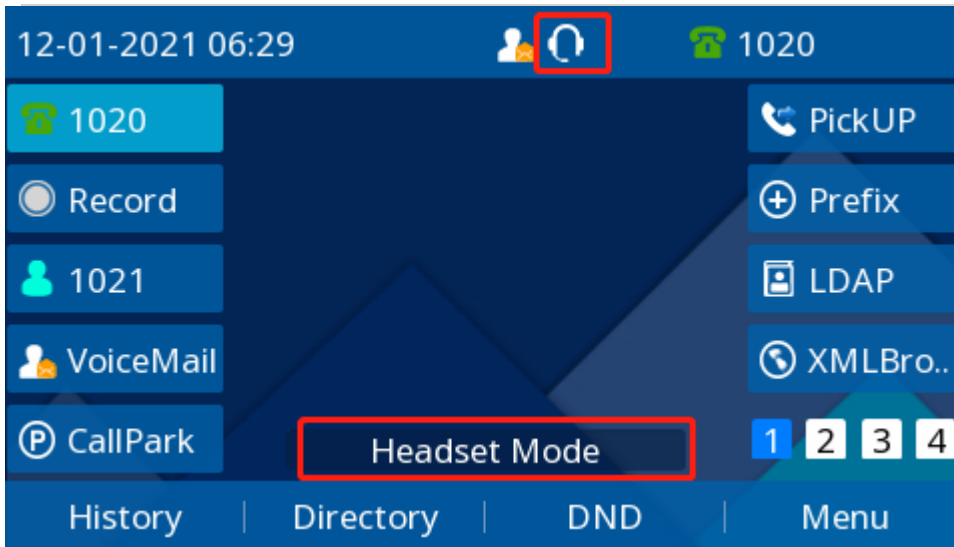

3. Press the HEADSET key  again on the phone. The headset icon disappears from the phone screen.

Expansion module

The expansion module is a console you can use to connect to a phone to add additional Ext keys and expand the functions of your phone.

For more information about the expansion module, please contact technical support, refer to the expansion module user guide.

Note: Expansion module is only supported by UC507U.

26. How to connect expansion modules?

1. You can connect the expansion module to your phone, using the supplied materials in the expansion module's packaging.
2. Click to Network->PC port.
3. Select to the Connect to Expansion Module.



4. Click the  button to save the configuration.

5. Click the  button to restart the IP Phone.

6. The phone will restart. After restarting, you can see that the phone is connected to the expansion module, as shown in the figure below, showing the relevant version information.

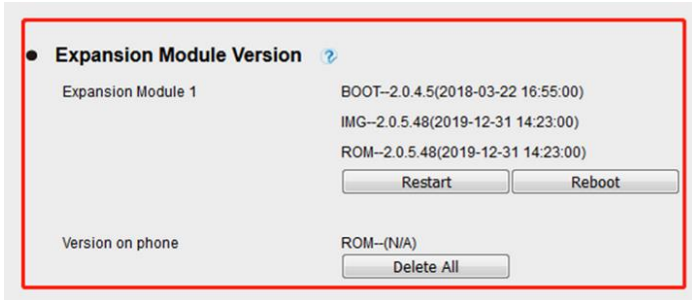

Troubleshooting

Why is the phone LCD screen blank?

- Ensure your phone is properly plugged into a functional AC outlet.
- Ensure that the phone is not plugged into a plug controlled by a switch that is off.
- If the phone is plugged into a power strip, try plugging it directly into a wall outlet instead.
- If your phone is powered from PoE, ensure you use a PoE compliant switch or hub, or contact your system administrator for more information.
- Check if the power LED is on to ensure that the phone is powered on.

Why does the phone display “Network Unavailable”?

To resolve:

- Ensure that the Ethernet cable is plugged into the Internet port on the phone and the Ethernet cable is not loose.
- Ensure that the switch or hub in your network is functioning well.
- If the problem persists, Contact your system administrator for more information.

Why can't I get a dial tone?

To resolve:

- Check for any loose connections and that the phone has been installed properly. For the Installation instructions, refer to the [Phone Installation](#) section.
- Check whether dial tone is present on one of the audio modes.
- Switch between the Handset, Headset (if you have) or Hands-Free Speakerphone to check whether dial tone is present for one of the audio modes.
- If the dial tone exists on another audio mode, connect a different handset or headset to isolate the problem.

Where to set the tone?

You can set the tone on web interface:

- Click Setting→ Tones
- Define the Dial Tone, Ringback Tone, Busy Tone...
- For the tones, you can check with your system administrator.

Select Country	Custom
Dial Tone	f1=350@-13,f2=440@-13,c=0/0;
Ringback Tone	f1=440@-19,f2=480@-19,c=2000/4000;
Busy Tone	f1=480@-24,f2=620@-24,c=500/500;
Reorder Tone	f1=480@-24,f2=620@-24,c=250/250;
Confirmation Tone	f1=350@-11,f2=440@-11,c=100/100-100/100-100/100;
Call Waiting Tone	f1=440@-13,c=300/10000-300/10000-0/0;

Syntax: f1=freq@vol, f2=freq@vol, c=on1/off1-on2/off2-on3/off3; [...]
Note: freq: 0 - 4000Hz; vol: -30 - 0dBm

How to download XML Configuration?

- Click Management → Configuration →

How to Import Trusted CA certificate?

- Click Management → Trusted CA

Index	Issued TO	Issued By	Expiration	Delete
1				<input type="checkbox"/>
2				<input type="checkbox"/>
3				<input type="checkbox"/>
4				<input type="checkbox"/>
5				<input type="checkbox"/>
6				<input type="checkbox"/>
7				<input type="checkbox"/>
8				<input type="checkbox"/>
9				<input type="checkbox"/>
10				<input type="checkbox"/>

Import Trusted Certificate Files No file chosen

Only Accept Trusted Certificates On Off

Common Name Validation On Off

Trusted Certificates Default Certificates

Custom Certificates

All Certificates

How to Import Server CA certificate?

- Click Management→ Server CA

Issued TO	Issued By	Expiration	Delete
			Delete
Import Server Certificate Files	Choose File	No file chosen	
	Import Server Certificates		
Device Certificates	<input checked="" type="radio"/> Default Certificates		
	<input type="radio"/> Custom Certificates		
	SaveSet	Cancel	